

Good Luck!

**2015 European
Championship
Appaloosa Show**

2015 European Championship Appaloosa Show

4x ApHC approved
www.appaloosa.ch

8. - 11. October 2015
Horseacademy
Mooslargue
(France)



Swiss Appaloosa



Schmid Performance Horses

Pictures Jürgen Seyler | Artwork Sarah Simon



**ERAA Futurity
& Derby**

Pattern Book

European Championship Appaloosa

Jackpot Trail

Show Date: October 8th - 11th, 2015

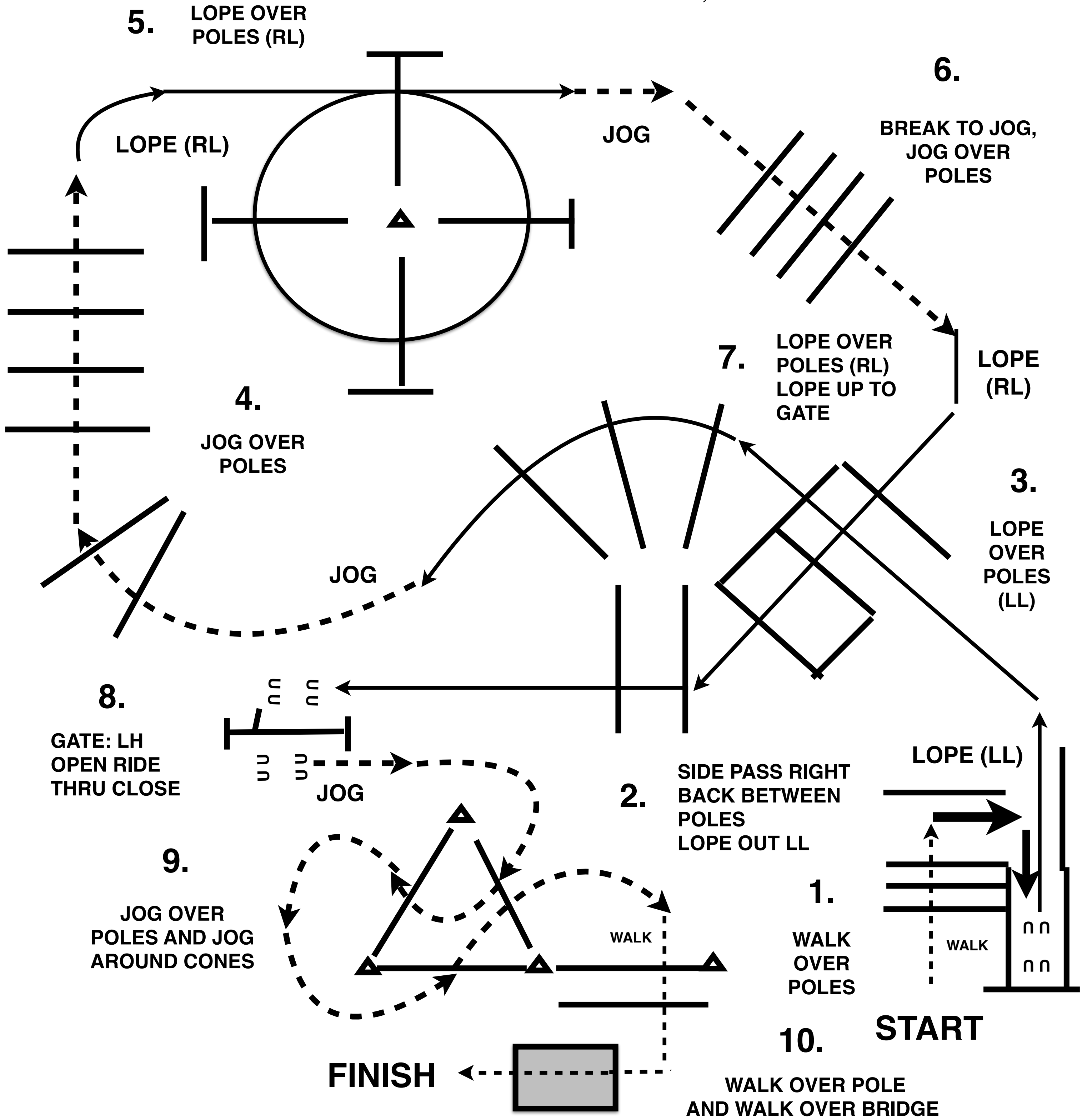

Copyright by Tim Kimura

Main Sponsor: Swissappaloosa

European Championship Appaloosa

N350 Non-Pro Trail

Show Date: October 8th - 11th, 2015

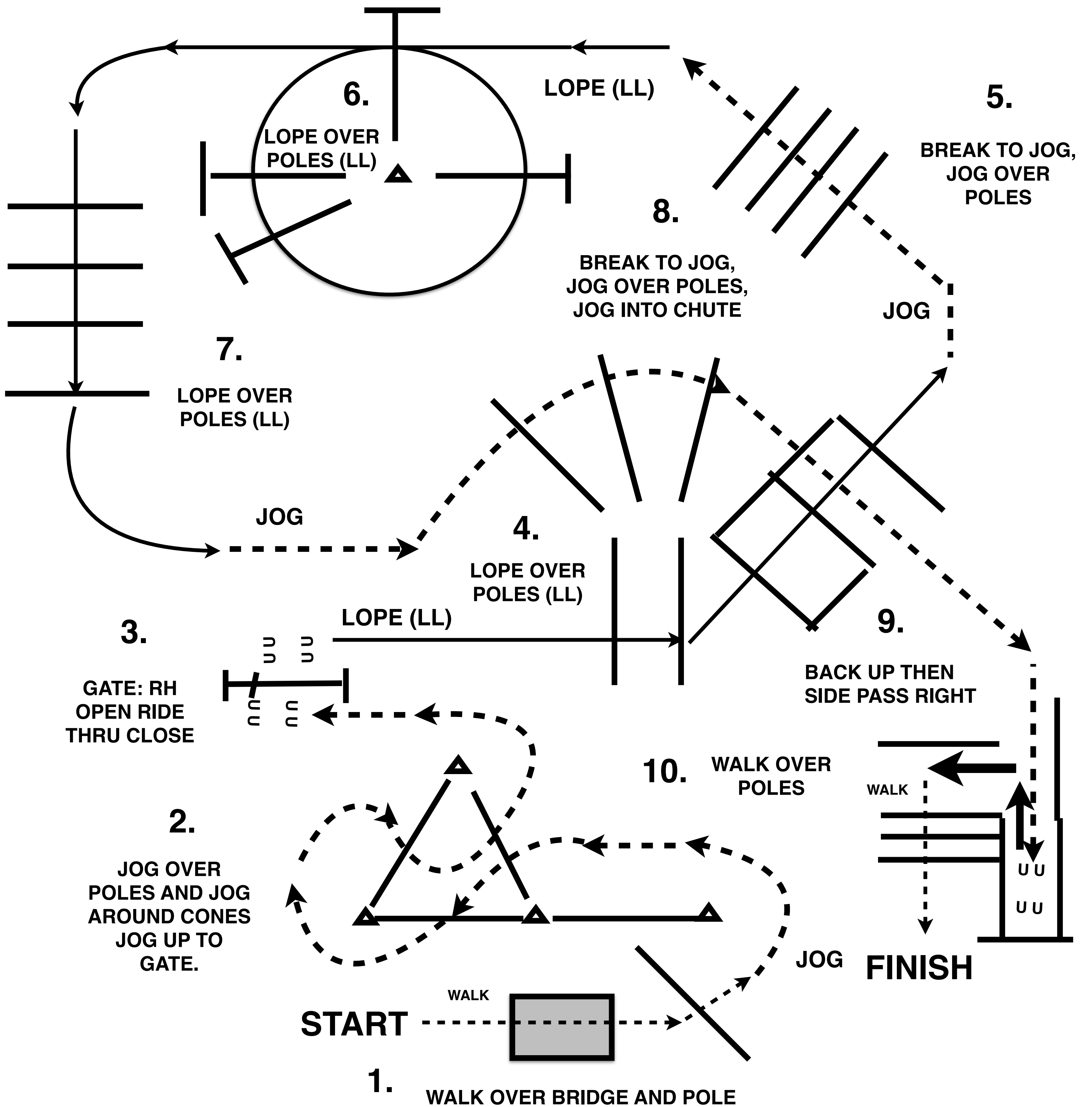

Copyright by Tim Kimura

Main Sponsor: Swissappaloosa

European Championship Appaloosa

Y140 Youth Western Horsemanship 18 & Under

Show Date: October 8th - 11th, 2015

w w w . H o r s e S h o w P a t t e r n s . c o m

w w w . H o r s e S h o w P a t t e r n s . c o m

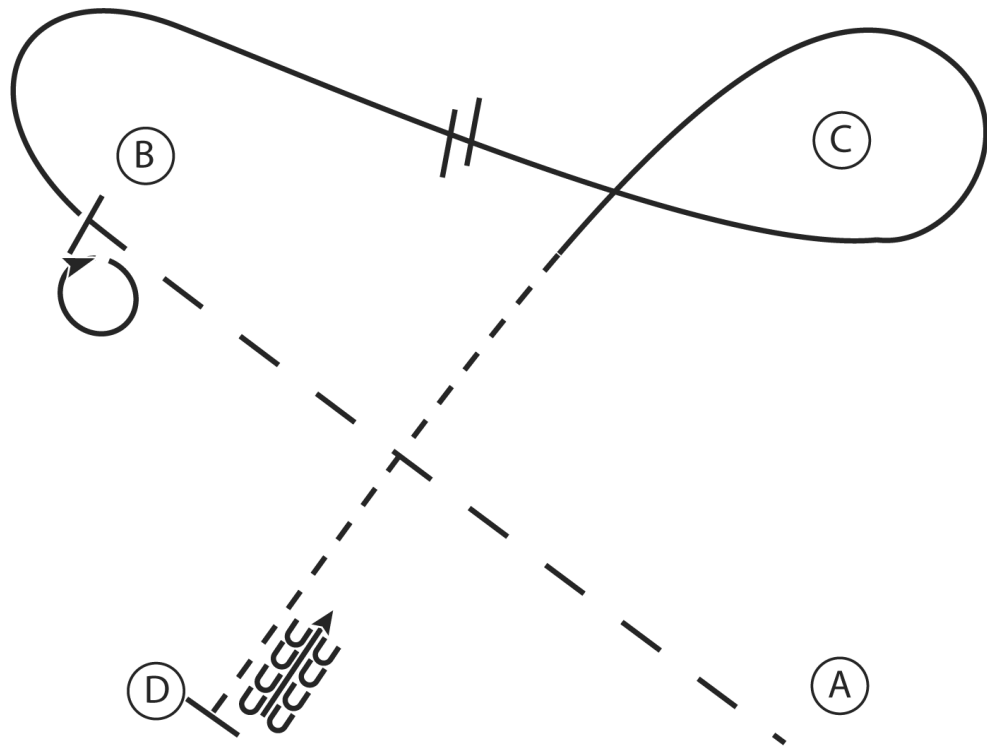

1. Extend the jog A to B
2. Stop at B and perform a 360 degree turn to the right
3. Lope on the right lead around B
4. Half way between B and C change leads and continue to and around C
5. Jog halfway between C and D
6. At D stop and back

Walk
Jog	-----
Extended Jog	-----
Lope	—————
Leg Yield	
Lead Change	—/—
Back	←←←←←
Marker	⊙
Sidepass	←-----→

[WH/2-27]

Pattern Provided by:

Main Sponsor: *Swissappaloosa*

European Championship Appaloosa

N110 Non-Pro Hunt Seat Equitation

Show Date: October 8th - 11th, 2015

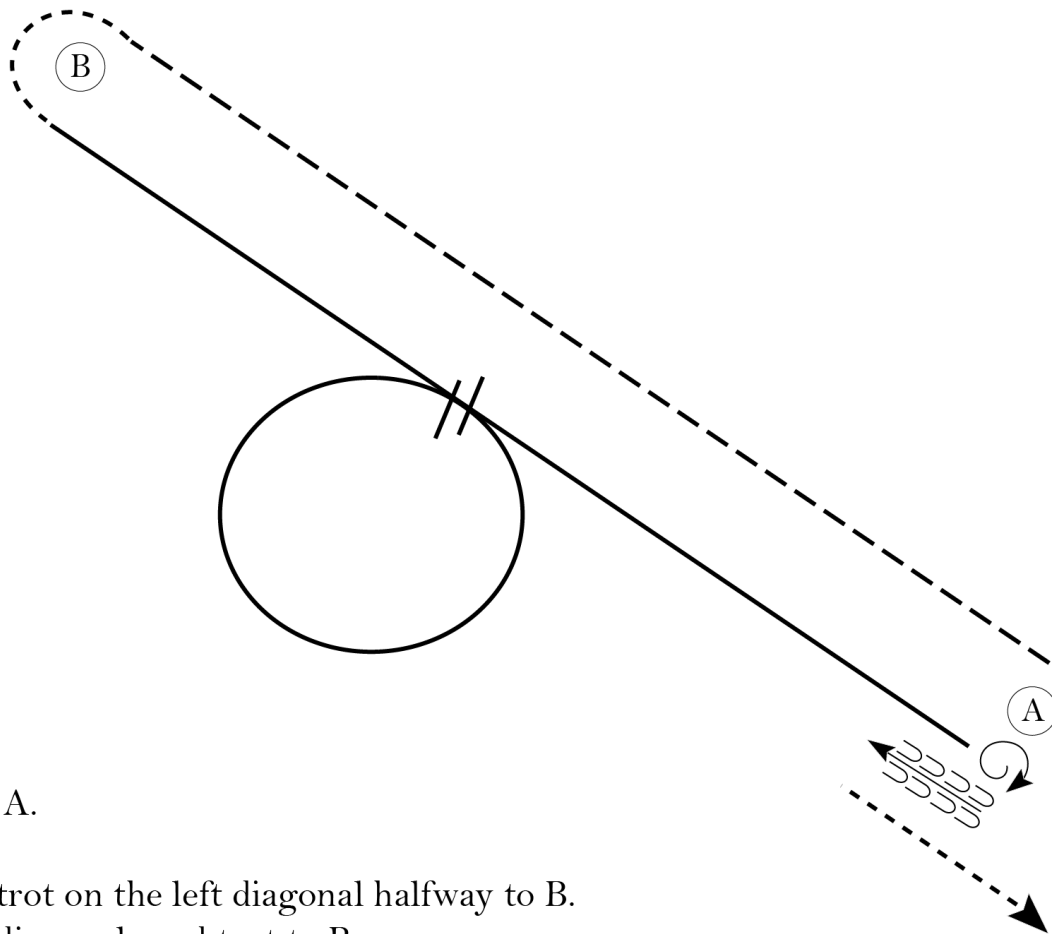

Be ready at A.

1. Posting trot on the left diagonal halfway to B.
2. Change diagonals and trot to B.
3. Break to the walk and walk around B.
4. Canter on the right lead halfway to A.
5. Continue to canter in a circle to the right.
6. Perform a simple lead change and canter to A.
7. Halt at A and perform a 360 degree turn on the forehand to the right.
8. Back approximately one horse length.

Pattern is over once you have backed. Walk off and follow the instructions of your ring steward.

Walk	-----
Trot	- - - - -
Extended Trot	— — — — —
Canter	—————
Leg Yield	
Lead Change	
Back	←←←←←
Marker	(B)
Sidepass	←←←←←
Hand Gallop	—————

[HSE/2-75]

Pattern Provided by:

Main Sponsor: *Swissappaloosa*

European Championship Appaloosa

O550 Open Ranch Horse Pleasure

Pattern 4

Show Date: October 8th - 11th, 2015

www.HorseShowPatterns.com

www.HorseShowPatterns.com

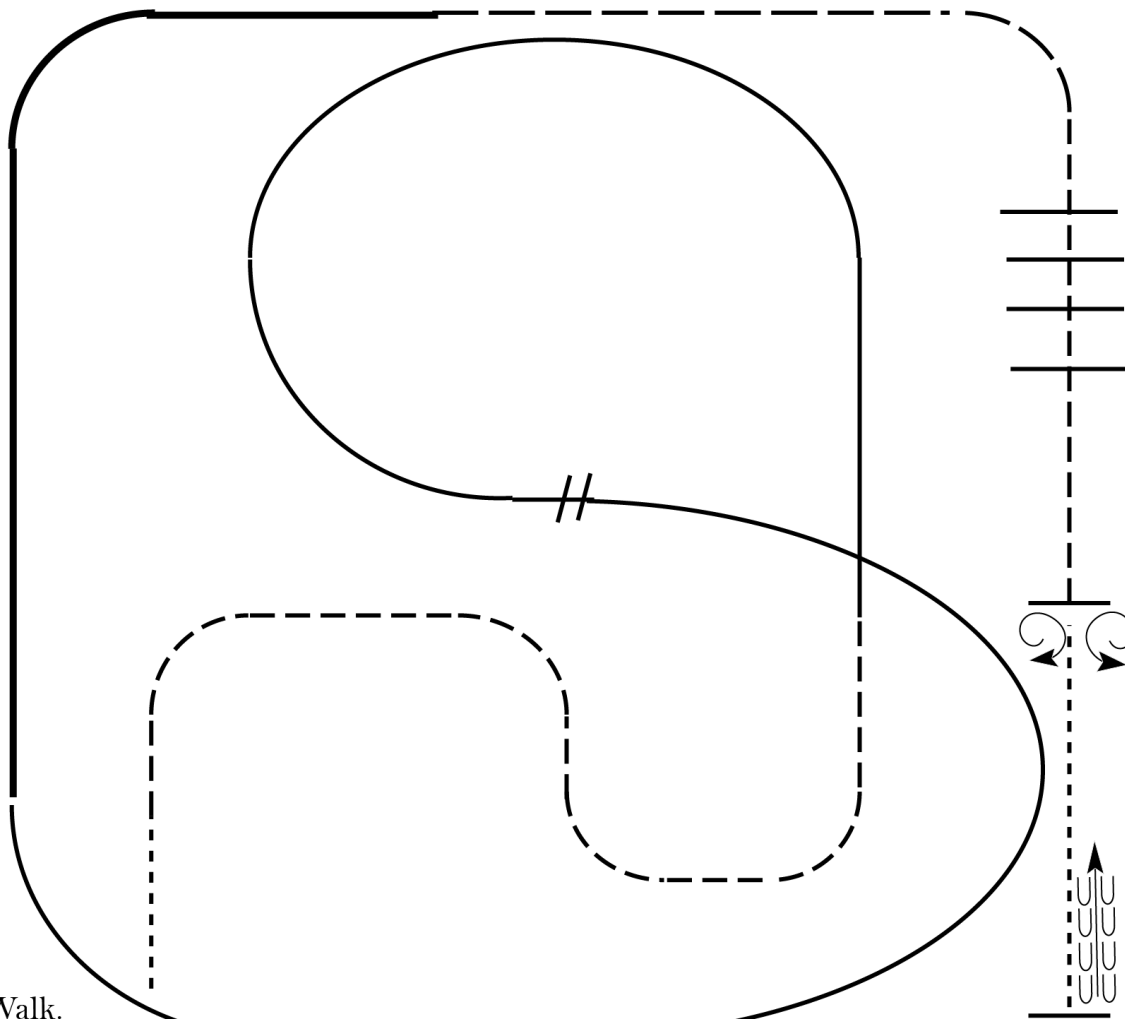

1. Walk.
2. Trot serpentine
3. Lope left lead around end of arena and then diagonally across arena.
4. Change leads (simple or flying) and
5. Lope on the right lead around end of the arena.
6. Extend lope on the straight away around corner to center of arena.
7. Extend trot around corner of arena
8. Collect to a trot
9. Trot over poles
10. Stop do a 360 turn each direction (either direction 1st)
11. Walk, stop and back.

Walk	-----
Jog	- - - - -
Extended Jog	-----
Lope	
Lead Change	///
Back	←←←←←
Marker	(B)

[RP/4]

Pattern Provided by:

Main Sponsor: *Swissappaloosa*

European Championship Appaloosa

Jackpot Reining

Pattern 10

Show Date: October 8th - 11th, 2015

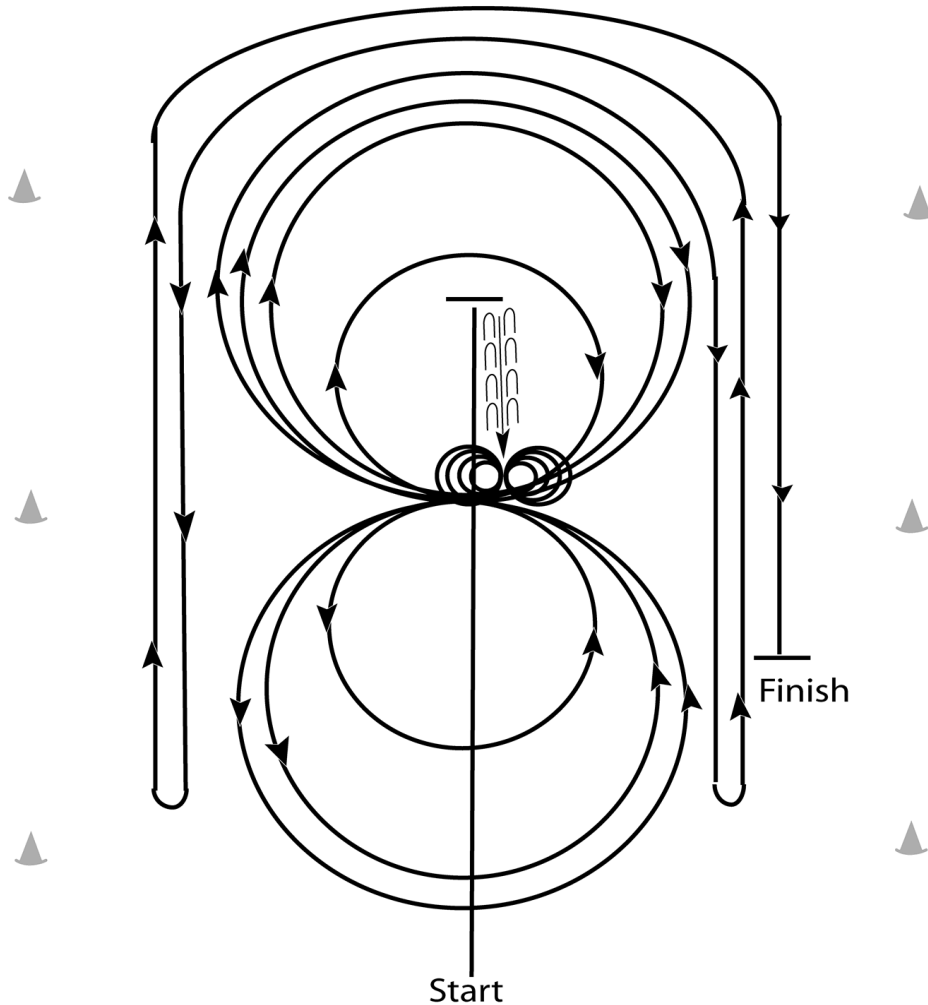

1. Run past the center marker and do a sliding stop. Back up to the center of the arena or at least ten feet (3m). Hesitate.
 2. Complete four spins to the right.
 3. Complete four and one-quarter spins to the left so that the horse is facing the left wall or fence. Hesitate.
 4. Beginning on the right lead, complete three circles to the right: the first two circles large and fast, the third circle small and slow. Change leads at the center of the arena.
 5. Complete three circles to the left: the first circle small and slow, the next two circles large and fast. Change leads at the center of the arena.
 6. Begin a large fast circle to the right but do not close this circle. Run down the right side of the arena past the center marker and do a left rollback at least twenty feet (6.09m) from the wall or fence – no hesitation.
 7. Continue back around the previous circle but do not close this circle. Run down the left side of the arena past the center and do a right rollback at least twenty feet (6.09m) from the wall or fence – no hesitation.
 8. Continue back around previous circle but do not close this circle. Run down the right side of the arena past the center marker and do a sliding stop at least twenty feet (6.09m) from the wall or fence. Hesitate to demonstrate completion of pattern.
- Rider may dismount and drop bridle to the designated judge.

[R/NRHAP-10]

Pattern Provided by:

Main Sponsor: *Swissappaloosa*

European Championship Appaloosa

N310 Non-Pro Showmanship at Halter

Show Date: October 8th - 11th, 2015

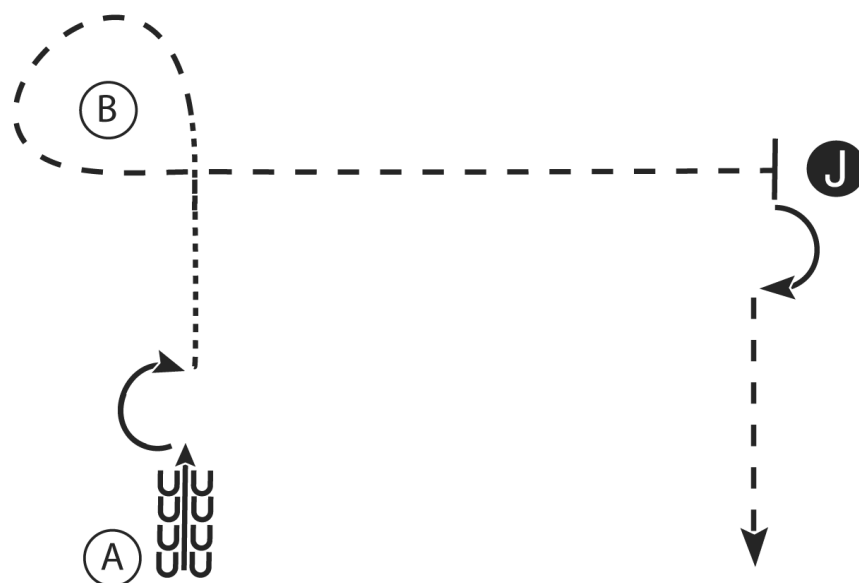

1. At A back 4 steps
2. Perform a 180 degree turn
3. Walk to B
4. At B trot around B and to the judge, set up for inspection
5. When dismissed perform a 90 degree turn and trot straight away from the judge

Walk - - - - -

Trot - - - - -

Back ← SSSSS

Marker (B)

Judge (J)

[S/2-1]

Pattern Provided by:

Main Sponsor: Swissappaloosa

European Championship Appaloosa

Y110 Youth Western Showmanship at Halter 18 & Under

Show Date: October 8th - 11th, 2015

w w w . H o r s e S h o w P a t t e r n s . c o m

w w w . H o r s e S h o w P a t t e r n s . c o m

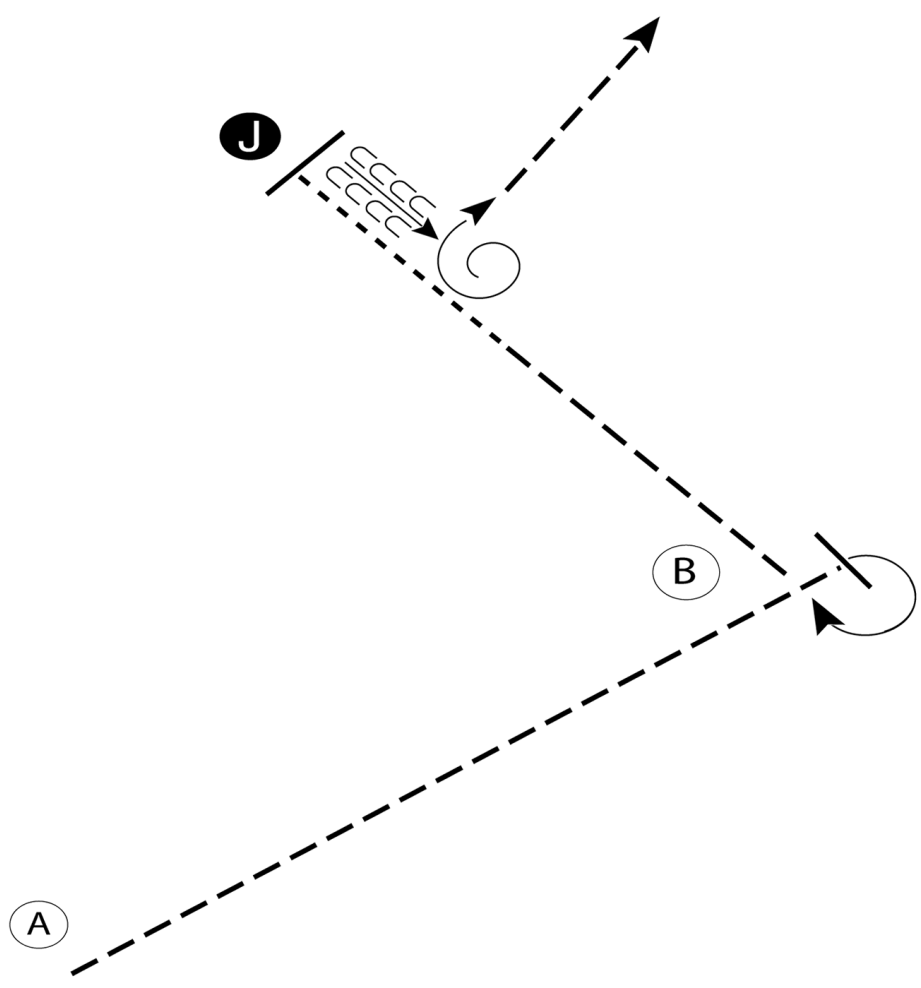

1. Begin at A. Trot past B and stop
2. Perform a 270 degree turn
3. Trot halfway to the Judge
4. Break to the walk and walk to the Judge
5. Stop and set up for inspection
6. When dismissed back one horse length
7. Perform a 450 degree turn and trot to the line-up

Walk	-----
Trot	- - - - -
Back	←
Marker	(B)
Judge	(J)

[S/2-27]

Pattern Provided by:

Main Sponsor: Swissappaloosa

European Championship Appaloosa

O360 Open Western Riding

Show Date: October 8th - 11th, 2015

Pattern 4

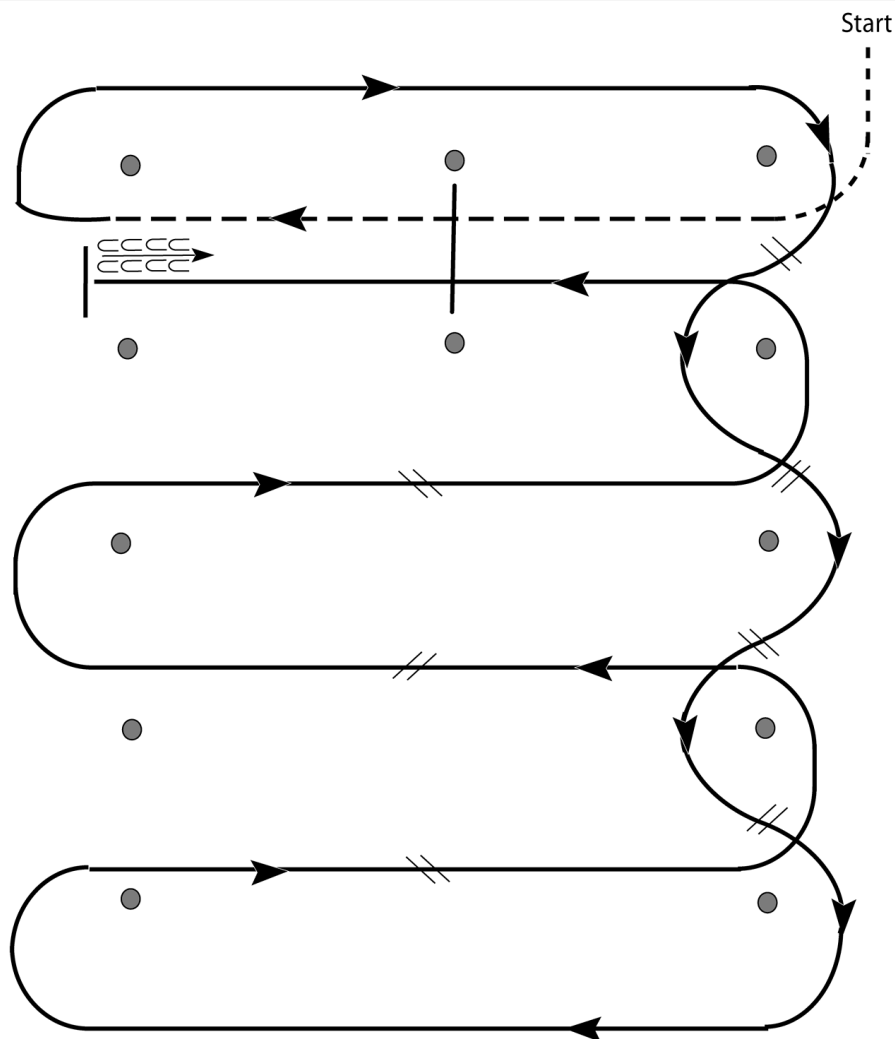

1. Walk, transition to jog, jog over log.
2. Transition to right.
3. First line change.
4. Second line change.
5. Third line change.
6. Fourth line change.
7. First crossing change.
8. Second crossing change.
9. Third crossing change.
10. Lope over log.
11. Lope, stop and back.

[WR/OP-4]

Pattern Provided by:

Main Sponsor: *Swissappaloosa*

w w w . H o r s e S h o w P a t t e r n s . c o m

w w w . H o r s e S h o w P a t t e r n s . c o m

European Championship Appaloosa

N370 Non-Pro Reining

Pattern 11

Show Date: October 8th - 11th, 2015

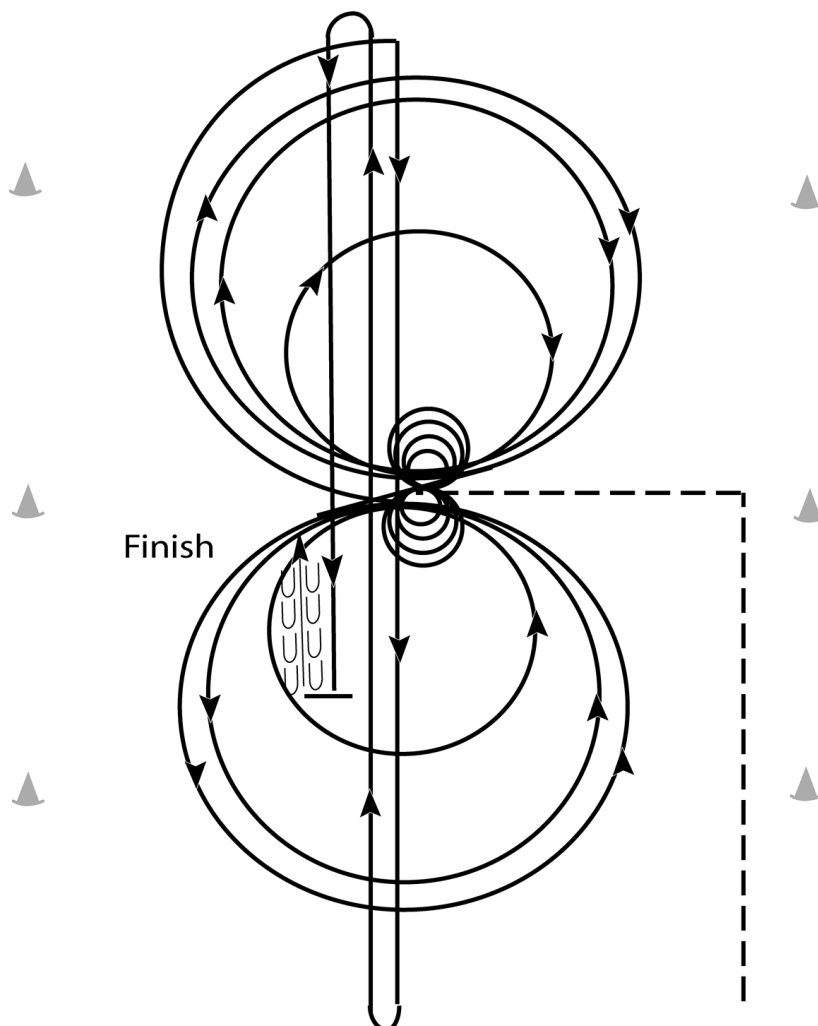

Horses must trot to the center of the arena. Horses must walk or stop prior to starting pattern. Begin at the center of the arena facing the left wall or fence.

1. Complete four spins to the left. Hesitate.
 2. Complete four spins to the right. Hesitate.
 3. Beginning on the right lead, complete three circles to the right; the first small and slow; the next two circles large and fast. Change leads at the center of the arena.
 4. Complete three circles to the left; the first small and slow; the next two circles large and fast. Change leads at the center of the arena.
 5. Begin a large circle to the right, but do not close this circle. Run down the center of the arena past the end marker and do a right rollback - no hesitation. C
 6. Run up the middle to the opposite end of the arena past the end marker and do a left rollback - no hesitation.
 7. Run past the center marker and do a sliding stop. Back up to the center of the arena or at least 10 feet (3m). Hesitate to demonstrate completion of pattern.
- Rider must dismount and drop bridle to the designated judge.

[R/NRHAP-11]

Pattern Provided by:

Main Sponsor: *Swissappaloosa*

European Championship Appaloosa

O385 Open Green Trail

Show Date: October 8th - 11th, 2015

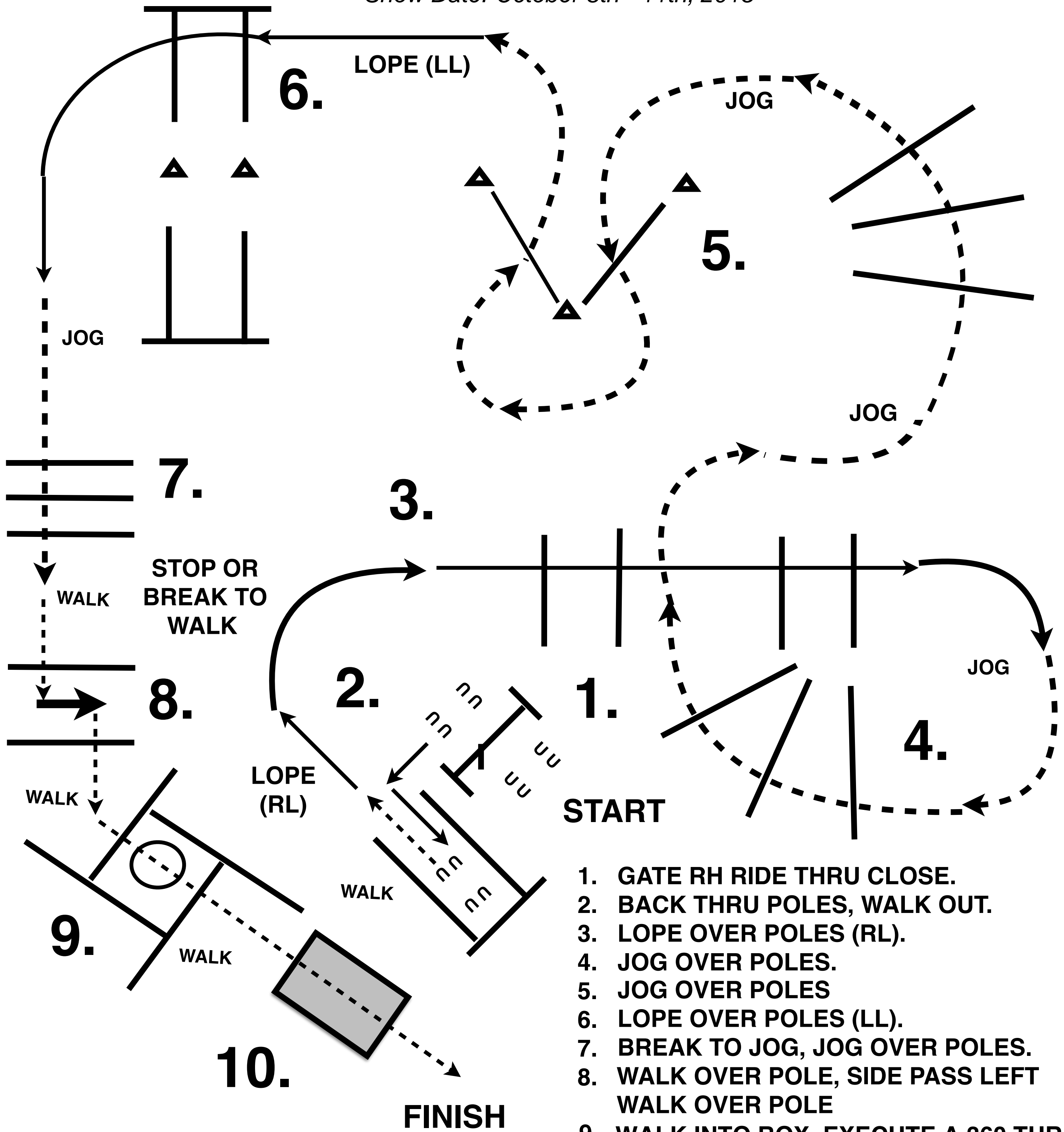

1. GATE RH RIDE THRU CLOSE.
2. BACK THRU POLES, WALK OUT.
3. LOPE OVER POLES (RL).
4. JOG OVER POLES.
5. JOG OVER POLES
6. LOPE OVER POLES (LL).
7. BREAK TO JOG, JOG OVER POLES.
8. WALK OVER POLE, SIDE PASS LEFT
WALK OVER POLE
9. WALK INTO BOX, EXECUTE A 360 TURN
EITHER WAY, WALK OUT BOX.
10. WALK OVER BRIDGE

Copyright by Tim Kimura

Main Sponsor: Swissappaloosa

European Championship Appaloosa

O382 Senior Trail

Show Date: October 8th - 11th, 2015

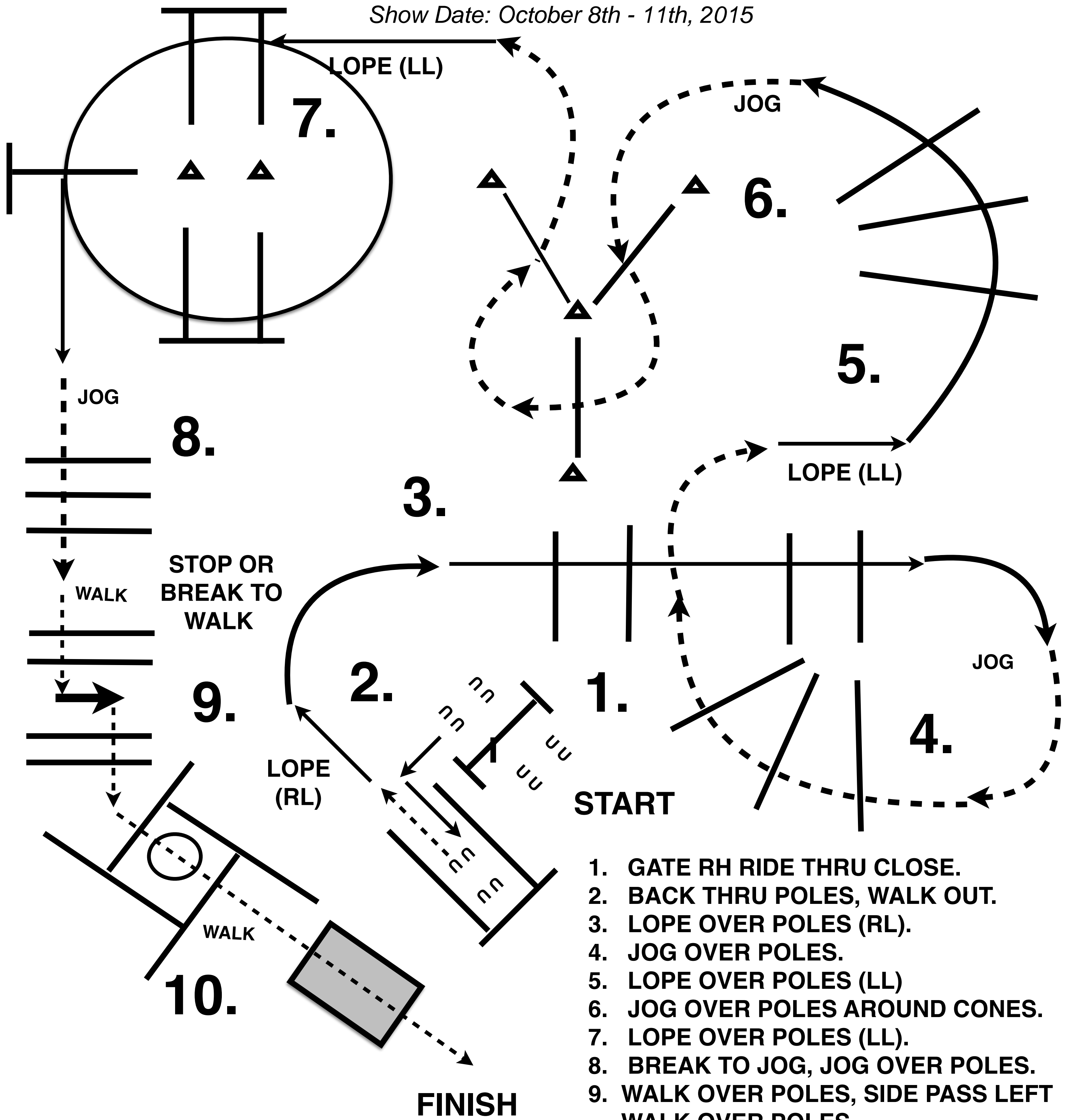

1. GATE RH RIDE THRU CLOSE.
2. BACK THRU POLES, WALK OUT.
3. LOPE OVER POLES (RL).
4. JOG OVER POLES.
5. LOPE OVER POLES (LL)
6. JOG OVER POLES AROUND CONES.
7. LOPE OVER POLES (LL).
8. BREAK TO JOG, JOG OVER POLES.
9. WALK OVER POLES, SIDE PASS LEFT WALK OVER POLES
10. WALK INTO BOX, EXECUTE A 360 TURN EITHER WAY, WALK OUT OF BOX AND OVER BRIDGE.

Copyright by Tim Kimura

Main Sponsor: Swissappaloosa

European Championship Appaloosa

Y150 Youth Hunt Seat Equitation 18 & Under

Show Date: October 8th - 11th, 2015

w w w . H o r s e S h o w P a t t e r n s . c o m

w w w . H o r s e S h o w P a t t e r n s . c o m

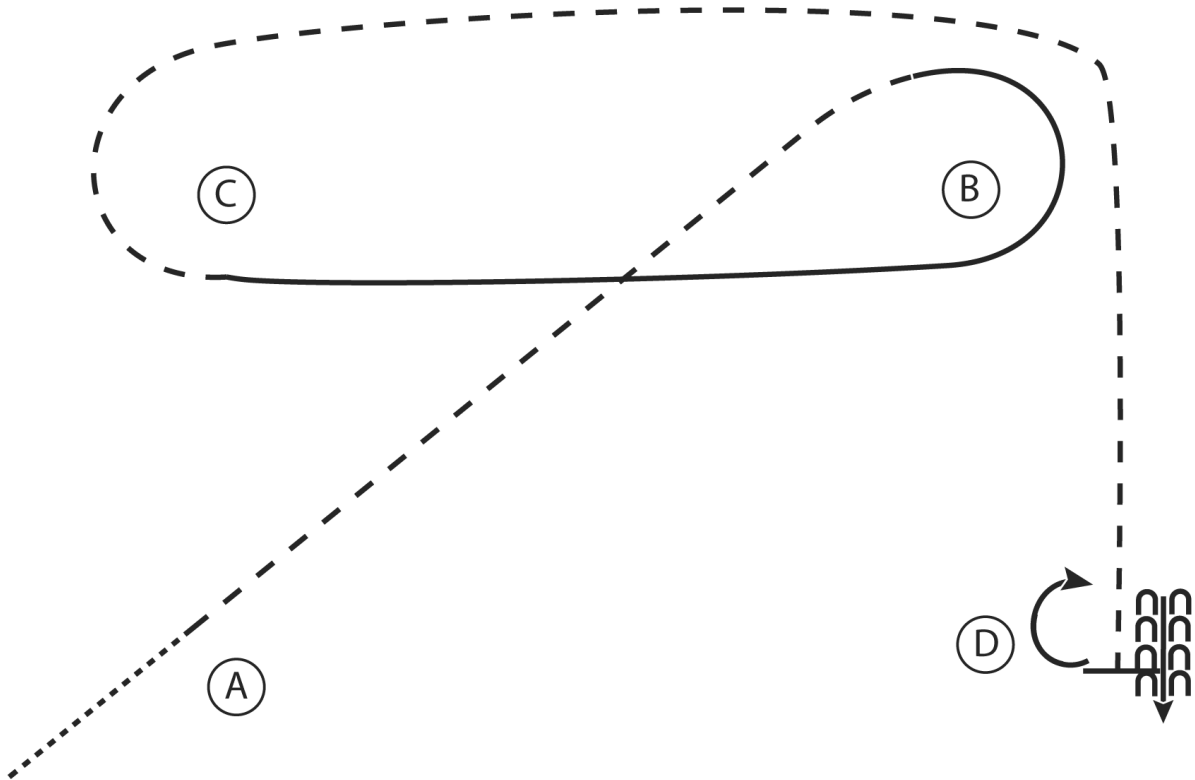

1. Walk to A
2. Sitting trot to B
3. At B canter on the right lead around B to C
4. At C posting trot around C and B to D
5. At D stop and perform a 180 degree turn to the right on the hindquarters
6. Back 4 steps

Walk
Trot	-----
Extended Trot	-----
Canter	—————
Leg Yield	
Lead Change	///
Back	←←←←
Marker	(B)
Sidepass	←-----←

[HSE/2-10]

Pattern Provided by:

Main Sponsor: Swissappaloosa

European Championship Appaloosa

N340 Non-Pro Western Riding

Show Date: October 8th - 11th, 2015

Pattern 3

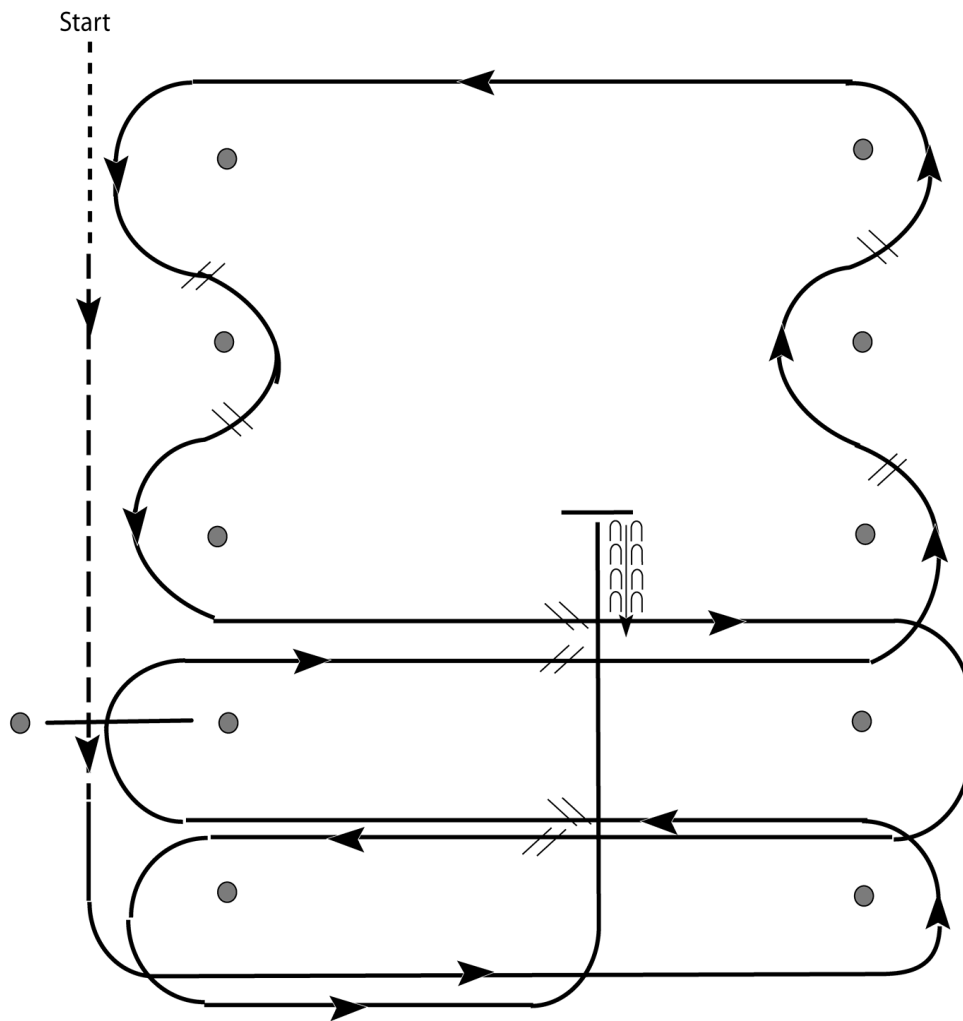

1. Walk, transition to jog, jog over log.
2. Transition to left.
3. First crossing change.
4. Lope over log.
5. Second crossing change.
6. First line change.
7. Second line change.
8. Third line change.
9. Fourth line change.
10. Third crossing change.
11. Fourth crossing change.
12. Lope up the center, stop and back.

[WR/OP-3]

Pattern Provided by:

Main Sponsor: *Swissappaloosa*

www.HorseShowPatterns.com

www.HorseShowPatterns.com

European Championship Appaloosa

O341 Open Junior Reining

Show Date: October 8th - 11th, 2015

Pattern 6

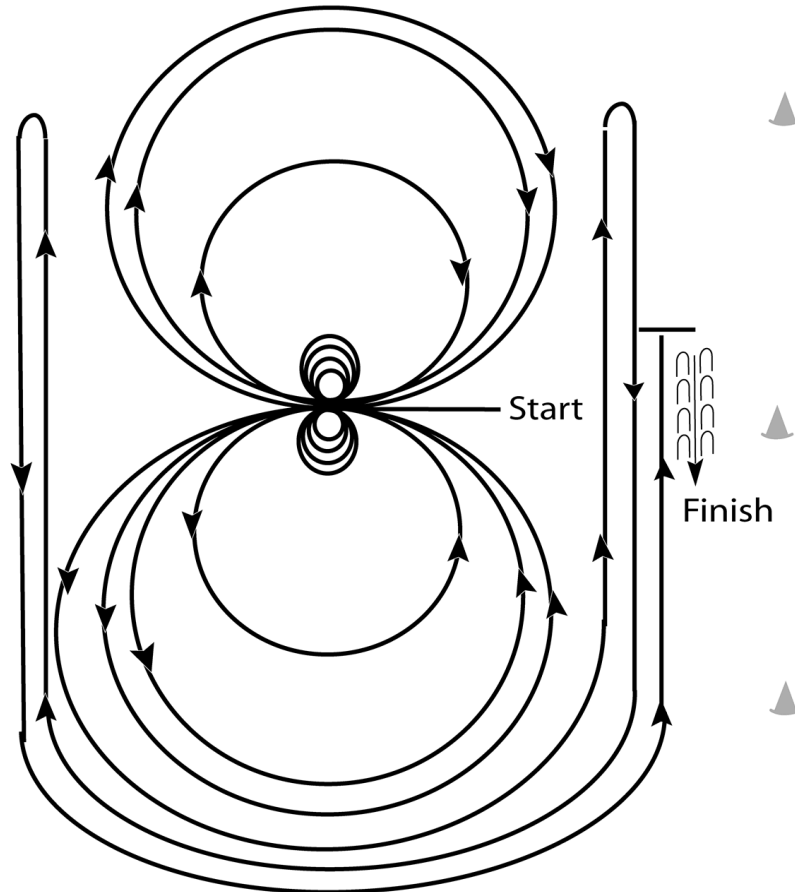

Horses may walk or trot to the center of the arena. Beginning at the center of the arena facing the left wall or fence.

1. Complete four spins to the right.
 2. Complete four spins to the left. Hesitate.
 3. Beginning on the left lead, complete three circles to the left: the first two circles large and fast; the third circle small and slow. Change leads at the center of the arena.
 4. Complete three circles to the right: the first two circles large and fast; the third circle small and slow. Change leads at the center of the arena.
 5. Begin a large, fast circle to the left but do not close this circle. Run up the right side of the arena past the center marker and do a right rollback at least twenty feet (6.09m) from the wall or fence – no hesitation.
 6. Continue back around previous circle but do not close this circle. Run up the left side of the arena past the center marker and do a left rollback at least twenty feet (6.09m) from the wall or fence – no hesitation.
 7. Continue back around previous circle but do not close this circle. Run up the right side of the arena past the center marker and do a sliding stop at least twenty feet (6.09m) from the wall or fence. Back up at least ten feet (3m). Hesitate to demonstrate the completion of the pattern.
- Rider may dismount and drop bridle to the designated judge.

[R/NRHAP-6]

Pattern Provided by:

Main Sponsor: Swissappaloosa

European Championship Appaloosa

Y120 English Showmanship 18 & Under

Show Date: October 8th - 11th, 2015

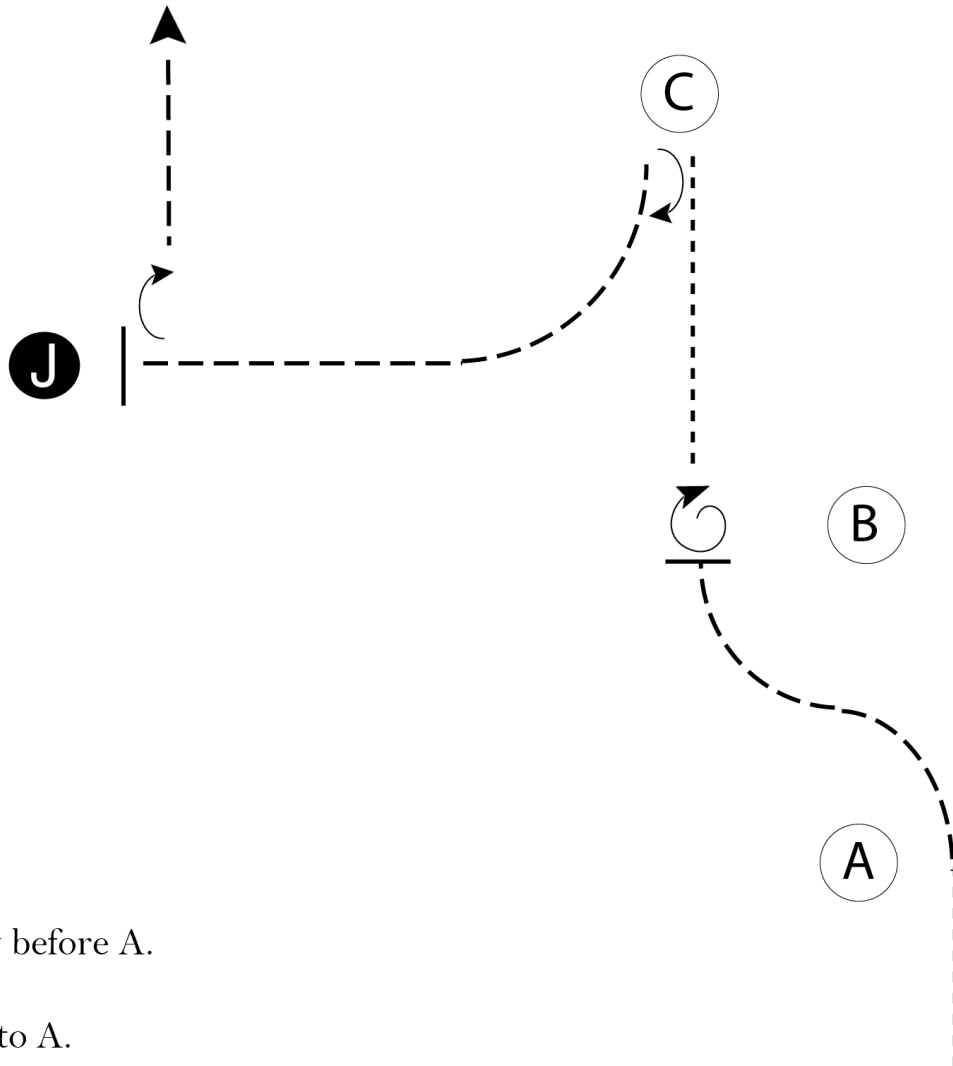

Be ready before A.

1. Walk to A.
2. Trot to B as shown.
3. Stop at B and perform a full turn.
4. Walk to C.
5. Perform a 180 degree turn and trot to Judge.
6. Perform a 1/4 turn and set up for inspection.
7. When dismissed, exit at a trot.

Follow the instructions of your ring steward.

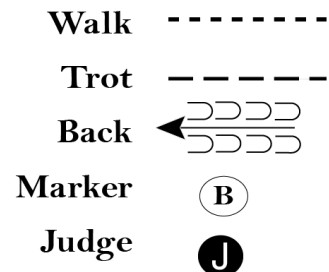

[S/2-91]

Pattern Provided by:

Main Sponsor: *Swissappaloosa*

European Championship Appaloosa

N320 Non-Pro Western Horsemanship

Show Date: October 8th - 11th, 2015

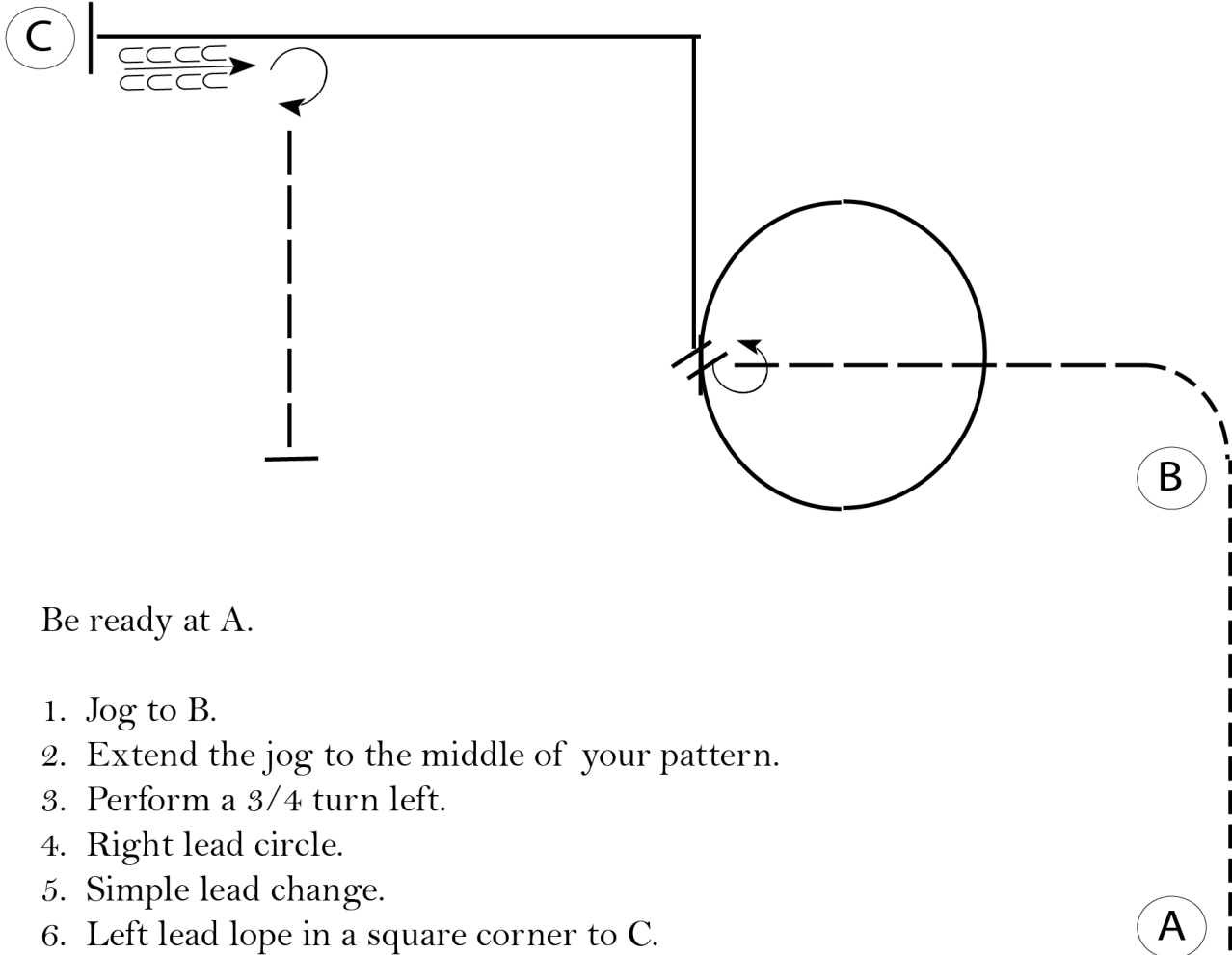

Be ready at A.

1. Jog to B.
2. Extend the jog to the middle of your pattern.
3. Perform a 3/4 turn left.
4. Right lead circle.
5. Simple lead change.
6. Left lead lope in a square corner to C.
7. Stop and back.
8. Perform a 3/4 turn right.
9. Extend the jog until you are in line with B. Stop.

Walk	-----
Jog	- - - - -
Extended Jog	— — — — —
Lope	— — — — —
Lead Change	— — — — —
Back	← — — — —
Marker	ⓐ

[WH/2-111]

Pattern Provided by:

Main Sponsor: *Swissappaloosa*

European Championship Appaloosa

Y804 Youth Ranch Horse Pleasure

Pattern 1





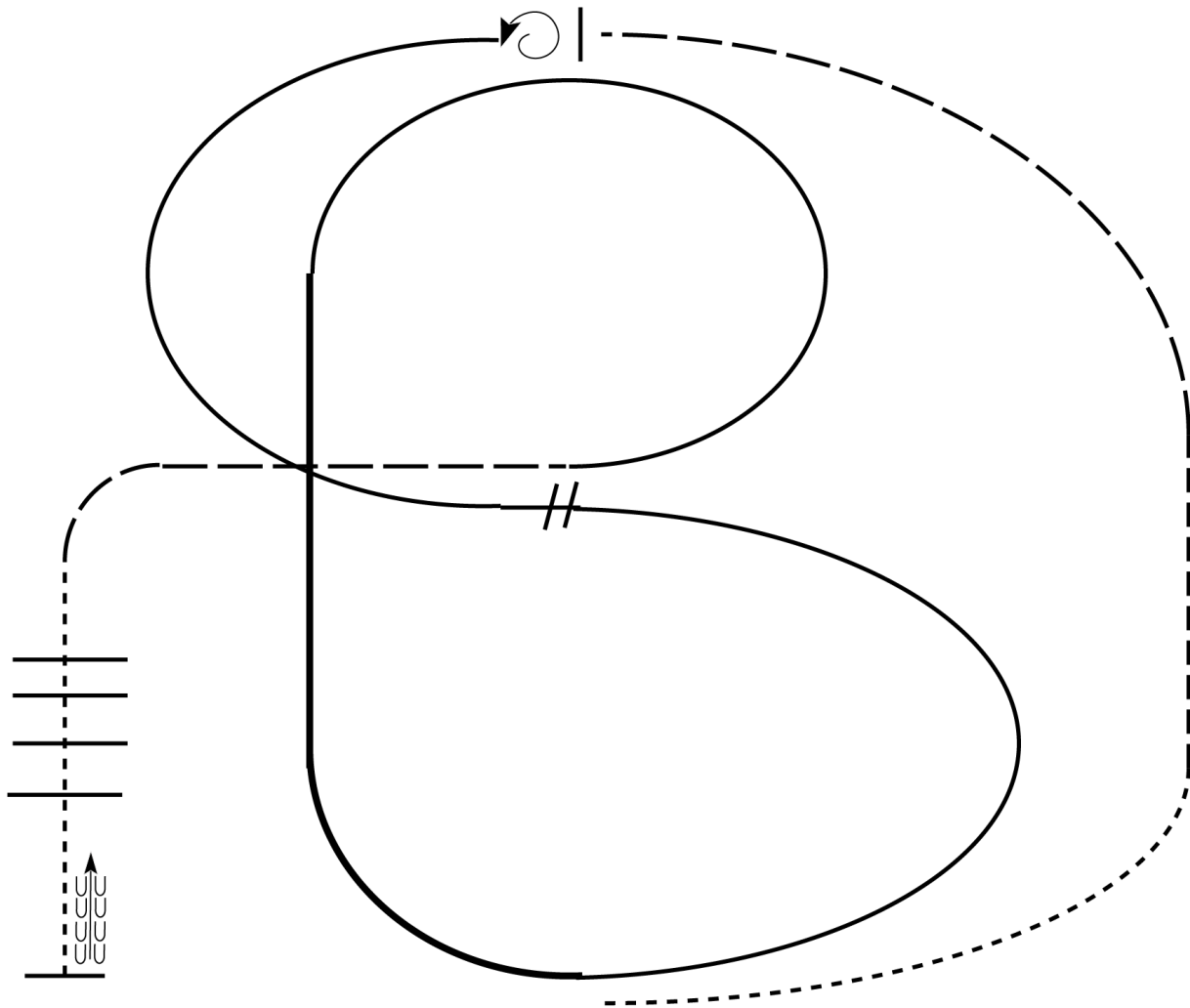

Show Date: October 8th - 11th, 2015

w w w . H o r s e S h o w P a t t e r n s . c o m

w w w . H o r s e S h o w P a t t e r n s . c o m



1. Walk
2. Trot
3. Extend the trot, at the top of the arena, stop
4. 360 degree turn to the left
5. Left lead 1/2 circle, lope to the center
6. Change leads (simple or flying)
7. Right lead 1/2 circle
8. Extended lope up the long side of arena (right lead)
9. Collect back to a lope around the top of the arena and back to center
10. Break down to an extended trot
11. Walk over poles.
12. Stop and back

- Walk 
- Jog 
- Extended Jog 
- Lope 
- Lead Change 
- Back 
- Marker 

[RP/1]

Pattern Provided by:

Main Sponsor: *Swissappaloosa*

European Championship Appaloosa

Y190 Youth Reining 18 & Under

Pattern 4

Show Date: October 8th - 11th, 2015

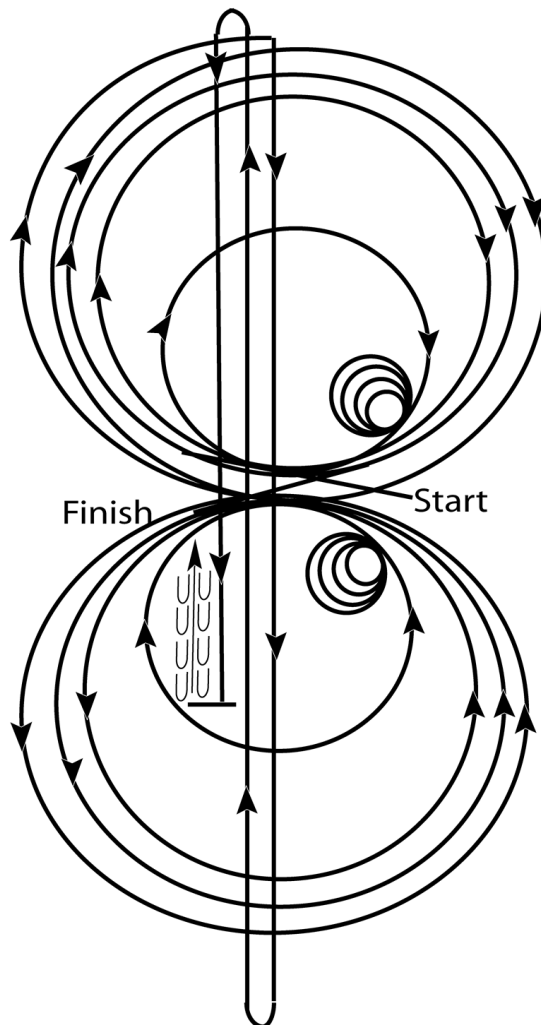

Horses may walk or trot to the center of the arena. Begin at the center of the arena facing the left wall or fence.

1. Beginning on the right lead, complete three circles to the right; the first two circles large and fast; the third circle small and slow. Stop at the center of the arena.
 2. Complete four spins to the right. Hesitate.
 3. Beginning on the left lead, complete three circles to the left; the first two circles large and fast; the third circle small and slow. Stop at the center of the arena.
 4. Complete four spins to the left. Hesitate.
 5. Beginning on the right lead, run a large first circle to the right, change leads at the center of the arena, run a large fast circle to the left, and change leads at the center of the arena.
 6. Continue around previous circle to the right. At the top of the circle, run down the middle to the far end of the arena past the end marker and do a right rollback - no hesitation.
 7. Run up the middle to the opposite end of the arena past the end marker and do a left rollback - no hesitation.
 8. Run past the center marker and do a sliding stop. Back up to the center of the arena or at least 10 feet (3m). Hesitate to demonstrate completion of the pattern.
- Rider may dismount and drop bridle to the designated judge.

[R/NRHAP-4]

Pattern Provided by:

Main Sponsor: Swissappaloosa

European Championship Appaloosa

ERAA Futurity

Pattern 5

Show Date: October 8th - 11th, 2015

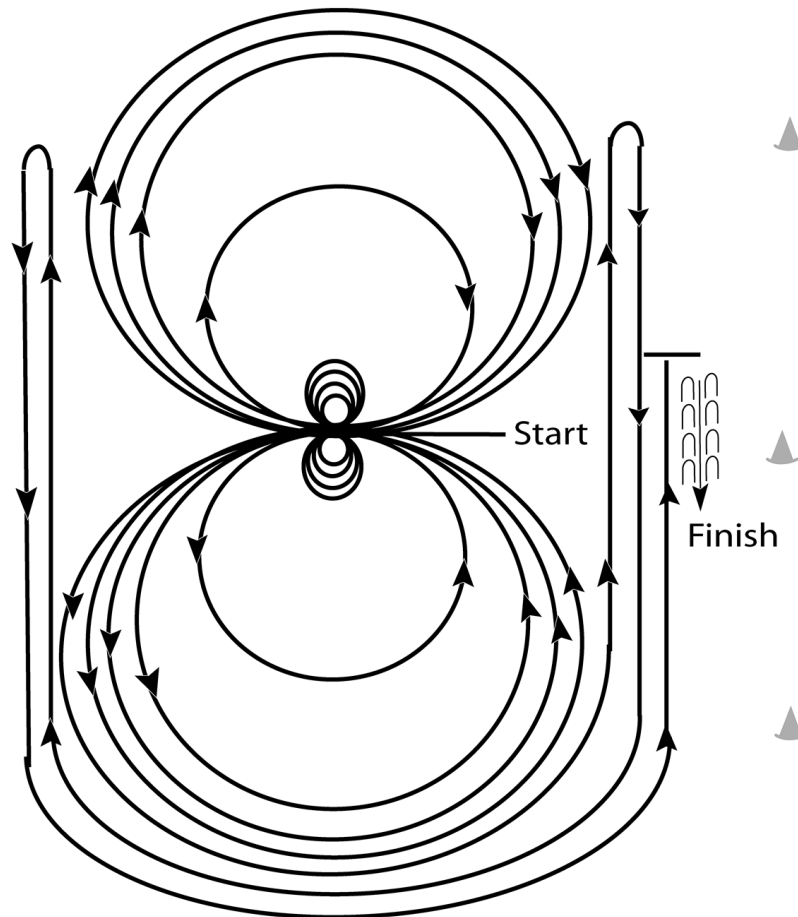

Horses may walk or trot to the center of the arena. Beginning at the center of the arena facing the left wall or fence.

1. Beginning on the left lead, complete three circles to the left: the first two circles large and fast; the third circle small and slow. Stop at the center of the arena.
 2. Complete four spins to the left. Hesitate.
 3. Beginning on the right lead, complete three circles to the right: the first two circles large and fast; the third circle small and slow. Stop at the center of the arena.
 4. Complete four spins to the right. Hesitate.
 5. Beginning on the left lead, run a large fast circle to the left, change leads at the center of the arena, run a large fast circle to the right, and change leads at the center of the arena.
 6. Continue around previous circle to the left but do not close this circle. Run up the right side of the arena past the center marker and do a right rollback at least twenty feet (6.09m) from the wall or fence – no hesitation.
 7. Continue around previous circle but do not close this circle. Run up the left side of the arena past the center marker and do a left rollback at least twenty feet (6.09m) from the wall or fence – no hesitation.
 8. Continue back around previous circle but do not close this circle. Run up the right side of the arena past the center marker and do a sliding stop at least twenty feet (6.09m) from the wall or fence. Back up at least ten feet (3m). Hesitate to demonstrate completion of the pattern.
- Rider may dismount and drop bridle to the designated judge.

[R/NRHAP-5]

Pattern Provided by:

Main Sponsor: *Swissappaloosa*

European Championship Appaloosa

ERAA Derby

Pattern 10

Show Date: October 8th - 11th, 2015

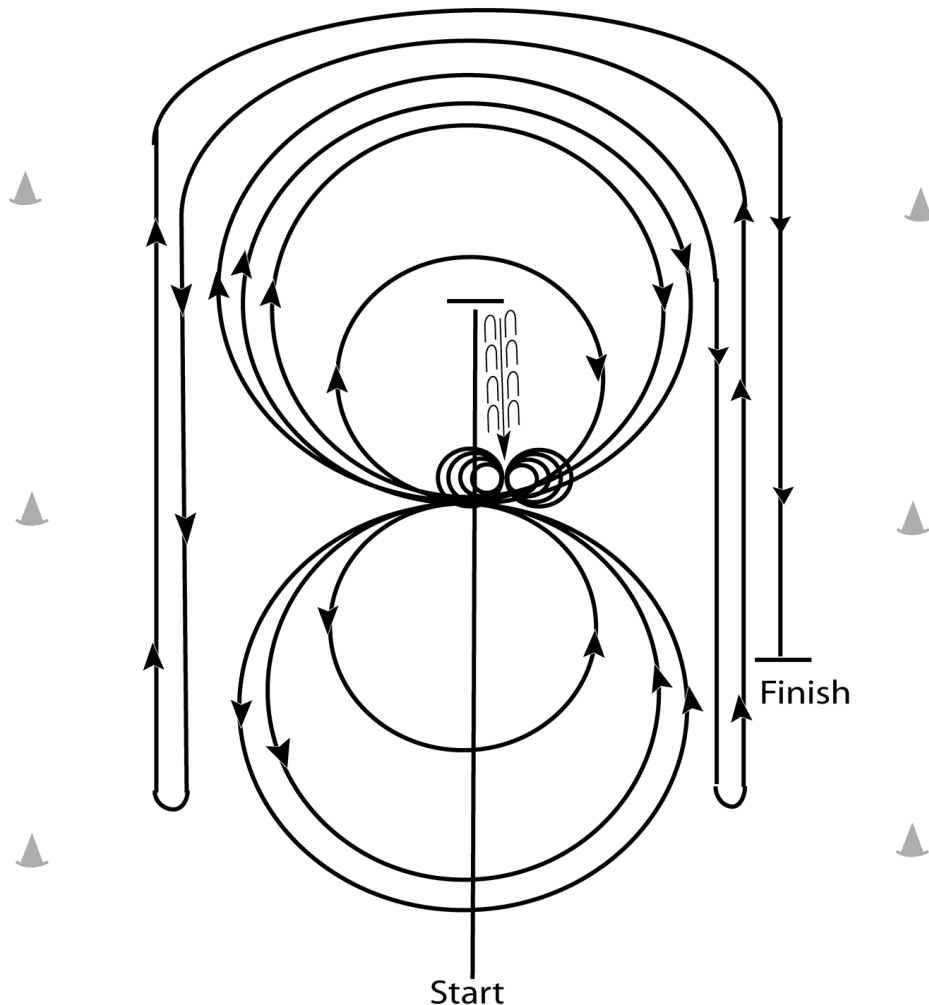

1. Run past the center marker and do a sliding stop. Back up to the center of the arena or at least ten feet (3m). Hesitate.
 2. Complete four spins to the right.
 3. Complete four and one-quarter spins to the left so that the horse is facing the left wall or fence. Hesitate.
 4. Beginning on the right lead, complete three circles to the right: the first two circles large and fast, the third circle small and slow. Change leads at the center of the arena.
 5. Complete three circles to the left: the first circle small and slow, the next two circles large and fast. Change leads at the center of the arena.
 6. Begin a large fast circle to the right but do not close this circle. Run down the right side of the arena past the center marker and do a left rollback at least twenty feet (6.09m) from the wall or fence – no hesitation.
 7. Continue back around the previous circle but do not close this circle. Run down the left side of the arena past the center and do a right rollback at least twenty feet (6.09m) from the wall or fence – no hesitation.
 8. Continue back around previous circle but do not close this circle. Run down the right side of the arena past the center marker and do a sliding stop at least twenty feet (6.09m) from the wall or fence. Hesitate to demonstrate completion of pattern.
- Rider may dismount and drop bridle to the designated judge.

[R/NRHAP-10]

Pattern Provided by:

Main Sponsor: *Swissappaloosa*

European Championship Appaloosa

O160 Open Working Cowhorse all Ages

Pattern 1

Show Date: October 8th - 11th, 2015

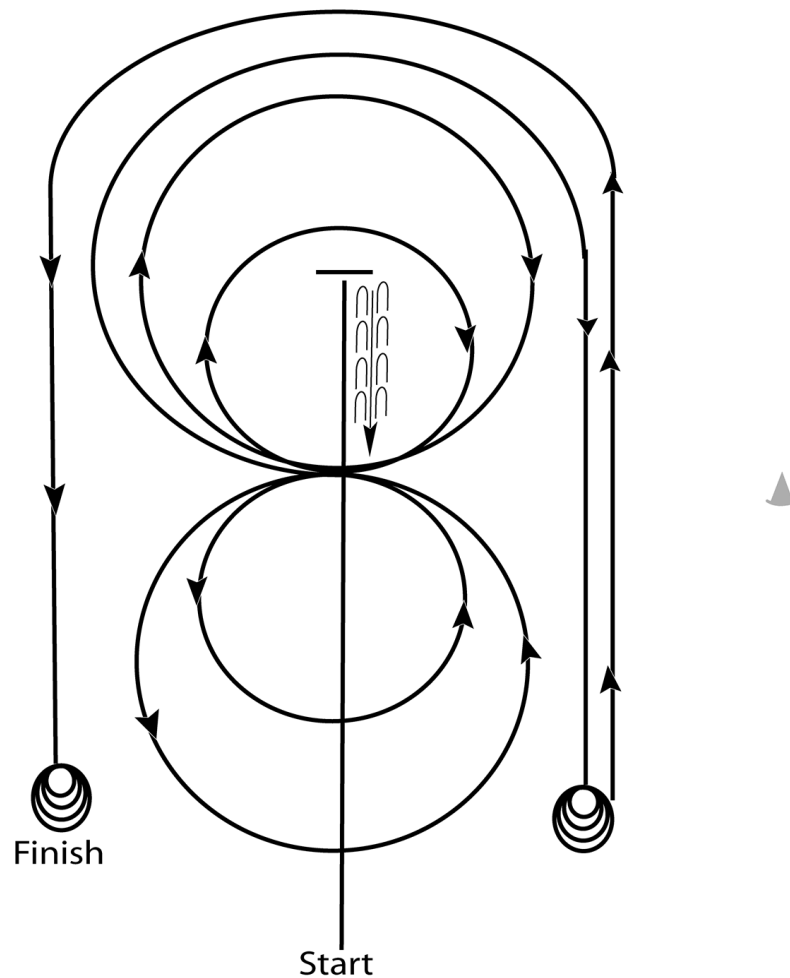

Pattern 1

1. Start at end of arena. Run down middle past center marker to a sliding stop.
2. Back at least 10 feet to center. 1/4 turn left.
3. Pickup right lead, big fast circle, small slow circle.
4. Change leads to left, big fast circle, small slow circle.
5. Change leads to right, do not close this circle.
6. Run around end of arena and down the side (approximately 20 feet from fence) past center marker and come to a sliding stop.
7. Complete 3 1/2 turns to the right.
8. Continue back down side and end of arena to other side (approximately 20 feet from fence) go past center marker and come to a sliding stop.
9. Complete 3 1/2 turns to the left.
10. Hesitate to complete pattern.

[NRCHAWC/1]

Pattern Provided by:

Main Sponsor: *Swissappaloosa*

European Championship Appaloosa

O342 Open Senior Reining

Show Date: October 8th - 11th, 2015

Pattern 8

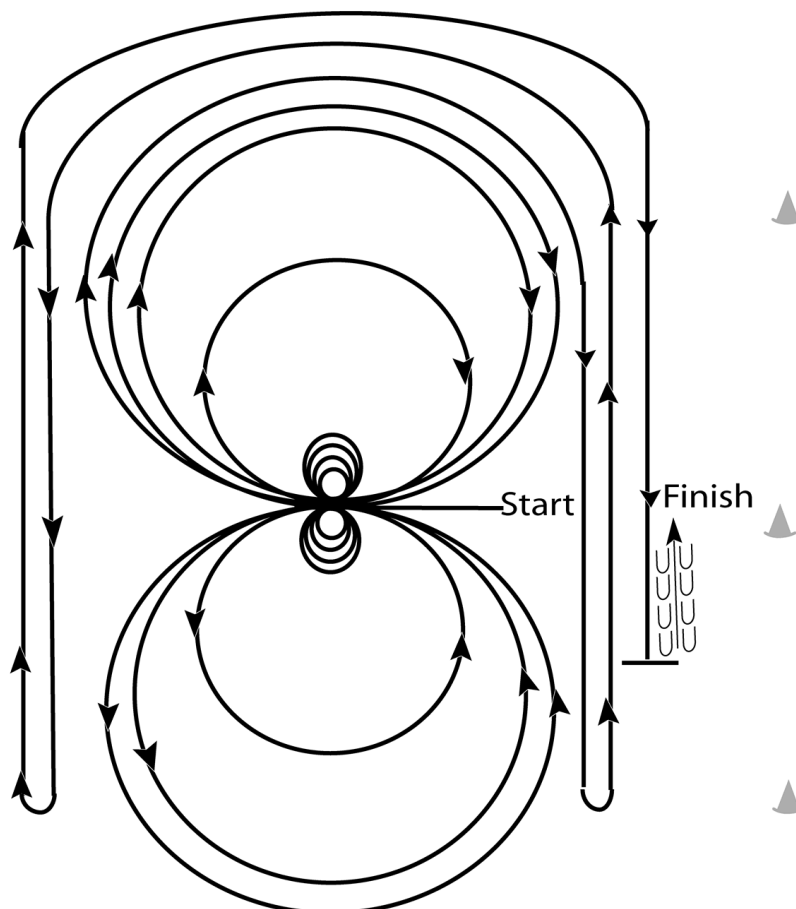

Horses may walk or trot to the center of the arena. Beginning at the center of the arena facing the left wall or fence.

1. Complete four spins to the left.
 2. Complete four spins to the right. Hesitate.
 3. Beginning on the right lead, complete three circles to the right: the first circle large and fast; the second circle small and slow; the third circle large and fast. Change leads at the center of the arena.
 4. Complete three circles to the left: the first circle large and fast; the second circle small and slow; the third circle large and fast. Change leads at the center of the arena.
 5. Begin a large fast circle to the right but do not close this circle. Run straight down the right side of the arena past the center marker and do a left rollback at least twenty feet (6.09m) from the wall or fence – no hesitation.
 6. Continue back around the previous circle but do not close this circle. Run down the left side of the arena past the center marker and do a right rollback at least twenty feet (6.09m) from the wall or fence – no hesitation.
 7. Continue back around the previous circle but do not close this circle. Run down the right side of the arena past the center marker and do a sliding stop at least twenty feet (6.09m) from the wall or fence. Back up at least ten feet (3m). Hesitate to demonstrate completion of the pattern.
- Rider may dismount and drop bridle to the designated judge.

[R/NRHAP-8]

Pattern Provided by:

Main Sponsor: *Swissappaloosa*

European Championship Appaloosa

O381 Open Junior Trail / Y290 Youth Trail 18 & Under

Show Date: October 8th - 11th, 2015

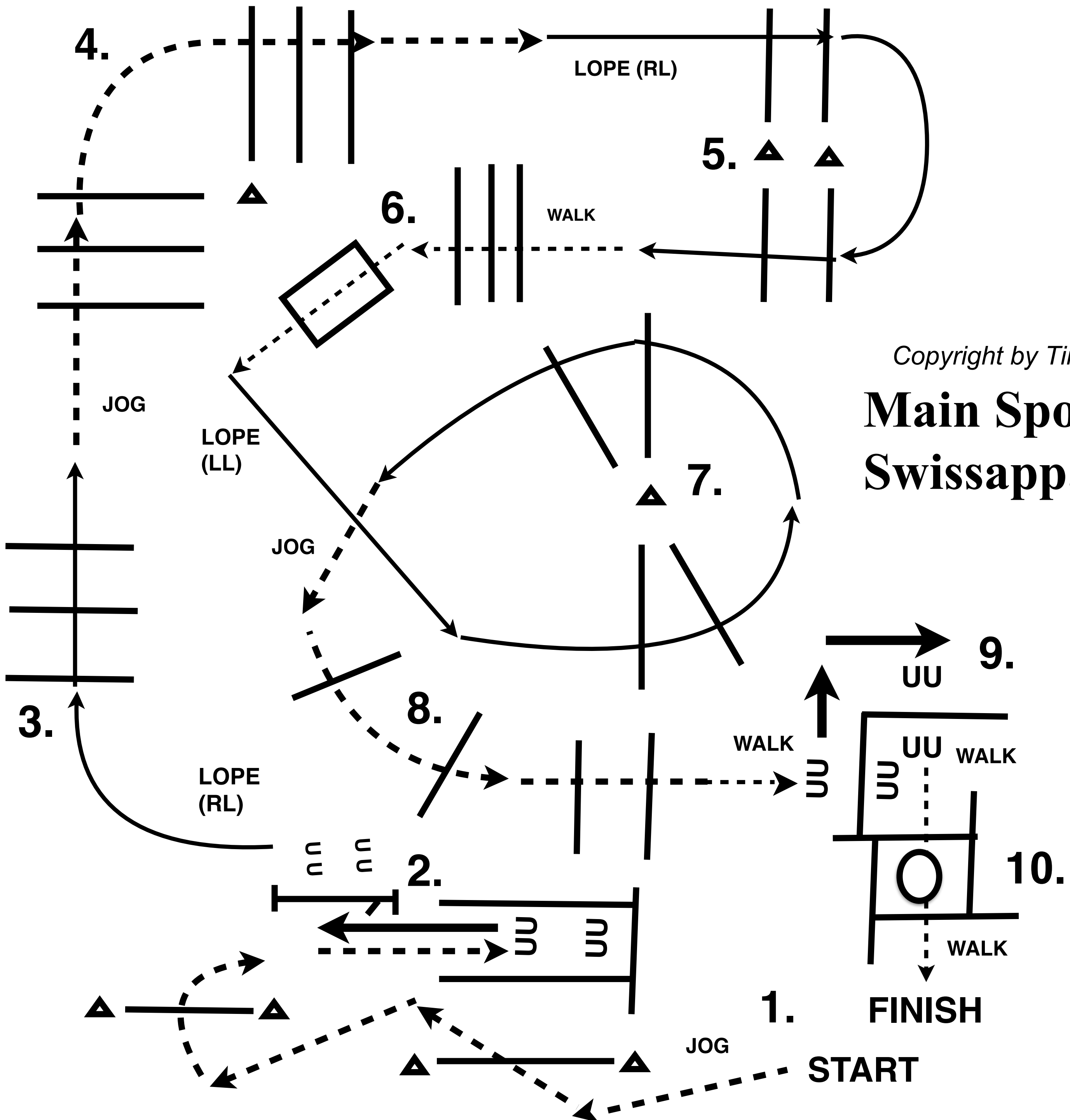

Copyright by Tim Kimura

**Main Sponsor:
Swissappaloosa**

1. JOG OVER POLES JOG INTO THE CHUTE.
2. BACK BETWEEN POES UP TO GATE.
OPEN GATE LH RIDE THRU CLOSE.
3. LOPE OVER POLES (RL).
4. BREAK TO JOG, JOG OVER POLES.
5. LOPE OVER POLES (RL).
6. STOP OR BREAK TO WALK,
WALK OVER POLES AND BRIDGE.

7. LOPE OVER POLES (LL).
8. BREAK TO JOG, JOG OVER POLES.
9. STOP OR BREAK TO WALK,
WALK OVER POLE, SIDE PASS LEFT,
WALK OFF POLE
10. WALK INTO BOX
360 TURN EITHER WAY
WALK OUT BOX