

2013

APPALOOSA HORSE CLUB OFFICIAL HANDBOOK



Martina Filiacova



THE APPALOOSA HORSE CLUB

The International Breed Registry for Appaloosa Horses • Est. 1938

Dear ApHC Member,

Thank you for making the decision to join or renew your membership in the Appaloosa Horse Club! The “power of association” is driven by its members, the connections they make and the passion of a shared purpose. As an organization, the ApHC seeks to strengthen the bond between people and their horses. As a breed, Appaloosas continue to prove their versatility, value and virtues—mostly because of your efforts and the important role you play in advancing the cause.

The *ApHC Official Handbook* is a compilation of rules, policies, guidelines and standards by which we choose to operate. It represents much more than a list of restrictions; it is designed to ensure fair competition, equal consideration and equal opportunity as you participate in the wide range of equine activity. Many of you have provided advice and suggestions for adjustments to various rules. Some of you have helped us anticipate industry trends and changes. All of you have benefitted from having a framework for governance, communication and the overall breed experience.

You are encouraged to solidify that experience through active support of one or more regional clubs and international affiliate partners. Whether your specific interests are showing, breeding, racing, trail riding or something else, an organized community of members at the local level is truly the bedrock of the ApHC. And, be sure to keep up with all things Appaloosa by making regular visits to the official websites as well as the pages of the *Appaloosa Journal*. You might also want to subscribe to the ApHC e-newsletter.

Moving forward, we ask that you accept the assignment of being an Appaloosa ambassador wherever you go. The more we can show positive energy and enthusiasm for our breed, the better our chances of growing as an organization. The ApHC Board of Directors and staff are committed to your future, but the desired outcomes depend on you and your participation.

Thanks for all that you do and best wishes,

Steve Taylor
CEO

ApHC Directory

The Appaloosa Horse Club is on Pacific Time, three hours behind New York, two hours behind Texas, one hour behind Colorado, in the same time zone as California.

Business hours are 8 a.m. to 5 p.m., Monday through Friday.

Administration

Chief Executive Officer—
Steve Taylorext. 249
staylor@appaloosa.com
Administrative Assistant—
Kendra Carlson.....ext. 274
executiveassistant@appaloosa.com

Accounting Department

Treasurer—
Tina Reaext. 234

Appaloosa Journal

journal@appaloosajournal.com
Editor—
Dana Russell.....ext. 237
editor@appaloosajournal.com
Advertising Manager—
Hannah Cassara.....ext. 256
advertising@appaloosajournal.com
Circulation—
(circulation & subscriptions, address
changes, missing & damaged issues,
Appaloosa Journal Xpress)
subscriptions@appaloosajournal.com
Art Director—
Laura Bouma
artdirector@appaloosajournal.com
Projects Director—
John Langstonext. 243
projects@appaloosajournal.com

Information Technology

Information Technology Supervisor—
Dave O'Keefeext. 251
itmanager@appaloosa.com

Marketing Department

Marketing Director—
Merida McClanahanext. 235
marketing@appaloosa.com
regionalclubs@appaloosa.com
Marketing Associate—.....ext. 229
(promotions, mailing list)
promotions@appaloosa.com

Member Services

Membership informationext. 500
membership@appaloosa.com

Museum

www.appaloosamuseum.org
Director—
Crystal Whiteext. 279
museum@appaloosa.com

Racing

Coordinator—
Klancy Allenext. 244
racing@appaloosa.com

Registration Department

General informationext. 300
Registrar—
Shonda Nelson.....ext. 250
Registry Services—
Terry Huttonext. 226
registration@appaloosa.com
Parentage Analysis Coordinator—
Wendy Wilson.....ext. 240
dna@appaloosa.com

Performance Department

General Information..... 400
Performance Department Supervisor—
Keri Minden-LeForceext. 248
kleforce@appaloosa.com
Judge Coordinator and Show Secretary
Klancy Allen.....ext. 244
show-judges@appaloosa.com
showsecretary@appaloosa.com
Show Results/Show Approvals—
Deb Swenson.....ext. 265
show@appaloosa.com
ACAAP/Awards—
.....ext. 224
awards@appaloosa.com
acaap@appaloosa.com
Trail & Distance Coordinator—
Mark Bogar.....ext. 221
trailrides@appaloosa.com
Youth Programs
.....ext. 264
youth@appaloosa.com

FOREWORD

The Appaloosa Horse Club is the international breed registry serving ApHC members and Appaloosa enthusiasts by recording and preserving the horses' heritage and history, and by providing services that promote, enhance and improve the Appaloosa, a breed defined by ApHC bloodline requirements and preferred characteristics, including coat pattern.

This mission statement was adopted by the ApHC Board of Directors in 1992, was amended in 1995 and in 2003, and serves as our reference point in everything we do as an association.

ApHC Animal Welfare Position Statement:

The ApHC is committed to the humane and proper treatment of all animals. In this respect:

- The welfare of the horse is the primary consideration in all activities.
- Horses will be treated with kindness, respect and compassion at all times.
- Responsible care will be used by all parties in handling, treatment and transportation of horses.
- Horse men and women as owners, exhibitors or trainers will ensure the health and well being of animals in their care at all times.
- The standard by which conduct or treatment will be measured is that which a reasonable person, informed and experienced in generally accepted animal husbandry standard and equine care, training and exhibition procedure would determine to be neither cruel, abusive nor inhumane.

Based on their principles, the ApHC has developed and enforces strict rules to ensure ethical competition and humane treatment of Appaloosa horses. The ApHC supports the development of procedures that assure equity, fairness, safety, health and welfare for all participants.

Because the ApHC is strongly opposed to animal abuse, any member convicted in a court of law of cruelty to animals will be suspended from the ApHC when certified evidence is presented to the ApHC disciplinary committee.

This handbook contains Corporation By-Laws, Rules and Regulations of Membership, Registration, Shows, Non-Pro Division, Appaloosa Youth Association and other general information about the breed.

NOTE: NEW RULES OR RULE CHANGES EFFECTIVE JAN. 1, 2013

ARE PRINTED IN BOLD TYPE.



For additional information, please contact:
APPALOOSA HORSE CLUB
2720 W. Pullman Road • Moscow, ID 83843
Telephone: (208) 882-5578 • FAX: (208) 882-8150
www.appaloosa.com
© 2013 Appaloosa Horse Club

TABLE OF CONTENTS

Articles of Incorporation	13
Bylaws	14
Fee Schedule	8
GENERAL RULES	
Board of Directors	43
Code of Ethics	44
Executive Session	44
Definitions	45
Devices and Appliances	40
Disciplinary Procedure	28
Drugs and Medications	34
General Notice Procedure	28
General Violations	32
Inhumane Treatment	32
Information Release Policy	28
Membership	25
Metric Conversion Table	266
Penalties and Sanctions	41
Responsible Party	41
Rules and Regulations	25
REGISTRATION	
Advancement	
from Tentative to Permanent	68
from Non-Characteristic to Regular	67
Age of a Horse	79
Appeal	
Committee	75
Committee Decision	75
of National Event Identification	78
Procedures	75
Application for Registration (see Registration Procedures)	56
Approved Breed	
Associations (see Bloodline Requirements)	53
Listing	56
Ownership Change	56
Artificial Insemination	60
Authorized Signatures	72
Bloodline Requirements	53
Breeder's Certificate	59
Change from Stallion to Gelding or Mare to Spayed Mare	69
Color Change	69
Certificate of Registration	
Corrections to	68
Free Corrections	69
Deceased	
Horses	71
Owners	72
Disposal without Certificate of Registration	72
DNA Testing	62

Duplicate Certificate of Registration	70
Embryo/Oocyte Transfer	61
Embryo Retention Permit	61
Foundation Pedigree Designation	66
Generation Advancement Program	66
Genetic Defects and Undesirable Traits	55
Hardship Registry	57
Horses Not Eligible for Registration	54
HYPP (Hyperkalemic Periodic Paralysis)	55
Identification for National Events	78
Incorrect Applications	58
Inspection Procedures	77
International Registration Incentive Program	63
Leases	72
Name Change	
Horse	70
Owner	69
Name Choices	57
Non-Characteristic Registration	53
Pedigree Certificate (PC)	67
Performance Permit Program	64
Permanent Registration (see Registration Classifications)	51
Processing Fees	58
Protest	
Appeal Procedures	76
Procedures	75
Registration	
Classifications	51
Procedures	56
Rules and Regulations	50
Rush Fees (see Processing Fees)	58
Regular Registration Requirements	53
Replacement Certificate of Registration	71
Required Photographs	56
Re-Registration	
ApHC	70
Reserved Names (see Name Choices)	57
Semen Retention Permit	60
Stallion Breeding Report	58
Syndicates	73
Transfer of Ownership	73
Transported Semen (see Artificial Insemination)	60
RACING	
Awards	
Champion Year-End Horses	87
Medallions	88, 131
Regional High-Point Champions	88
Registers of Merit	86
Cutter and Chariot Racing	88
Governance and Record Keeping	83
Identification Requirements	83
Leases	72, 84

Parentage Verification	83
Race Descriptions	85
Results	85
Speed Index/Rating	86
Starter's Fee (see Race Awards)	85
Transferred and/or Claimed Horses	84

DISTANCE & TRAIL RIDING

Approval Requirements	99
Chief Joseph Commemorative Award	96
Chief Joseph Trail Ride Medallion	98
Competitive and Endurance Program	96
Disabled Riders and Drivers Program	96
Distance Program	95
Enrollment	95
Medallion Program	97, 98, 131
National Trail Rides	99
Recreational Trail Riding Awards	99
Regional Trail Rides	99
1,000 Mile Award	98
Saddle Log	95
Year-End Mileage Award	98

REGIONAL CLUBS

Annual Requirements	80
International Partners	81
Obtaining a New Charter	80
Qualifying Horses for World Show	133
Removal of a Charter	81
State or Area Association	82

APPALOOSA COMPETITIVE ALL-BREED ACTIVITIES PROGRAM (ACAAP)

Approved Categories	93
Awards	93
Enrollment	89
Merit Tabulation	91

SHOW

Age of a Horse (Junior/Senior)	79, 120
Announcer	117
Approval of Shows	106
Youth / Non-Pro	113
Artificial Appliance	40, 142
Bareback Horsemanship	242
Buckboard Driving	224
Camas Prairie Stump Race	191
Cattle Classes	
Attire	148, 194
Equipment	143
Cutting	210
Disqualification	137
Drugs & Medications	34
Eligibility	119

English Performance	225
Attire	228
Equipment	225
Gaits	228
Protective Headgear	228
Entries	118, 121
Equitation General Rules	239
Figure 8 Stake Race	192
Gaming Classes	
Brackets	189
Disclaimer	186
General Rules	186
Horse Against Horse	188
Time Trial Elimination	187
Walk-Trot Classes	193
General Performance Rules	142
Halter	138
Disqualification	137
Foundation Pedigree Designation (FPD)	140
Get of Sire	140
Grand & Reserve Grand Champion	128, 140
Hunter In Hand	141
Most Colorful	140
Produce of Dam	140
Heritage	223
Horsemanship General Rules	239
Hunter Hack	237
Hunter In Hand	141
Hunt Seat Equitation	244
Hunt Seat Equitation Over Fences	246
Hunter Under Saddle	230
Snaffle Bit Hunter Under Saddle	230
Inhumane Treatment	32
Judges	100, 116
Judges—Specialty	105
Jumping	231
Preliminary	234
Keyhole Race	192
Ladies' Side Saddle	224
Lameness	138
Leadline	241
Medallion Awards System	131
Metric Conversion Table	266
Most Colorful at Halter	140
Multi-Judged Shows	111
National Point System	126
Approved Classes	126
Awards	129
Production Awards	131
National/World Show Rules	
Horse Identification	78
Non-Pro Eligibility	263
Youth Eligibility	250
Nez Perce Stake Race	191

Patterns.....	119	Unsportsmanlike Conduct	122
Performance Classes		Veterinarian	125
Age of Junior Horse	120	Western Horsemanship.....	243
Age of Senior Horse	120	Western Performance	143
Disqualification	137	Attire	148
English Performance	225	Equipment	143
General Rules	142	Gaits	149
Western Performance	143	Western Pleasure.....	173
Pleasure Driving.....	229	Hackamore/Snaffle Bit Western Pleasure	173
Production Plaques.....	132	Western Riding.....	166
Reining	151	Working Cow Horse	194
Freestyle.....	165	Hackamore/Snaffle Bit Working Cow Horse	197
Hackamore / Snaffle Bit Reining	154	Patterns	198
Patterns	155	Working Hunter	234
Ring Stewards.....	105, 117	Green Hunter	236
Rope Race	193	Pre-Green Hunter	237
Roping		World Championship Show	
Breakaway Roping	222	Eligibility	133, 135
General Rules	212	National Point Qualification—Non-Pro.....	134, 263
Judged Tie-Down Roping	214	National Point Qualification—Open	133
Judged Heading	217	Non-Pro Eligibility.....	263
Judged Heeling.....	220	Regional Club Qualification	133
Timed Tie-Down Roping	213	World's Best Appaloosa.....	265
Timed Heading and Heeling	216	Yearling Longe Line	176
Saddle Seat Equitation	245		
Saddle Seat Pleasure	238	YOUTH PROGRAM	
Show		Age.....	247
Approval Requirements	106	Awards	
Circuit Shows	111	Annual	250
Drug Testing	118	Horse.....	253
Management General Rules	116	Lifetime	251
Membership Requirements	119	Appaloosa Youth Association	246
Multi-Judged	111	Board of Directors.....	247
Placings	127	Classes Approved for National Points	250
Points (see National Point System)	126	Eligibility to Show	248
Protest	123	World Championship Youth Show	250
Release of Liability	106	Membership	247
Results	115	Novice Youth Program	254
Single-Judge, fee-waiver	110	Ownership	248
Specialty Events	108		
Verification of Entries	118	NON-PRO PROGRAM	
Violations.....	118, 122	Age.....	255
Showmanship at Halter		Awards	
English	240	Annual	259
General Rules.....	239	Horse.....	261
Western	239	Lifetime	261
Special Needs Exhibitor.....	122	Non-Pro Medals.....	259
Specialty Events.....	108	Change of Status	256
Steer Daubing.....	210	Classes Approved for National Points	257
Tail Attachment	40, 142	Definition	255
Team Penning.....	210	Eligibility to Show	256
Trail.....	180	National/World Show	263
Variance	125	Membership	255
		Novice Non-Pro Program	262
		Ownership	256

APPALOOSA HORSE CLUB FEE SCHEDULE—US FUNDS ONLY

Fees submitted by check or money order in US funds only. Master Card and Visa accepted. Bank wiring is also available. Please call for wiring instructions (208) 882-5578.

All prices subject to change without notice

Lifetime Membership.....	\$500.00
Youth One-time Membership.....	75.00
<i>(Valid through the year the Youth is 18 years of age, as of January 1st)</i>	
Individual 3-year Membership.....	\$140.00

Annual Membership

Individual.....	\$55.00
Couple.....	80.00
Family.....	95.00
Replacement Membership Card.....	5.00

Youth Association	10.00
<i>(if purchased separately from family membership)</i>	

Non-Pro Enrollment	10.00
---------------------------------	-------

Limited Participation Membership

Individual.....	\$15.00
-----------------	---------

Registration

	Members	Non-Members
Fillies and Colts		
Foal date to 6th month foal date	\$30.00	\$95.00
After 6th month foal date to 12th month foal date	50.00	115.00
After 12th month foal date to 24th month foal date	100.00	215.00
After 24th month foal date to 36th month foal date	200.00	415.00
After 36th month foal date and thereafter	250.00	515.00

Verified by postmarked date

Example: If foal is born March 5, the customer has until September 5 of year foaled to have the registration application postmarked and to register foal for the \$30 member fee (or \$95 non-member fee)

	Members	Non-Members
Pedigreed Geldings.....	50.00	115.00
Hardship Geldings/Spayed Mares		
Any Age.....	100.00	165.00
Re-Registration (Non-ApHC).....	65.00	135.00
Re-Registration (ApHC).....	50.00	115.00
International Registration		
Incentive Program (IRIP).....	50.00	50.00

Foundation Pedigree Designation (non-refundable).....	20.00	85.00
Generation Advancement Program (non-refundable).....	20.00	85.00

Transfer of Ownership (including track transfers).....	15.00	80.00
Correction of Transfer.....	20.00	20.00

All prices subject to change without notice

	Members	Non-Members
Stallion Breeding Report Filing (non-refundable).....	25.00	90.00
Plus Mares.....	5.00 ea	18.00 ea
Late Filing fee.....	30.00	95.00
Late filing fee is in addition to on-time filing fees. Applicable for reports post-marked after November 30 of breeding year. Breeding reports for stallions standing in the Southern hemisphere must be postmarked on or before June 30 of breeding season.		

Adding Mare to Stallion Breeding Report.....	10.00	35.00
Photocopy of Stallion Breeding Report.....	5.00 per pg	5.00 per pg

Approved Breed Listing.....	50.00	115.00
Frozen Embryo Retention Permit.....	50.00	115.00
Frozen Semen Retention Permit.....	50.00	115.00
Retention Permit Transfer Fees.....	15.00	80.00

Embryo/Oocyte Transfer

Mare Enrollment.....	100.00	100.00
Late Enrollment:		
After Collection/Prior to Foaling.....	25.00	25.00
After Foaling.....	50.00	50.00

Performance Permit

Foal date to 24th month foal date:		
Appaloosa x Appaloosa.....	150.00	215.00
Appaloosa x Approved Breed.....	250.00	315.00

After 24th month foal date:

Appaloosa x Appaloosa.....	300.00	365.00
Appaloosa x Approved Breed.....	500.00	565.00

DNA Testing Kit.....	50.00	50.00
DNA Waiver.....	20.00	20.00
HYPP and DNA Test.....	100.00	100.00
HYPP Test.....	50.00	50.00
HYPP Test on Stored Sample.....	50.00	50.00
Blood Typing.....	125.00	125.00

Tattoo.....	65.00	65.00
Inspection.....	175.00 per day	175.00 per day
	87.50 per half day	87.50 per half day

Parentage Exclusion Analysis.....	25.00 per hour
<i>(Estimates provided prior to service.)</i>	

Advancement from Non-Characteristic (N) to Regular (#) (non-refundable).....	25.00	25.00
Advancement from Tentative to Permanent	10.00	10.00

All prices subject to change without notice

Duplicate Certificate of Registration 20.00 20.00

Members Non-Members

Correction of Certificate of Registration 20.00 20.00

Horse Name Change 100.00 100.00

Change to Gelding

Certificate Stamped No Charge

New Certificate of Registration 20.00 20.00

Lease Filing 20.00 20.00

Office Charge for Closing Transaction

on Incomplete Registration Work 20.00 20.00

Computer Flagging

(contact office—expires after one year) 25.00 25.00

*Rush 50.00 115.00
(maximum 10 working days to process—non-refundable)*Special Attention Rush 100.00 165.00
(maximum 48 hours to process—non-refundable)

*Note: The processing time listed for rush fees commences with the receipt of the work at the ApHC. If a “rush” request is upgraded to a “special attention rush,” only an additional \$50 will be assessed.

Protest Fees

Parentage 1000.00

Classification or Status 500.00

Show 250.00

Appeal Fees

Registration 500.00

Show 250.00

Other Fees

Race Starter’s Fee 10.00

Race Medallion Permit 100.00

Late Race Starter’s Fee 100.00

Show Approval (per judge) 25.00 50.00

Saddle Log Fee (paid annually) 15.00

Distance Program Enrollment

(one-time fee per horse) 25.00

Judges Card Renewal (paid annually) 25.00

5-Generation Pedigree 15.00

4-Generation Color Pedigree 20.00

4-Generation Show/Race Pedigree 25.00

3-Generation Combination Pedigree 25.00

Computer Print-Outs:

Get of Sire 5.00 per horse

Produce of Dam 5.00 per horse

Sire/Dam Statistics 5.00 per horse

National Points Records 5.00 per exhibitor or horse

Official Handbook of the ApHC (Duplicate) ... 5.00

All prices subject to change without notice

Priority Return Shipping (letter rate)

Call for rates

UPS Next Day \$25.00

US Postal Express Mail \$20.00

Certified \$6.00

HISTORY

The Appaloosa is a distinctive breed of horse. Appaloosas have characteristics that set them apart from other breeds in the equine world.

Drawings of horses displaying this rare Appaloosa color scheme have been found in the caves of Early Man in France, making them prehistoric. Spotted horses later appear in Chinese artistry dating from 500 B.C. and Persian art of the 14th century, and throughout most of Europe. One theory on how Appaloosas came to the Americas is that they were imported from the Near East or Spain with shipments of goods to Mexico about 1600. The spread of the horses northward was made by the Plains Indians and by about 1730, the Nez Perce had them. During the exploration of the West, the Nez Perce were the only tribe to have Appaloosas in numbers. The Nez Perce were obviously pleased with their intelligence, stamina and colorful markings as they chose to breed them in preference to other horses from the 1730s to the 1830s. The Nez Perce bred their colorful horses to a distinctive type able to stand the rigors of mountain travel. They only bred their best animals and gelded or traded the poorer ones. The area inhabited by the Nez Perce, which is the northeast corner of Oregon, the southeast corner of Washington and the bordering Idaho country, was ideal for horse production, providing lush summer range in the hills and meadows and abundant winter range in the sheltered canyons of the Snake, Palouse and Clearwater Rivers. The Nez Perce were fond of racing, with finish lines set from a hundred yards to as far as 12 miles. Performance helped guide the Indians in eliminating the slow.

Close contact with the people of the tribe demanded a quiet, sensible disposition. This trait is common to Appaloosas today. The combination of stamina needed for racing and hunting, and disposition and good sense necessary for life around the camp tended to produce a superior horse.

The breed nearly disappeared after the Nez Perce War of 1877. The Nez Perce, led by Chief Joseph, made a daring 1,350-mile dash to Canada over some of the most rugged terrain in the West, outrunning five U.S. Armies while transporting goods, women and children. But for a telegraph line and handy steamer to ferry troops across the Missouri, they would have made it.

After the surrender of Joseph at the Bear Paw Mountains in Montana, the Appaloosas bred to perfection by the Nez Perce were sold and began to become assimilated into other breeds.

The Appaloosa Horse Club, the official breed registry for Appaloosas, was formed in 1938 by a group of men determined to keep the famed Nez Perce war and hunting horses from slipping out of sight forever. A few of the descendants of the Nez Perce horses made up the foundation stock. Since then the growth of the Appaloosa Horse Club has been rapid.

The Indians preferred the Appaloosa for war, hunting and racing. Modern uses of the colorful breed are variations on a “can do” theme, ranging from parade, show, cow horse, trail, pleasure, polo, racing to jumping. Horsemen claim if a horse can do it, you can be sure an Appaloosa has done it... and well.

The Appaloosa Horse Club was organized in 1938 with the following objectives: to collect records and historical data relating to the origin of Appaloosas; to file records and issue certificates of registration for animals thought to be fit foundation stock of the breed; to preserve, improve and standardize the breed of spotted horses known in the Northwest as Appaloosas. The Appaloosa Horse Club, Moscow, Idaho, is the National Breed Association and official registry for Appaloosa Horses.

APPALOOSA BREED STANDARD

GENERAL CONFORMATION:

- Symmetrical and smooth: head is straight and lean, giving eye prominence and adding distinction to head appearance; ears are pointed and of medium size; neck shows quality with a clean cut throat latch and a large windpipe.
- Chest is deep and blends into well muscled sloping shoulders; withers are prominent and well defined; forearm is well muscled, long wide and tapered down to a broad knee; cannons are wide and flat with wide, smooth and strongly supported fetlocks; pastern is medium long and sloping; hooves are rounded, deep, open and wide at the heels; back is short and straight; loin is short and wide; underline is long with the flank well let down; hips are smoothly covered, being long, sloping and muscular; thighs are long, muscular and deep, blending into well rounded quarters; gaskins are long wide and muscular extending to clean clearly defined wide, straight hocks.
- Forelegs, when viewed from the front, should have a perpendicular line from the point of the shoulder that should fall upon the center of the knee, cannon, pastern and foot. From the side, a perpendicular line from the center of the elbow joint should fall upon the center of the knee and pastern joints and back of foot.
- Rear legs, when viewed from behind, should have a perpendicular line from the point of the hindquarter that should fall upon the center of the hock, cannon, pastern and foot. From the side, a perpendicular line from the hip joint should fall upon the center of the foot and divide the gaskin in the middle, and a perpendicular line from the point of the quarter should run parallel with the line of the cannon.
- Minimum height for a mature Appaloosa (5 years or older) is 14 hands. There is no maximum height. Height and weight should be proportional.

COLOR AND COAT PATTERNS:

- The base coat color may be any one of many different colors and can include dilutes, duns, grays, roans and other modifying types. Eyes may be any color, including, but not limited to, blue, hazel, green, brown, amber and black. Coat color patterns may vary from a solid pattern, meaning no spotting at all, to multi-spotted to blanket hipped with no spots. Patterns and markings are extremely varied and found in many sizes and combinations with great variations in areas with white backgrounds. Appaloosas can dramatically change their coat pattern throughout their lifetime. No two Appaloosa horses are identically marked.
- While color and markings are not primary or determinative factors in judging, it should be borne in mind that where two horses are equal in type, conformation, action and soundness, the award may be made to that particular entry which is more reasonably recognizable as an Appaloosa.

SECONDARY CHARACTERISTICS:

- Mottled or parti-colored skin may be found around the nostrils, mouth, eyes, anus and genitals. This characteristic may be found present in only one area, several areas or none at all.
- Sclera of eyes may be white. Sclera may be in one, both or neither eye.
- Hooves may be striated with dark and light striping in the hoof wall. Striation may or not be present in any or all feet.

RESTATED ARTICLES OF INCORPORATION OF APPALOOSA HORSE CLUB

Pursuant to the provisions of the Oregon Nonprofit Corporation Law the undersigned corporation adopts the following Restated Articles of Incorporation:

ARTICLE I

Name and Duration

The name of the corporation is APPALOOSA HORSE CLUB, and its duration shall be perpetual.

ARTICLE II

Purposes and Powers

The purposes for which the corporation is organized are:

- A. To preserve, improve and standardize the breed of horses known as Appaloosa;
- B. To establish, maintain and publish a registry for recording pedigrees and transfers of ownership of Appaloosa horses;
- C. To promote the breeding, use, and exhibition of Appaloosa horses;
- D. To collect and record data about the origin and development of Appaloosa horses; and
- E. Subject to the restrictions set forth in these Restated Articles of Incorporation, to engage in any other lawful activities, none of which shall be for profit, for which corporations may be organized under the Oregon Nonprofit Corporation Law.

In furtherance of the foregoing purposes the corporation shall have and may exercise all the rights and powers given to nonprofit corporations under the Oregon Nonprofit Corporation Law.

ARTICLE III

Restrictions

This corporation is intended to qualify as a tax-exempt organization within the meaning of Section 501 (c)(5) of the Internal Revenue Code of 1954, as amended. Notwithstanding any provision of these Restated Articles of Incorporation apparently to the contrary, the affairs of the corporation shall be conducted in such a manner as to qualify for tax exemption under that Section or the corresponding provision of any future Federal tax laws. No part of the net earnings of the corporation shall inure to the benefit of any member.

ARTICLE IV

Board of Directors

- A. The affairs, business and property of the corporation shall be managed and controlled by its Board of Directors consistent with the Oregon Nonprofit Corporation Act and Bylaws of the corporation. Directors of the corporation shall be designated and elected as set forth in the Bylaws of the corporation.

ARTICLE V

Dissolution

Upon dissolution or final liquidation of the corporation, after payment or provision for payment of all of the liabilities of the corporation, the remaining assets of the corporation shall be distributed to the Appaloosa Youth Foundation if such Foundation is then a tax exempt organization pursuant to Section 501 (c)(3) of the Internal Revenue Code of 1954, or corresponding provision of any future Federal tax laws. Otherwise, such remaining assets of the corporation shall be distributed to such tax exempt organization or organizations selected by the Board of Directors which are related to or share the purposes of this corporation and are exempt from Federal income taxation pursuant to Section 501 (c)(3) or Section 501 (c)(6) of the Internal Revenue Code of 1954, or corresponding provisions of any future Federal Tax Laws.

ARTICLE VI

Indemnification

The corporation shall indemnify to the fullest extent permitted by the Oregon Nonprofit Corporation Law any person who is made, or threatened to be made, a

party to an action, suit or proceeding, whether civil, criminal, administrative, investigative or otherwise (including an action by or in the name of the corporation), by reason of the fact that the person is or was a director or officer of the ApHC or serves or served at the request of the ApHC as a director or officer of any other corporation. The entitlement of any person to indemnification hereunder and the amount of that indemnification shall be determined in accordance with the procedures and other provisions set forth in the Oregon Nonprofit Corporation Law in effect at the time of the determination.

ARTICLE VII

Amendments of Articles

Any amendment, restatement or other alteration of these Restated Articles of Incorporation adopted in accordance with the procedures and other provisions set forth in the Oregon Nonprofit Corporation Law shall thereafter be submitted to a vote of the members of the corporation entitled to vote on Articles by means of a ballot provided according to voting procedures permitted by the Oregon Nonprofit Corporation Law and determined from time to time by the ApHC Board of Directors and shall not be effective unless approved by at least two-thirds of the votes cast.

BY LAWS OF APPALOOSA HORSE CLUB

ARTICLE I

Purposes, Powers and Offices

Section 1. Purposes and Powers. The purposes for which the Appaloosa Horse Club (ApHC) is organized and shall be operated are:

- A. To preserve, improve and standardize the breed of horses known as Appaloosa;
- B. To establish, maintain and publish a registry for recording pedigrees and transfers of ownership of Appaloosa horses;
- C. To promote the breeding, use and exhibition of Appaloosa horses;
- D. To collect and record data about the origin and development of Appaloosa horses; and
- E. Subject to the restrictions set forth in the Restated Articles of Incorporation of the ApHC, to engage in any other lawful activities, none of which shall be for profit, for which corporations may be organized under the Oregon Nonprofit Corporation Law.

In furtherance of the foregoing purposes the ApHC shall have and may exercise all of the rights and powers given to nonprofit corporations under the Oregon Nonprofit Corporation Law.

Section 2. Offices. The ApHC may have such offices as the Board of Directors may determine or the affairs of the ApHC may require from time to time. The principal office of the ApHC may be changed from time to time by the Board of Directors; provided, however, that any such proposed change shall first be submitted to the members of the ApHC for approval by means of a ballot provided by the ApHC according to ApHC voting procedures as determined from time to time by the ApHC Board of Directors and any such proposed change shall not be made unless approved by a majority of the votes cast.

The ApHC shall have and continuously maintain in the State of Oregon a registered office, and a registered agent whose office is identical with such registered office, as required by the Oregon Nonprofit Corporation Law. The registered office may be, but need not be, identical with the principal office in the State of Oregon, and the address of the registered office may be changed from time to time by the Board of Directors.

Section 3. Parliamentary Governance. The rules contained in the current edition of "Robert's Rules of Order, Newly Revised," shall govern the ApHC in all circumstances to which said rules are applicable and in which they are not in conflict or inconsistent with Bylaws and/or special rules of order the ApHC may adopt from time to time.

ARTICLE II

Members

Section 1. Classes of Members. The ApHC shall have two classes of members. The designation of such classes and the qualifications of the members of such classes shall be as follows:

- A. Regular Members. A regular member shall be any person whose membership application has been approved by the Chief Executive Officer in accordance with Section 2 of this Article II and any person formerly known as a life member. The following persons shall be eligible to apply for regular membership in the ApHC.
 1. Any person owning an Appaloosa horse eligible for registration with the ApHC or demonstrating an interest in Appaloosa horses.
 2. Any person associated with the Appaloosa horse industry, such as a trainer, exhibitor, supplier, veterinarian, show manager, farrier, or approved judge, steward or ring master.
- B. Honorary Life Members. Each director of the ApHC shall be appointed an honorary life member by the Board of Directors immediately upon the expiration of the director's term of office, provided that the former director is then in good standing with the ApHC. The Board of Directors may elect to honorary life membership any other person who for special reasons may be deemed entitled to this privilege. All such honorary life members shall be entitled to all of the privileges and rights of an active member. Honorary life members shall not be required to pay an initiation fee or annual dues.

Section 2. Appointment of Regular Members. Regular members shall be appointed by the Chief Executive Officer in accordance with the provisions of this SECTION 2. All applicants for regular membership shall file with the Chief Executive Officer a written application in such form as the Board of Directors shall from time to time determine. The Chief Executive Officer shall pass upon each application and shall approve or reject it in accordance with such rules and regulations as adopted from time to time by the Board of Directors.

Section 3. Voting Rights. Each active member in good standing shall be entitled to one vote on each matter submitted to a vote of the members except that members shall have the right to nominate candidates and vote in elections of directors only to the extent authorized by Section 3 of Article IV of these Bylaws.

Section 4. General Privileges and Obligations. Active members in good standing shall have equal rights and privileges, except as otherwise limited by these Bylaws. All members shall obey and be bound by these Bylaws, by the rules and regulations adopted from time to time by the Board of Directors and by the decisions and actions of the Board.

Section 5. Disciplinary Rules. Members may be disciplined, expelled, or suspended for cause after an appropriate hearing in accordance with such rules and regulations as adopted from time to time by the Board of Directors.

Section 6. Resignation. Any member may resign by filing a written resignation with the Chief Executive Officer, but such resignation shall not relieve the member so resigning of the obligation to pay any dues, assessments or other charges for which the member became liable prior to resignation.

Section 7. Reinstatement. Upon written request signed by a former member and filed with the Chief Executive Officer, the Board of Directors may, by the affirmative vote of at least two-thirds of the directors in office, reinstate such former member to membership upon such terms as the Board of Directors may deem appropriate.

Section 8. Transfer of Membership. Membership in the ApHC shall not be transferable.

ARTICLE III

Meetings of Members

Section 1. Annual Meeting. An annual meeting of the members shall be held in conjunction with the National Appaloosa Horse Show at a time and date during June, July or August of each year as determined by the Board of Directors, for the purpose of receiving annual reports relating to the activities of the ApHC and for the transaction of such other business as may come before the meeting.

Section 2. Special Meetings. Special meetings of the members may be called by the President, the Board of Directors, or not less than two-tenths of the members having the right to vote at such meeting.

Section 3. Place of Meeting. The Board of Directors may designate any place, either within or without the State of Oregon, as the place of meeting for any annual meeting or for any special meeting called by the Board of Directors. If a special meeting be otherwise called, the place of meeting shall be as designated in the notice of such meeting.

Section 4. Notice of Meetings. Written notice stating the place, day and hour of any meeting of members shall be delivered personally or sent by mail, e-mail or other form of wire or wireless communication, to each member entitled to vote at such meeting, not less than 30 nor more than 50 days before the date of such meeting, by or at the direction of the President, or the Chief Executive Officer, or the officers or persons calling the meeting. In the case of a special meeting or when required by statute or by these Bylaws, the purpose or purposes for which the meeting is called shall be stated in the notice. If mailed, such notice of a meeting shall be deemed to be delivered when deposited in the United States mail addressed to the member at the member's address as it appears on the records of the ApHC, with postage thereon prepaid. If notice be given by e-mail or other form of wire or wireless communication, such notice shall be deemed delivered to the member if transmitted to the member's e-mail address and/or other wire and/or wireless-based address as it appears on the records of the ApHC.

Section 5. Informal Action by Members. Any action required by law to be taken at a meeting of the members, or any action which may be taken at a meeting of members, may be taken without a meeting if a consent in writing, setting forth the action so taken, shall be signed by all of the members entitled to vote with respect to the subject matter thereof.

Section 6. Quorum. Those members present at any annual or special meeting of members shall constitute a quorum at such meeting.

Section 7. Voting. At any special or annual meeting of members, a member entitled to vote may vote only in person and not by proxy. The nomination and election of directors shall be conducted according to these Bylaws and ApHC election procedures as determined from time to time by the ApHC Board of Directors.

Section 8. Manner of Acting. A majority of the votes entitled to be cast on a matter to be voted upon by the members present at a meeting at which a quorum is present shall be necessary for the adoption thereof unless a greater proportion is required by law or by these Bylaws.

ARTICLE IV

Board of Directors

Section 1. General Powers. The affairs, business and property of the ApHC shall be managed and controlled by its Board of Directors consistent with the Oregon Nonprofit Corporation Act and these Bylaws. The Board of Directors may adopt rules and regulations governing the rights, privileges and obligations of members not

inconsistent with these Bylaws. The Board of Directors may affiliate the ApHC with ApHC Regional Clubs, International Affiliates and/or other organizations that share the purposes of the ApHC upon such terms and conditions and in such manner as determined from time to time by the Board of Directors.

Section 2. Qualifications, Number, Term, Nomination, Election and Member Voting.

- A. To be eligible to serve as an ApHC director, a person must be an active member in good standing of the ApHC and have been an active member in good standing of the ApHC for at least three (3) consecutive years next preceding the applicable election and elected in accordance with these Bylaws from the geographical zone set forth in Section 3 of this Article IV where such person is domiciled. Any member who, as the result of ApHC disciplinary action, has been determined guilty of a violation of any ApHC Rules and Regulations shall be ineligible to hold the position of director. Any member who has been convicted of a crime punishable by imprisonment in a State or Federal prison, or who has been convicted of a crime involving moral turpitude shall be ineligible to hold the position of director. If a director becomes not domiciled within the geographical zone from which elected or ceases to be an active member in good standing of the corporation, such director shall thereafter be ineligible to continue to serve as a director and the Board of Directors shall immediately remove such director from the Board of Directors and the vacancy shall be filled in accordance with these Bylaws.
- B. The number of directors shall be nineteen (19). One (1) director shall be elected from each of the geographical zones set forth in Section 3 of this Article IV.
- C. To be nominated for election as a director, a member qualified to be a director must submit a petition, on a form approved by the ApHC. In a regular election, the petition must be submitted on or before the last day of July in the election year and in a special election the petition must be submitted as required by the ApHC Board of Directors, nominating such member for election from the geographical zone where such member is domiciled. The nominating petition must be signed by at least five (5) ApHC members in good standing domiciled in the same territory as the member being nominated.
- D. The regular election of directors shall occur in September, October and/or November of each year. Only ApHC members in good standing as of August 31 each year shall be eligible to vote in the regular election that year. The ApHC Board of Directors may establish the membership eligibility deadline for special election and other purposes.
- E. Each active member in good standing shall be entitled only to one (1) vote on all matters upon which such member is entitled to vote.
- F. The ApHC shall prepare a ballot for each geographical zone for which an election is being held that includes all members properly nominated for election as a director from that geographical zone. If only one (1) member is properly nominated for election as director from a geographical zone, that nominee shall be deemed elected as director without conducting the election. In the event there is no member properly nominated for election as a director from a geographical zone, the ApHC Board of Directors shall appoint a qualified ApHC member to any such director position for the full term of three (3) years. Otherwise, the ApHC shall provide the ballot according to the ApHC election procedures as determined from time to time by the ApHC Board of Directors for each geographical zone to all eligible ApHC voting members residing within the Territory in which such geographical zone is located and each such member shall be entitled to vote in the election of all directors from that Territory whether or not the member resides within the zone from which a director is to be elected. Ballots must be completed and submitted according to ApHC election procedures as determined from time to time by the ApHC Board of Directors.
- G. The nominee receiving the highest number of votes on the ballot for each geographical zone will be named director. In the event two or more candidates

receive the same and highest number of votes in the election of a director, the candidate with the most votes from the geographical zone in which the candidates are domiciled shall be elected director and if two or more candidates also receive the same and highest number of votes from the geographical zone in which the candidate are domiciled, a runoff election shall be held between such candidates.

- H. Directors (i) elected at the regular election of directors shall be elected to serve, (ii) deemed elected as a director without conducting the election as provided under Section 2.F. of this Article IV shall be deemed to serve and (iii) appointed by the Board of Directors as provided under Section 2.F. of this Article IV shall be appointed to serve; for a term of approximately three (3) years commencing at the commencement of the regular meeting of the Board of Directors next held following the regular election of directors at a time and date during January through April as determined by the Board of Directors and ending upon the taking of the oath by the successor director at such meeting in the third (3rd) year following the commencement of such terms. The terms of office for directors shall be staggered so that the term of either one-third (1/3) of the total number of directors or one-third (1/3) plus one (1) of the total number of directors, as applicable, expire each year.
- I. All elections of directors of the ApHC and all votes of the membership for any purpose must be conducted and managed by a National or regional independent accounting firm other than that firm contracted by the ApHC to perform auditing and reporting functions on a regular basis. No interim counting or tallies will be released to anyone.

Section 3. Geographical Territories and Zones.

- A. For the purpose of elections of directors, the membership of the ApHC shall be divided into the geographical territories and zones set forth below:

TERRITORY I

Zone A-Washington, Oregon, Alaska, British Columbia and Yukon Territory
Zone B-Idaho, Montana, Wyoming, Alberta and Northwest Territories
Zone C-North Dakota, South Dakota, Minnesota, Saskatchewan,
Manitoba and Nunavut

TERRITORY II

Zone A-California and Hawaii
Zone B-Nevada, Utah, Arizona, New Mexico, Mexico and International Affiliates
in the Southern Hemisphere, Central America and South America
Zone C-Colorado and Kansas

TERRITORY III

Zone A-Missouri and Nebraska
Zone B-Iowa and Wisconsin
Zone C-Illinois and Indiana

TERRITORY IV

Zone A-Texas
Zone B-Oklahoma and Louisiana
Zone C-Florida and Alabama

TERRITORY V

Zone A-Arkansas, Tennessee and Mississippi
Zone B-Georgia, South Carolina and North Carolina
Zone C-Kentucky, Virginia, West Virginia, Delaware, District of Columbia and Maryland

TERRITORY VI

Zone A-Michigan and Ohio
Zone B-Pennsylvania, New York and Ontario
Zone C-New Jersey, Vermont, New Hampshire, Maine, Connecticut, Massachusetts, Rhode Island, Quebec, New Brunswick, Nova Scotia, Prince Edward Island and Newfoundland

TERRITORY VII

European Zone-All International Affiliates not otherwise specifically listed in another zone (e.g. England, France, Germany, Hungary, Israel, Italy, Japan, Luxembourg, Switzerland and other countries that may be added)

- B. The Board of Directors may, from time to time, recommend further revisions to the territories and zones for the purpose of achieving a reasonably equal geographic distribution of the membership, but such recommendations, if made, shall not be made more frequently than every six years.

Section 4. Regular Meetings. A regular meeting of the Board of Directors shall be held anytime after the annual meeting of members each year at a time and date during July through December as determined by the Board of Directors. The Board of Directors may provide by resolution the time and place, either within or without the State of Oregon, for the holding of additional regular meetings of the Board without other notice than such resolution.

Section 5. Special Meetings. Special meetings of the Board of Directors may be called by or at the request of the President or a majority of the number of directors fixed by Section 2 of Article IV of these Bylaws. The person or persons authorized to call special meetings of the Board may fix any place, either within or without the State of Oregon, as the place for holding any special meeting of the Board called by them.

Section 6. Notice. Notice of any special meeting of the Board of Directors shall be given at least 20 days previously thereto by written notice delivered personally or sent by mail, e-mail or other form of wire or wireless communication to each director at the director's address as shown by the records of the ApHC. If mailed, such notice shall be deemed to be delivered when deposited in the United States mail so addressed, with postage thereon prepaid. If notice be given by e-mail or other form of wire or wireless communication, such notice shall be deemed delivered to the director if transmitted to the director's e-mail address and/or other wire and/or wireless-based address as it appears on the records of the ApHC. Any director may waive notice of any meeting. The attendance of a director at any meeting shall constitute a waiver of notice of such meeting, except where a director attends a meeting for the express purpose of objecting to the transaction of any business because the meeting is not lawfully called or convened. Neither the business to be transacted at, nor the purpose of any regular or special meeting of the Board need be specified in the notice or waiver of notice of such meeting, unless specifically required by law or by these Bylaws.

Section 7. Presumption of Assent. A director of the ApHC who is present at a meeting of the Board of Directors at which action on any corporate matter is taken shall be presumed to have assented to the action taken unless the director's dissent to the action as entered in the minutes of the meeting or unless a written dissent to the action is filed with the person acting as secretary of the meeting before the adjournment thereof or forwarded by certified or registered mail to the Chief Executive Officer of the ApHC immediately after the adjournment of the meeting. The right to dissent shall not apply to a director who voted in favor of the action.

Section 8. Quorum and Attendance at Meetings. A majority of the number of directors fixed by Section 2 of this Article IV shall constitute quorum for the transaction of business at any meeting of the Board; but if less than a quorum is present at said meeting, a majority of the directors present or a sole director present may adjourn the meeting from time to time and, if necessary, to a different place, without further notice. The Executive Committee of the ApHC Board of Directors may conduct a regular or special meeting of the ApHC Board of Directors and permit all Directors to participate in any such meeting through the use of any means of communication by which all Directors participating may simultaneously hear each other during any such meeting. A director participating by any such means is deemed to be in attendance and present at any such meeting for all purposes under the Bylaws.

Section 9. Manner of Acting. The act of a majority of directors present at the meeting at which a quorum is present shall be the act of the Board of Directors, unless the act of a greater number is required by law or by these Bylaws. All motions made at any meetings of the ApHC Board of Directors, including committee meetings, must be by roll call and each roll call voting record must be published and distributed to the members within sixty days of that meeting.

Section 10. Vacancies. Any vacancy occurring on the Board of Directors and any directorship to be filled by reason of an increase in the number of directors may be filled by the affirmative vote of a majority of the remaining directors, though less than a quorum of the Board of Directors; provided, however, that a special election by members shall be conducted consistent with the provisions of these Bylaws if the unexpired term of the vacancy to be filled exceeds one year. The Board of Directors may make a temporary appointment of any directorship to be filled by appointing an ApHC member domiciled in the affected geographical zone pending such special election as required above. A director elected to fill a vacancy shall be elected for the unexpired term of the director's predecessor in office.

Section 11. Removal.

- A. Any director may be removed from office, with or without cause, at a meeting of members called expressly for that purpose, by a vote of a majority of all members then entitled to vote in an election of such director.
- B. Any elected director who is absent without good cause from two (2) consecutive meetings of the Board of Directors is subject to removal as a director by affirmative vote of at least two-thirds (2/3) of all directors at a Board of Directors meeting.
- C. Throughout his/her tenure, a director must conduct himself/herself in an exemplary manner such as to favorably reflect on the ApHC and the ApHC Board of Directors. A director's conduct is subject to continual review and a director's office and service on the Board of Directors may be terminated and/or rejected by the Board of Directors for cause detrimental to the interest of the ApHC, its programs, policies, objectives and/or the harmonious relationship of its members. A proceeding to so terminate or reject a director's office and service must be initiated upon written complaint signed by a director specifying the alleged cause and filed with the Chief Executive Officer, and upon a determination by the ApHC Executive Committee that such complaint sets forth sufficient prima facie evidence in support of the alleged cause, the Board of Directors shall:
 - i. give at least thirty (30) days written notice of hearing to the director charged by said complaint and;
 - ii. hold a hearing before the Board of Directors, excluding the director charged and the director initiating the complaint, at which hearing the director charged and the director initiating the complaint shall have the right to be represented by legal counsel, each at their own expense unless otherwise indemnified under ApHC Bylaws or applicable law, call witnesses, present evidence and testimony under oath, offer evidence, cross-examine adverse witnesses and provide rebuttal testimony and evidence.

At the conclusion of the hearing and upon an affirmative vote by at least three-fourths (3/4ths) of the directors then in office, excluding the director charged and the director initiating the complaint, deciding that such detrimental cause exists, the charged director's office and service on the ApHC Board of Directors shall be immediately terminated and/or rejected, and, if such affirmative vote is not attained, the complaint shall be dismissed.

Section 12. Compensation. Directors shall not receive any stated salaries for their services as directors or officers, but by resolution of the Board of Directors may be paid for their expenses, if any, of attendance at each meeting of the Board, and may be paid their expenses incurred in the performance of the business of the ApHC as previously authorized by the Board of Directors or the President; but nothing herein contained shall be construed to preclude any director from serving the ApHC in any other capacity and receiving compensation therefore.

Section 13. Informal Action by Directors. Any action required by law to be taken at a meeting of directors, or any action which may be taken at a meeting of directors, may be taken without a meeting if a consent in writing, setting forth the action so taken shall be signed by all of the directors.

ARTICLE V

Officers

Section 1. Officers. The officers of the ApHC shall be a President, a Vice President, a Chief Executive Officer and a Treasurer. The Board of Directors may elect or appoint such other officers or assistant officers as it shall deem desirable, such officers to have the authority and perform the duties prescribed from time to time by the Board of Directors. Any two or more offices may be held by the same person, except the offices of President and Chief Executive Officer.

Section 2. Election, Appointment, and Terms of Office. The President and Vice President shall be elected annually by and from the members of the Board of Directors and at the regular meeting of the Board of Directors as provided under Section 2.H. of Article IV of these Bylaws. If the election of such officers shall not be held at such meeting, such election shall be held as soon thereafter as conveniently may be. The Chief Executive Officer and the Treasurer shall be appointed by the Board of Directors, but shall not be members of the Board of Directors, for terms not exceeding three years. Appointments may be renewed for successive three-year periods. The terms of such appointments, including salaries and duties, shall be determined from time to time by the Board of Directors. Each officer shall hold office until the officer's successor shall have been duly elected or appointed and shall have qualified.

Section 3. Removal. Any officer elected or appointed by the Board of Directors may be removed by the Board of Directors whenever in its judgment and best interests of the ApHC would be served thereby, but such removal shall be without prejudice to the contract rights, if any, of the officers so removed.

Section 4. Vacancies. A vacancy in office because of death, resignation, removal, disqualification or otherwise may be filled by the Board of Directors for the unexpired portion of the term.

Section 5. President. The President shall preside at all meetings of the members and of the Board of Directors. The President may sign, with the Chief Executive Officer or any other proper officer of the ApHC authorized by the Board of Directors, any deeds, mortgages, bonds, contracts, and other instruments which the Board of Directors has authorized to be executed, except in cases where the signing and execution thereof shall be expressly delegated by the Board of Directors or by these Bylaws, or by statute to some other officer or agent of the ApHC; and in general the President shall perform all duties incident to the office of President and such other duties as may

be prescribed by the Board of Directors from time to time.

Section 6. Vice President. In the absence of the President or in the event of the President's inability or refusal to act, the Vice President shall perform the duties of the President, and when so acting, shall have all the powers of and be subject to all the restrictions upon the President. The Vice President shall perform such other duties as from time to time may be assigned by the President or by the Board of Directors.

Section 7. Chief Executive Officer. The Chief Executive Officer shall keep full and accurate minutes of the meetings of the members and of the Board of Directors in one or more books provided for that purpose; see that all notices are duly given in accordance with the provisions of these Bylaws or as required by law; be custodian of the corporate records and of the seal of the ApHC and see that the seal of the ApHC is affixed to all documents, the execution of which on behalf of the ApHC under its seal is duly authorized in accordance with the provisions of these Bylaws; keep a register of the post office address of each member which shall be furnished to the Chief Executive Officer by such members; and in general perform all duties incident to operations of the ApHC, the office of Chief Executive Officer and such other duties as may from time to time be prescribed by the Board of Directors.

Section 8. Treasurer. The Treasurer shall keep or cause to be kept, correct and complete records of accounts showing the financial condition and results of operations of the ApHC, shall be responsible for the preparation of an annual budget and shall report thereon to the Board of Directors. The Treasurer shall be legal custodian of all monies, notes, securities, and other valuables which may from time to time come into the possession of the ApHC. The Treasurer shall deposit all funds of the ApHC coming into the Treasurer's hands in depositories, to be designated by the Board of Directors. The Treasurer shall perform such other duties as may from time to time be prescribed by the Board of Directors.

ARTICLE VI

Committees

Section 1. Committees of Directors. The Board of Directors, by a resolution adopted by a majority of the directors in office, may designate and appoint one or more committees each of which shall consist of two or more directors, which committees, to the extent provided in said resolution shall have and exercise the authority of the Board of Directors in the management of the ApHC, except that no such committee shall have the authority of the Board of Directors in reference to amending, altering or repealing the Bylaws; electing, appointing or removing any member of any such committee or any director or officer of the ApHC; amending or restating the Articles of Incorporation; adopting a plan of merger or adopting a plan of consolidation with another corporation; authorizing the sale, lease, exchange or mortgage of all or substantially all of the property and assets of the ApHC; authorizing the voluntary dissolution of the ApHC; or revoking proceedings therefore; adopting a plan for the distribution of the assets of the ApHC; or amending, altering or repealing any resolutions of the Board of Directors which by its terms provides that it shall not be amended, altered or repealed by such committee. The designation and appointment of any such committee and the delegation thereto of authority shall not operate to relieve the Board of Directors, or any individual director of any responsibility imposed upon it or the director by law.

Section 2. Other Committees. Other committees not having and exercising the authority of the Board of Directors in the management of the ApHC may be appointed in such manner as may be designated by a resolution adopted by a majority of the directors present at a meeting at which a quorum is present. Except as otherwise provided in such resolution, members of each such committee shall be members of the ApHC, and the President shall appoint the members thereof. Any member thereof

may be removed by the person or persons authorized to appoint such member whenever in their judgment the best interest of the ApHC shall be served by such removal.

Section 3. ApHC Executive Committee. There shall be an ApHC Executive Committee, comprised of members of the Board of Directors, which shall consist of the President, who shall chair the ApHC Executive Committee, the Vice-President, and four (4) additional directors who shall be elected annually at the commencement of the regular meeting of the Board of Directors next held following the regular election of directors at a time and date during January through April as determined by the Board of Directors and shall serve on the ApHC Executive Committee until the election of the ApHC Executive Committee members at the commencement of said regular meeting of the Board of Directors the next year.

Section 4. Term of Office. Each member of a committee shall continue as such until the commencement of the regular meeting of the Board of Directors next held following the regular election of directors at a time and date during January through April as determined by the Board of Directors and until such member's successor is appointed, unless the committee shall be sooner terminated, unless such member be removed from such committee, or unless such member shall cease to qualify as a member thereof.

Section 5. Chairman. One member of each committee shall be appointed chairman by the person or persons authorized to appoint the members thereof.

Section 6. Vacancies. Vacancies in the membership of any committee may be filled by appointments made in the same manner as provided in the case of the original appointments.

Section 7. Quorum and Attendance at Meetings. Unless otherwise provided in the resolutions of the Board of Directors designating a committee, a majority of the whole committee shall constitute a quorum and the act of a majority of the members present at a meeting at which a quorum is present shall be the act of the committee. The Executive Committee of the ApHC Board of Directors, the ApHC Board of Directors or the Chairman of the ApHC committee conducting an ApHC committee meeting may conduct any such ApHC committee meeting and permit all such committee members to participate in such committee meeting through the use of any means of communication by which all such committee members participating may simultaneously hear each other during any such meeting. A committee member participating by any such means is deemed to be in attendance and present at any such meeting for all purposes under these Bylaws.

Section 8. Rules. Each committee may adopt rules for its own government not inconsistent with these Bylaws or the rules adopted by the Board of Directors.

ARTICLE VII

Indemnification

The ApHC shall indemnify to the fullest extent permitted by the Oregon Nonprofit Corporation Law any person who is made, or threatened to be made, a party to an action, suit or proceeding, whether civil, criminal, administrative, investigative or otherwise (including an action by or in the name of the ApHC), by reason of the fact that the person is or was a director or officer of the ApHC or serves or served at the request of the ApHC as a director or officer of any other corporation. The entitlement of any person to indemnification hereunder and the amount of that indemnification shall be determined in accordance with the procedures and other provisions set forth in the Oregon Nonprofit Corporation Law in effect at the time of the determination.

ARTICLE VIII

Contracts, Checks, Deposits and Funds

Section 1. Contracts. The Board of Directors may, by the affirmative vote of two-thirds of the directors present at a duly constituted meeting, authorize any officer or officers, agent or agents of the ApHC, in addition to the officers so authorized by these Bylaws, to enter into any contract or execute and deliver any instrument in the name of and on behalf of the ApHC and such authority may be general or confined to special instances.

Section 2. Checks, Drafts, etc. All checks, drafts or orders for the payment of money, notes of other evidences of indebtedness issued in the name of the ApHC shall be signed by such officer or officers, agent or agents of the ApHC and in such manner as shall from time to time be determined by resolution of the Board of Directors. In the absence of such determination by the Board of Directors, such instruments shall be signed by the Chief Executive Officer and countersigned by the President or Vice President.

Section 3. Deposits. All funds of the ApHC shall be deposited from time to time to the credit of the ApHC in such banks, trust companies or other depositories as the Board of Directors may select.

Section 4. Gifts. The Board of Directors may accept on behalf of the ApHC a contribution, gift, bequest or devise for the general purposes or for any special purpose of the ApHC.

ARTICLE IX

Certificates of Membership

Section 1. Certificates of Membership. The Board of Directors may provide for the issuance of certificates evidencing membership in the ApHC, which shall be in such form as may be determined by the Board. Such certificates shall be signed by the President or the Vice President and by the Chief Executive Officer or an Assistant Secretary and shall be sealed with the seal of the ApHC. All certificates evidencing membership of any class shall be consecutively numbered. The name and address of each member and the date of issuance of the certificate shall be entered on the records of the ApHC. If any certificate shall become lost, mutilated or destroyed, a new certificate may be issued therefore upon such terms and conditions as the Board of Directors may determine.

Section 2. Issuance of Certificates. When a member has been elected to membership and has paid any initiation fee and dues that may then be required, a certificate of membership shall be issued in the member's name and delivered to the member by the Chief Executive Officer, if the Board of Directors shall have provided for the issuance of certificates of membership under the provisions of Section 1 of this Article IX.

ARTICLE X

Books and Records

The ApHC shall keep correct and complete books and records of account and shall also keep minutes of the proceedings of its members, Board of Directors and committees having any of the authority of the Board of Directors, and shall keep at its registered principal office in the State of Oregon a record giving the names and addresses of the members entitled to vote. All books and records of the ApHC may be inspected by any member, or the member's agent or attorney, for any proper purpose at any reasonable time.

ARTICLE XI

Fiscal Year

The fiscal year of the ApHC shall begin on the first day of April and end on the last day of March in each year.

ARTICLE XII

Dues

Section 1. Annual Dues. The Board of Directors may determine from time to time the amount of initiation fee, if any, and the annual dues payable to the ApHC by members of each class.

Section 2. Payment of Dues. Dues shall be accrued and payable on the dates fixed by the Board of Directors.

Section 3. Default in Payment of Dues. When any member of any class shall be in default in the payment of dues for a period of 30 days from the date fixed by the Board of Directors for the payment of such dues, the member shall thereupon be deemed an inactive member and shall not be entitled to the privileges and rights of an active member. Such inactive member shall be reinstated as an active member with full privileges and rights immediately upon payment of the full amount due.

ARTICLE XIII

Seal

The Board of Directors shall maintain a corporate seal.

ARTICLE XIV

Waiver of Notice

Whenever any notice is required to be given under the provisions of the Oregon Nonprofit Corporation Law or under the provisions of the Restated Articles of Incorporation or Bylaws of the ApHC, waiver thereof in writing signed by the person or persons entitled to such notice, whether before or after the date stated therein, shall be deemed equivalent to the giving of such notice.

ARTICLE XV

Amendments to Bylaws

These Bylaws may be altered, amended or repealed and new Bylaws may be adopted in accordance with the procedures and provisions of the Oregon Nonprofit Corporation Law by 1) **the affirmative vote of at least two-thirds (2/3) of all elected and appointed directors made at a regular meeting of the ApHC Board of Directors** or, 2) at a duly constituted annual meeting of members by an affirmative vote of at least two-thirds of the members present at the meeting; provided, however, that notice of any proposed change shall have been given under the provisions of Oregon Nonprofit Corporation Law and, further provided, however, that any proposed change shall thereafter be submitted to a vote of the members of the ApHC entitled to vote on Bylaws by means of a ballot provided according to voting procedures permitted by the Oregon Nonprofit Corporation Law and determined from time to time by the ApHC Board of Directors and shall not be effective unless approved by at least two-thirds of the votes cast.

RULES AND REGULATIONS

The rules and regulations contained in this *Official Handbook* of the Appaloosa Horse Club are in full force and effect beginning **January 1, 2013** Rules and regulations contained in any Appaloosa Horse Club *Official Handbook* published before **January 1, 2013** are hereby repealed. Rules 1-9 are not assigned.

10. MEMBERSHIP

A. CLASSES

Membership in the ApHC is a privilege, not a right. ApHC bylaws provide for two classes of members: regular members and honorary life members.

B. REGULAR

Regular membership is divided into:

1. Individual Lifetime Class: Valid for the lifetime of the individual.
2. Youth One-time Class: The Youth one-time membership is valid for the entire calendar year in which the youth is 18 years of age and under as of January 1 of each year. (Age to be retained throughout the calendar year.) Married or divorced individuals are ineligible for membership in the Appaloosa Youth Association. This is a non voting membership.
3. Classes where membership is annually approved with eligibility being determined based upon the following:
 - a. Individual. One Person
 - b. Married Couple. Each spouse is considered a member and will be assigned a membership number.
 - c. Family. The head of household, spouse, if any, and individuals 18 years of age and under as of January 1 of each year. Each head of household or spouse, if any, in the family is considered a member and will be assigned a membership number. Each individual in the family 18 years of age and under as of January 1 of each year will be given a non-voting Appaloosa Youth Association (AYA) membership.
 - d. Appaloosa Youth Association (AYA) Youth. An individual 18 years of age and under as of January 1 of each year. (Age to be retained throughout the calendar year.) Married or divorced individuals are ineligible for membership in the Appaloosa Youth Association. This is a non-voting membership.
 - e. Non-Pro. An individual 19 years of age or older as of January 1 of each year or a married individual ineligible for membership in the Appaloosa Youth Association who is also a member of the ApHC. Additional Non-Pro eligibility criteria are set forth in the Non-Pro section of these rules.
 - f. Limited Participation Membership. An individual 19 years of age as of January 1st of each year may participate in an ApHC-sponsored or -approved activity on a per event basis by purchasing a limited participation membership on the day of an event which is valid for use only at that ApHC-approved or -sponsored event at which it is purchased, provided, however, a limited participation membership is not valid for the ApHC National Show, ApHC World Show, and the Chief Joseph Trail Ride and is not valid for showing in non-pro classes, which requires a regular membership per Rule 900.A. This type of membership is non-voting and will not receive *Appaloosa Journal*. The limited participation membership does not include reduced fees for filing any documents pertaining to the ApHC registration or transfer process or any other ApHC related documents and is strictly limited to participation at the event at which it is purchased. Individual points or mileage will not be counted or retained by the ApHC.

C. EFFECT OF MEMBERSHIP

Every member, by making application to the ApHC for membership or renewal and in becoming a member or non-member, by purchasing registered Appaloosas, by filing registration applications or other documents with the ApHC or by participating in ApHC approved events, automatically agrees to be bound by and to abide by the Articles of Incorporation, bylaws, rules and regulations, decisions and policies of the ApHC, its Board of Directors, Chief Executive Officer, employees and authorized agents.

D. LEGAL ACTIONS

Every member and non-member agrees that he or she will not commence any action, whether in law or equity, against the ApHC in any courts other than those federal and state courts located in Latah County, Idaho, and further agrees, for the mutual benefit of members and nonmembers and to reduce the costs and legal expenses incurred by the ApHC which would otherwise be borne by members and nonmembers participating in ApHC activities, in addition to any other sanction that may be imposed under these rules, to reimburse the ApHC, upon demand by the ApHC, the reasonable attorney fees, costs and other expenses, including, but not limited to, travel related expenses for Disciplinary Committee members, incurred by the ApHC

in connection with any ApHC disciplinary action or proceeding, arbitration action or proceeding, court action or proceeding or other legal proceeding in which the member or nonmember has been determined to have violated any ApHC bylaws or rules and regulations or has not been the prevailing party.

E. APPLICATION

Application for membership shall be made by completing and submitting an application, on a form provided by the ApHC, and the current membership fee. To renew a membership, a member must annually complete and submit a membership renewal application, on a form provided by the ApHC, and the current membership fee. Membership is granted for the calendar year or such portion of the calendar year remaining after the application or renewal form has been submitted and, if applicable, approved. Being a member of an ApHC regional club does not, of itself, make an individual a member of the ApHC.

F. APPROVAL OR REJECTION

A membership application or renewal application shall be approved or rejected by the Chief Executive Officer in accordance with ApHC bylaws and these rules. A membership cannot be issued in a ranch, farm, company or business name. An application for ApHC membership or renewal may be rejected by the Chief Executive Officer if the applicant does not qualify to be an ApHC member, has been convicted of an animal welfare violation, has been convicted of a crime involving moral turpitude or is under suspension by another equine association.

G. PRIVILEGES

Each ApHC member's privileges include:

1. Equal rights and interests in conjunction with other members similarly qualified in and to ApHC events, programs, activities and property.
2. Subscription to *Appaloosa Journal* (excluding Youth Members).
3. Nomination and voting rights conferred by the Articles of Incorporation, bylaws and Oregon Nonprofit Corporation Law.
4. Right to be a candidate, if otherwise qualified, and if elected, hold office in the ApHC and serve on committees as appointed by the Board of Directors.
5. Reduced rates on many ApHC services.
6. Receipt of the *Official Handbook* of the ApHC.
7. Receipt of the annual audit and notice of annual meeting of members.
8. Receipt of an official membership card

H. TRANSFERABILITY AND NAME CHANGE

ApHC membership is not transferable and ApHC membership fees are not refundable. The name of a member may be changed in the membership records of the ApHC to reflect a legal change of name upon submission of appropriate documentation, such as a marriage license or court decree, as may be required by the ApHC.

I. RENEWAL DEADLINE

If any such member fails to renew membership by January 1 of each year, such individual shall automatically cease being a member as of January 1 of that year but can apply for reinstatement as a member thereafter for the remainder of that calendar year upon compliance with all membership renewal requirements and approval by the Chief Executive Officer.

J. TERMINATION

An individual's ApHC membership may be terminated by the ApHC for cause for conduct by such individual detrimental to the interests of the ApHC, its programs, policies, objectives and harmonious relationship of its members. Membership termination proceedings hereunder shall be initiated by written complaint, shall be conducted pursuant to the ApHC's hearing procedures set forth under these rules and shall subject the accused member to all penalties called for under these rules, including suspension or termination of membership.

11. INFORMATION RELEASE POLICY

- A. Certain information about ApHC members or work may be confidential. The ApHC will not disclose sensitive or legal matters, hearing results, Executive Committee meetings or any legal actions taken by the ApHC, unless the ApHC elects to disclose such information, including publication in *Appaloosa Journal*.
- B. Information that may be released without written consent of the owner or other affected person includes:
1. any horse's performance records as available including points, awards and earnings;
 2. any horse's produce records, including but not limited to color production records;
 3. any horse's pedigree;
 4. the name of any current or past owners of any horse;
 5. the address or last known address of any member or non-member contained in ApHC customer files; and
 6. the membership status of any individual.
- C. Information that may not be released without written consent of the owner or other affected person includes:
1. stallion reports;
 2. breeders' certificates;
 3. number or names of horses owned;
 4. registration application material;
 5. any customer's phone number unless previously or currently published in *Appaloosa Journal*; or
 6. any financial information pertaining to a customer's account balance or NSF check.
- D. The ApHC may disclose any information in its possession if compelled to do so by properly issued court order or subpoena or for any other proper corporate purpose.

Rules 12-14 are not assigned.

15. GENERAL NOTICE PROCEDURE

Any notice required by these rules shall be given by personal delivery or by regular United States mail to the person who is to receive the notice, or the person's counsel. If mailed, notice shall be deemed to be given when deposited in the United States mail addressed to the person at the person's most recent address as it appears in the records of the ApHC, or to the counsel at the counsel's address, with postage thereon prepaid, unless otherwise provided in these rules or in the documents prepared by the ApHC.

Rules 16-19 are not assigned.

20. DISCIPLINARY PROCEDURE

A. CAUSE

Whenever any member or non-member has violated any bylaw, rule or regulation, decision or policy of the ApHC, any such member may be disciplined, suspended, or expelled, any such member or non-member may be fined and denied any or all of the privileges and rights of the ApHC and any Certificate of Registration may be cancelled or modified or registration application denied.

B. TEMPORARY SUSPENSION WITHOUT HEARING

The Chief Executive Officer may temporarily suspend, without hearing, any member and may temporarily deny the privileges and rights of the ApHC to any non-member for the periods set forth below for (1) failure to pay any obligation (other than dues) owing to the ApHC or to *Appaloosa Journal*, (2) giving a non-sufficient funds check in payment of entry fees, stall fees, office charges, stock charges, purchases or any other fee or charge connected with the exhibition of horses at any approved,

sponsored or authorized ApHC function or race event or connected with the inspection of any horse, or (3) failure to complete and file a required and accurate annual stallion breeding report with the ApHC, (4) failure to file required DNA test results, (5) failure to list a stallion or mare registered with an approved breed association, or (6) failure to return to the ApHC upon written request any Certificate of Registration for revocation, correction or other appropriate action, provided that written notice of the intention to suspend or withhold privileges and rights was mailed to the member or non member not less than 15 days prior to the effective date of such action. Any suspension made by the Chief Executive Officer pursuant to this rule shall continue until 1) payment of the full amount due, 2) filing of the requisite stallion breeding report, listing of the stallion or mare, or DNA test results or 3) return of any Certificate of Registration. Any member suspended a second time pursuant to this rule shall be suspended for a minimum period of ninety (90) days and such suspension shall continue thereafter until compliance has occurred as required above. Any member suspended a third time pursuant to this rule shall be expelled from membership and shall not again be eligible to be a member of the ApHC.

C. DISCIPLINARY COMMITTEE JURISDICTION

Except for those matters that are within the jurisdiction of the Chief Executive Officer or are expressly delegated by these rules to another person or committee, the Disciplinary Committee is the forum within the ApHC which shall hear or review evidence of alleged violations of ApHC bylaws, rules or regulations, decisions or policies by members or non-members and which shall have jurisdiction to invoke penalties and sanctions as provided under these rules. The Disciplinary Committee is a committee of the whole with a requirement that there must be a quorum of five (5) disinterested directors to hear any matter.

D. COMPLAINT

A complaint of possible or alleged violation(s) by a member or non-member of any bylaw, rule or regulation, decision or policy of the ApHC must be processed as follows:

1. A written complaint, which must be dated and signed, must be submitted by a member, ApHC director or ApHC employee, to the ApHC Chief Executive Officer and/or the ApHC President, and state the specific bylaw, rule or regulation, decision or policy alleged to have been violated and the person(s) allegedly responsible for such violation(s). Any member filing a complaint, except ApHC directors or employees acting in that capacity, shall be required to pay a filing fee of \$250 to defer costs of hearing.
2. The complaint must set forth prima facie evidence in support of any allegation. The individual(s) filing the complaint will be required to present testimony and/or evidence at a hearing, if a hearing is deemed necessary by the ApHC, or the complaint may be dismissed by the Disciplinary Committee.
3. The ApHC Chief Executive Officer and the ApHC President will have the authority, but are not required, to investigate the allegations of a complaint. Full disclosure of the complaint will be made to the person(s) charged with such violation(s) prior to any disciplinary action. In the case of a complaint involving a youth member, either as complainant or person charged, an investigation must take place, and the evidence be reviewed by the ApHC CEO, the ApHC President or the ApHC Vice-President.
4. A majority of the Chief Executive Officer, ApHC President and ApHC Vice President, with advice from ApHC legal counsel, shall determine if prima facie evidence has been presented in the complaint sufficient to warrant a hearing before the Disciplinary Committee. If such prima facie evidence has not been so presented, the complaint will be dismissed. The Chief Executive Officer, the ApHC President and the ApHC Vice President may agree to assess against the person filing the complaint costs, including attorney fees, incurred by the ApHC in reviewing any frivolous or unfounded complaint. Complainant will be so notified but shall have a right to resubmit the complaint with new or additional evidence up to ninety (90) days from the date of the dismissal of the original complaint otherwise complainant will have no right to resubmit the complaint.

5. If it is determined that sufficient prima facie evidence has been presented, the Chief Executive Officer will cause notice of the hearing to be given to the charged member or nonmember as provided in rule 20.E.1. In such cases involving alleged violation(s) of any ApHC rule(s) pertaining to administration of a forbidden substance, notice of hearing shall be given and the hearing shall occur as close to 30 days after notice is given as is possible under the circumstances. Either the Disciplinary Committee or the Chief Executive Officer, upon instruction by the Disciplinary Committee, is authorized to issue the Disciplinary Committee's written decision by notice to the parties.
 - a. If two or more complaints are filed concerning the same incident, prima facie evidence presented by the complaining parties may be reviewed in order to determine the validity of any such complaints and the hearing(s) related to any such complaints may, at the ApHC's discretion, occur simultaneously.
6. The Chief Executive Officer, with approval from ApHC Executive Committee, shall have the authority of the Disciplinary Committee to enter into an appropriate agreement, including the imposition of sanctions and penalties called for under these rules, in the best interests of the ApHC settling and/or compromising and satisfying a complaint before any such complaint is heard by the Disciplinary Committee.
7. The Executive Committee or the Disciplinary Committee shall have authority to enter into an appropriate agreement at any stage of these proceedings, in the best interests of the ApHC, settling and/or compromising and satisfying the complaint. A complainant may withdraw a complaint at any time, forfeiting all fees and costs for the complaint, and may also be subject to assessment of the costs of hearing the complaint, including attorney fees in reviewing any frivolous or unfounded complaint.
8. Any agreement entered into under Rules 20.D.6. & 20.D.7. shall not be binding and effective until executed by Chief Executive Officer, the ApHC President on behalf of the Executive Committee, and all affected parties.

E. HEARING PROCEDURES

1. Written notice of the date, time and location of a hearing, together with a description of the violation charged and accompanying statement of evidence shall be mailed to the charged member or non-member not less than thirty (30) days prior to the hearing.
2. All disciplinary hearings will be held at the offices of the ApHC in Moscow, Idaho or as specified by the Disciplinary Committee. Any person participating in a hearing, including Disciplinary Committee members, persons charged, counsel and witnesses may appear at the hearing in person by way of teleconferencing. Any person appearing by teleconferencing shall notify the Chief Executive Officer in writing at least ten (10) days before the hearing and include a telephone number at which they can be reached at the time set for hearing.
3. Any interested person may submit a written, verified statement to the Disciplinary Committee prior to the hearing that shall be made part of the hearing record.
4. No continuance will be granted unless requested in writing and received in the ApHC office at least ten (10) days before the hearing and good cause is shown. A continuance will be granted or denied at the sole discretion of the President.
5. The member or non-member charged by the complaint and the Complainant shall have the right to call witnesses, present testimony, under oath, and offer evidence, to cross examine any adverse witnesses and to provide rebuttal testimony and evidence.
6. The ApHC reserves the right to appear in any hearing, through designees and/or counsel, and call witnesses, present testimony, under oath, and offer other evidence, to cross examine any other witnesses and to provide rebuttal testimony and evidence.
7. The Disciplinary Committee may call and interrogate witnesses.

F. HEARING STANDARDS

1. Proceedings before the Disciplinary Committee shall be informal, and rules of evidence, both at common law or provided by Idaho rules of civil or criminal

evidence or procedure, need not be strictly observed. The standard by which admissibility is determined is whether the evidence is such that an ordinarily prudent person is willing to rely upon it. The Disciplinary Committee will be the sole judge of the relevance and probative value attributed to any evidence.

2. Proof necessary to establish a rule violation is that quantum of proof which would lead a reasonable person to believe the matter alleged in the complaint and notice of hearing is established by the evidence presented to the Disciplinary Committee.
3. A majority vote of the Disciplinary Committee hearing any matter shall be determinative of guilt, and its decision and action shall be final and binding on all parties, except that the Disciplinary Committee reserves the right to modify or set aside its decision for reasons of mistake, fraud or misrepresentation or any other reason justifying relief from a decision.
4. All parties, witnesses and participants in a disciplinary process, including members of the Disciplinary Committee, shall be immune from any civil liability whatever, including, but not limited to, libel, slander, invasion of privacy, defamation, product disparagement, interference with contract, interference with prospective business relations and any other tortious conduct, for testimony given and/or evidence presented in connection with the proceeding or at the hearing.

G. ALTERNATIVE HEARING PROCEDURE

1. In the event the Disciplinary Committee, in its sole judgment, is unable or refuses to hear any matter, every member or non-member agrees to submit to hearing and determination of any alleged violation of ApHC rules before and under jurisdiction of the American Arbitration Association, which shall apply ApHC rules and regulations pertaining to violations and penalties and shall apply the procedural rules of the American Arbitration Association.
2. All expenses associated with employment of the American Arbitration Association shall be paid, in advance, by the member(s) initiating or alleging any such charge of rule violation or, if not so paid, any such charge of rule violation shall be summarily dismissed by the ApHC.
3. The American Arbitration Association's decision shall be determinative of guilt and its decision and action shall be final and binding on all parties and the ApHC.

H. DISCIPLINARY RECIPROCALITY

1. The ApHC may give reciprocal effect to the authorized disciplinary action of any association listed in subsection 3 of this rule for misconduct involving any horse including, but not limited to, the following categories of misconduct:
 - a. Unsportsmanlike conduct.
 - b. Cruel or inhumane treatment of horses.
 - c. Prohibited surgical procedure or injection or administration of foreign substances, drugs or medication that could affect a horse's performance, soundness or disposition or alter its natural conformation or appearance.
2. If an individual is convicted of or pleads guilty to or is found to have participated knowingly in any such misconduct under state or federal law or rules of other equine associations, such conviction, plea or finding shall create a presumption of violation of ApHC rules.
3. The ApHC will consider giving reciprocal effect to the authorized disciplinary action of the following associations:
 - a. International Affiliates of the Appaloosa Horse Club
 - b. American Miniature Horse Association (AMHA)
 - c. American Paint Horse Association (APHA)
 - d. American Quarter Horse Association (AQHA)
 - e. International Buckskin Horse Association (IBHA)
 - f. National Cutting Horse Association (NCHA)
 - g. National Reining Horse Association (NRHA)
 - h. National Snaffle Bit Association (NSBA)
 - i. Palomino Horse Breeders of America (PHBA)
 - j. Pinto Horse Association of America (PtHA)
 - k. Pony of the Americas Clubs (POA)
1. Any other horse breed association or equine organization that the ApHC deems to be reputable and responsible.

4. A complaint alleging that an ApHC member or nonmember should be subject to reciprocal effect for any such misconduct shall be processed and heard by the ApHC Disciplinary Committee in like manner as disciplinary procedures for violation of ApHC rules.
5. Any ApHC member or nonmember against whom reciprocal effect is given by the ApHC for any such misconduct is subject to those penalties set forth in GENERAL PENALTIES AND SANCTIONS.
6. The ApHC shall promptly notify each association listed in rule 20.H.3 with the name of and violation committed by each individual who either pleads guilty or is convicted after hearing of violations of ApHC rules pertaining to those categories of misconduct listed in 20.H.1.

Rules 21-29 are not assigned.

30. GENERAL VIOLATIONS

Violation of any ApHC rule and/or regulations will subject the ApHC member and/or nonmember to disciplinary procedures and, if found guilty, those penalties and sanctions called for under these rules. Violations by an ApHC member and/or nonmember, as the case may be, include, but are not limited to, those set forth under this rule.

A. CRUEL AND INHUMANE TREATMENT

1. No person may treat a horse in an inhumane manner, which includes but is not limited to:
 - a. Placing an object in a horse's mouth so as to cause undue discomfort or distress.
 - b. Tying a horse in a manner as to cause undue discomfort or distress including but not limited to in a stall, trailer or when longeing or riding.
 - c. Letting blood from a horse.
 - d. Using of inhumane training techniques, equipment or methods including but not limited to poling or striking horse's legs with objects (i.e. tack poles, jump poles, etc.).
 - e. Attaching any item or appliance that restricts movement or circulation of the tail.
 - f. Inhumane treatment that causes a horse to bleed.
 - g. Use of inhumane equipment including, but not limited to sawtooth bits, hock hobbles, tack collars or tack hackamores.
 - h. Any surgical procedure or injection of any foreign substance or drug which could affect the horse's performance or alter its natural conformation or appearance is prohibited, except for those surgical procedures performed for the sole purpose of protecting the health of the horse. See DRUGS AND MEDICATIONS and DEVICES AND APPLIANCES for complete rules.
 - i. Exhibiting a horse that appears to be sullen, dull, lethargic, emaciated, drawn or overly tired.
 - j. Exhibiting a horse that has an open, raw or bleeding sore that repeatedly comes in contact with the hackamore.
 - k. Withholding food and/or water for prolonged periods of time such that it causes undue discomfort or distress to the horse.
2. The standard by which conduct or treatment will be measured is that which a reasonable person, informed and experienced in generally accepted equine training and exhibition procedures, would determine to be cruel, abusive and inhumane.
3. This prohibition includes all horses, not just Appaloosa horses, as such conduct indicates a general treatment of horses that is unacceptable for ApHC members. If an individual is convicted or found to have participated knowingly under state or federal law or rules of other equine breed associations in cruel or inhumane treatment of a horse, such conviction or finding shall create a presumption of violation of this rule.
4. Upon discovery by a show official of inhumane treatment, show management shall immediately report the matter to the ApHC.

5. Pending final hearing by the Disciplinary Committee, the Chief Executive Officer may, by giving written notice of his action to the owner of record at his/her current address as evidenced by ApHC records, temporarily suspend a horse and/or any responsible party as defined in RESPONSIBLE PARTY from further participation in ApHC-approved or sponsored events or shows.
 - a. The Chief Executive Officer may secure the opinion of a licensed veterinarian or other appropriate professional to aid in the determination of violation of this rule.

B. FRAUDULENT PRACTICES

Knowingly misrepresenting any material fact pertaining to a horse, ApHC document, of a matter of significance to the interests of the ApHC, its programs, policies and objectives, including, but not limited to:

1. Representing any horse as an ApHC registered horse that is not an ApHC registered horse or representing that an ApHC registered horse has a classification that such horse does not have or that has been revoked or changed.
2. Providing false information to the ApHC or any person regarding the name, age, parentage, or registration status of a horse.
3. Representing that a horse registered with the ApHC has earned or is entitled to any official ApHC designation, honor, points and/or awards that such horse has not either earned or received or prior to the actual issuance of such designation, honor, points and/or awards or after the ApHC has cancelled said designation, honor, points and/or awards.
4. Representing a certificate or other document as valid and issued or prepared or altered by the ApHC that was not valid and issued or prepared or altered by the ApHC.
5. Committing forgery or providing false information on or with respect to any document filed with the ApHC or altering any official ApHC document.
6. Representing a horse as bearing natural characteristic(s) and/or coat pattern that actually bears artificial characteristic(s) and/or artificial coat pattern.
7. Altering, changing or attempting to hide or alter natural markings of a horse by surgery, dye or any other manner or coloring of the hooves to hide or cover natural characteristics of the hooves or hoof (clear hoof dressing being expressly allowed) or the use of a substance of any color on the hooves or hoof.
8. Falsely representing oneself as an ApHC official, director, employee, judge, or steward through verbal, written or electronic communication.

C. ABUSE OF ApHC OFFICIALS

Engaging in abusive, intimidating or threatening conduct toward any Director, Officer, staff member, employee of the ApHC or show personnel while in furtherance of their official duties or engage in conduct detrimental to the legitimate business interest of the ApHC.

D. NON-COMPLIANCE

1. Failing or refusing to permit examination of a horse, in competition or not, by a licensed veterinarian or his/her agent upon request of any ApHC representative for the purpose of determining whether a violation of rules has occurred.
 - a. All horses in competition in an ApHC-approved or -sponsored event are subject to examination by such veterinarian or his/her agent appointed for that purpose by the ApHC. Said appointed veterinarian, with the approval of the ApHC, may appoint technicians to perform certain duties under this rule. The examination may include physical, saliva, urine, or blood tests or any other test or procedure at the discretion of said veterinarian necessary to effectuate the purposes of this rule. Said veterinarian may examine any or all horses in a class or all classes in an event or any horse entered in any class, whether in competition or not if on the show grounds, or any horse withdrawn by an exhibitor within 24 hours prior to a class for which it has been entered, unless otherwise directed by the ApHC. Any such violation subjects all responsible parties to disciplinary action.

2. Failing to comply with or abide by penalties, sanctions, restrictions and/or conditions imposed as a result of disciplinary action taken by the ApHC or failing to comply with or abide by any request made by any ApHC employee for the return or delivery of any Certificate of Registration or other documentation as required by these rules.

E. REFUSING TO PROVIDE INFORMATION

Refusing any reasonable request by the ApHC, its officers, committees, or agents for assistance in locating, identifying, inspecting, examining, cooperating with any testing and/or identification procedures, providing certificates of registration, obtaining information, and/or answering promptly and truthfully any inquiry concerning a horse which the person owned, was the owner of or had control of the sire or the dam of (a) which has been registered, or identified, or listed on any report filed with the ApHC, (b) for which a registration application or listing on any report has been filed with the ApHC, or (c) which is alleged to be an ancestor of a registered horse, or identified horse, or horse listed on any report filed with the ApHC, or horse to be registered.

F. CONSPIRACY

Conspiring or knowingly cooperating or contributing, either by inaction or action, to violate intentionally, heedlessly or recklessly, any ApHC rule.

Rules 31-39 are not assigned.

40. DRUGS AND MEDICATIONS

A. CAUTION

Exhibitors, owners, trainers and veterinarians are cautioned against the use of medicinal preparations, tonics, pastes, and products of any kind, the ingredients and quantitative analysis of which are not specifically known, as many of them may contain a forbidden substance.

B. NO FORBIDDEN SUBSTANCE

No horse shall be shown in any class in any ApHC-approved or -sponsored event or race meet or meet or event held in conjunction with an ApHC-approved or -sponsored event or race meet if, either before or during such approved or sponsored event, the horse has been administered in any manner any forbidden substance.

C. DEFINITION OF FORBIDDEN SUBSTANCE

For purposes of these rules, a forbidden substance is any:

1. Stimulant, depressant, tranquilizer, local anesthetic, psychotropic (mood and/or behavior altering) substance, or drug that might affect the performance of a horse (stimulants and /or depressants are defined as substances that stimulate or depress the cardiovascular, respiratory or central nervous system), or any metabolite and/ or analogue of any such substance or drug, except as expressly permitted by this rule. Drugs, medications and pharmaceutical products are classified for purposes of ApHC rules in accordance with the most current published edition of the Association of Racing Commissioners International, Inc. (ARCI) Uniform Classification Guidelines for Foreign Substances.
2. Anabolic steroid, testosterone or testosterone analog substance.
3. Substance permitted by this rule in excess of the maximum limit for such substance set forth in this rule.
4. Substance, regardless of how harmless or innocuous it might be, that may interfere with ApHC's drug testing procedures or interfere with the detection of any forbidden substance or quantification of substances permitted by this rule.

D. PERMITTED EXCEPTIONS

Certain therapeutic and non-optional medications are permitted to be administered to a horse shown in an ApHC-approved or -sponsored event only under the following conditions:

1. The medication must be therapeutic and necessary for the diagnosis or treatment of an existing documented illness or injury of the horse. Administration of a forbidden substance for non-therapeutic or optional purposes (such as, by way of

example only, transporting, shipping, clipping, training, turning out, routine floating or cleaning of teeth, nondiagnostic nerve blocking, uncasting, mane pulling or non-emergency shoeing) is not considered to be therapeutic or non-optional.

2. The only conditionally permitted medications that may be administered within 24 hours of a horse's participation in any class are:

Phenylbutazone, Diclofenac (Surpass), Flunixin, Ketoprofen, Meclofenamic Acid, Naproxen, Dexamethasone, Firocoxib (Equioxx), Acetazolamide, Furosemide and Lidocaine/Mepivacaine, and then only under the conditions as set forth in this rule and within the following concentrations. No more than one of the above NSAID medications can exceed maximum acceptable trace plasma levels and no more than two of the above conditionally permitted NSAID medications can be present together in the horse's system. The use of more than one NSAID medication within a 48- hour period is not permitted.

3. **CAUTION**—Exhibitors, owners, trainers and veterinarians are cautioned against the use of medicinal preparations, tonics, pastes, and products of any kind, the ingredients and quantitative analysis of which are not specifically known, as many of them may contain a forbidden substance.

4. The exception permitted by this rule for administration of conditionally permitted medications does not apply if administration of the medication is otherwise prohibited by applicable governmental law, rule or regulation.

NOTE TO RULE 40.C.—ADMINISTRATION GUIDELINES

The following administration guidelines are not to be considered as authorizing administration of medication to any horse in any quantity and shall not be deemed to modify this rule in any manner regarding maximum permissible concentration of any drugs. These guidelines do not guarantee compliance with this rule but are offered to assist responsible parties in complying with the requirements of this rule. Responsible parties are advised to consult a knowledgeable veterinarian. Reliance upon these guidelines will not serve as a defense to a charge of violation of ApHC rules regarding administration of forbidden substances.

1. The maximum allowable plasma concentration of phenylbutazone is 15.0 micrograms/ml and the maximum plasma concentration considered trace is 2.0 micrograms/ml. Whenever phenylbutazone is administered, the dose should be accurately calculated according to the actual weight of the horse. Each 24 hours, not more than 0.2 grams per 100 pounds body weight should be administered, preferably less. For a 1,000 pound animal, the maximum daily dose is 2.0 grams, which equals two one-gram tablets, or two one-gram units of paste, or 10 cc of the injectable, or the equivalent. No dose should be administered during the 24 hours immediately following the prior dose. No part of a dose should be administered during the twelve (12) hours prior to competing. If the medication is administered in the feed, the medicated feed should be removed not closer than twelve (12) hours prior to competing, although the horse may be given unmedicated feed any time. The medication should be used for not more than five (5) successive days.
2. The maximum allowable plasma concentration of Flunixin is 1.0 microgram/ml and the maximum plasma concentration of Flunixin considered trace is 0.2 micrograms/ml. Whenever flunixin is administered, the doses should be accurately calculated according to the actual weight of the horse. Each 24 hours, not more than 50.0 milligrams per 100 pounds body weight should be administered, preferably less. For a 1,000 pound animal, the maximum daily dose is 500 mg, which equals one 500 mg unit of paste, or one 500 mg packet of granules, or two 250 mg packets of granules, or 10 cc of the injectable, or the equivalent. No dose should be administered during the 24 hours immediately following the prior dose. No part of a dose should be administered during the twelve (12) hours prior to competing. If the medication is administered in the feed, the medicated feed should be removed not closer than twelve (12) hours prior to competing, although the horse may be given unmedicated feed any time. The medication should not be used for more than five (5) successive days.

3. Diclofenac (Surpass)—The maximum allowable plasma concentration of Diclofenac is 5 nanograms/ml and the maximum plasma concentration considered trace is 1 nanogram/ml. Every 12 hours, not more than 73 mg of diclofenac liposomal cream should be administered (not more than 146 mg per 24 hour period) to one affected site. This 73 mg dose equals a five-inch ribbon of cream not greater than one-half inch in width, which should be rubbed thoroughly into the hair over the joint or affected site using gloved hands. Administration of diclofenac cream should be discontinued twelve (12) hours prior to competing. Do not apply diclofenac cream in combination with any other topical preparations including DMSO, nitrofurazone or liniments, and do not use on an open wound. Diclofenac cream should not be administered for more than 10 successive days. Use the topical preparation only, not the oral alternative. Follow the manufacturer's directions specifically.
4. Ketoprofen—The maximum permitted plasma concentration of Ketoprofen is 40.0 nanograms per milliliter, and the maximum permitted trace level is 10.0 nanograms per milliliter. When Ketoprofen (Ketofen[®]) is administered, the dose should be accurately calculated according to the actual weight of the animal. Each 24 hours, not more than 1.0 milligram per pound of body weight should be administered. For a 1,000-pound animal, the maximum daily dose is 1.0 gram, which equals 10 cc of the injectable (100 milligrams per milliliter). No part of a dose should be administered during the twelve (12) hours prior to competing. The medication should not be used for more than five successive days.
5. Meclofenamic Acid—The maximum permitted plasma concentration of Meclofenamic Acid (Arquel[®]) is 2.5 micrograms per milliliter, and the maximum permitted trace level is 0.1 micrograms per milliliter. When Meclofenamic Acid is administered, the dose should be accurately calculated according to the actual weight of the animal. Each twelve (12) hours, not more than 0.5 milligram per pound of body weight should be administered, preferably less. For a 1,000-pound animal, the maximum 12-hour dose is 0.5 gram, which equals one 500-milligram packet of granules. The medication should not be used for more than five successive days.
6. Naproxen—The maximum permitted plasma concentration of Naproxen is 40.0 micrograms per milliliter, and the maximum permitted trace level is 2.0 micrograms per milliliter. When Naproxen is administered, the dose should be accurately calculated according to the actual weight of the animal. Each 24 hours, not more than 4.0 milligrams per pound of body weight should be administered. For a 1,000-pound animal, the maximum daily dose is 4.0 grams, which equals eight 500-milligram tablets. No part of a dose should be administered during the twelve (12) hours prior to competing. Any medicated feed should be consumed and/or removed at least twelve (12) hours prior to competing. The medication should not be used for more than five successive days.
7. Acetazolamide—May only be administered to horses documented through DNA testing from a sample that has also been tested to verify parentage, to be positive (N/H or H/H) for HYPP (Hyperkalemic Periodic Paralysis) and such HYPP status must be noted on ApHC Certificate of Registration and made available to the public in the horse's files. When acetazolamide is administered, the dose should be accurately calculated according to the actual weight of the animal. Each 24 hours, not more than 3 milligrams per pound of body weight should be administered. For a 1,000-pound animal, the maximum daily dose is 3 grams. Owners must notify the ApHC of HYPP test results (N/H or H/H) and said notice shall be filed with the ApHC and include proper identification of the horse and such notification shall be required prior to administration of acetazolamide.
8. Furosemide or Lasix[®]—When used, must be administered intravenously at least four (4) hours prior to competition. The maximum permitted plasma concentration of furosemide is 100 nanograms per milliliter.
9. Lidocaine/Mepivacaine—(when administered within 24 hours of showing) may only be used under actual observation of event management (or designated

representative) and/or the official show veterinarian, either of whom must sign a medication report form, to aid in the surgical repair of minor skin lacerations which, by their very nature, would not prevent the horse from competing following surgery. Said medication report form must be filed with show management.

10. Dexamethasone—The maximum permitted plasma concentration is 3.0 nanograms per milliliter at the time of competition. In order to help trainers, owners and their veterinarians achieve compliance with this rule in connection with the therapeutic use of dexamethasone, it should be administered in accordance with the guidelines below. These guidelines include several alternative scenarios for dose time, and route of administration. Whenever dexamethasone is administered, the dose should be accurately calculated according to the actual weight of the animal.
 - a. Alternative number 1. (2.0 mg or less per 100 pounds IV or IM at twelve [12] or more hours before competition). Each 24 hours, not more than 2.0 milligrams of dexamethasone injectable solution per 100 pounds of body weight should be administered intravenously or intramuscularly, preferably less. For a 1,000-pound animal, the maximum daily intravenous or intramuscular dose of dexamethasone injectable solution is 20.0 milligrams, which equals 5.0 milliliters of the injectable solution (4.0 milligrams per milliliter). No part of this dose should be administered during the twelve (12) hours prior to competing. Dexamethasone should not be administered for more than five successive days.
 - b. Alternative number 2. (0.5 mg or less per 100 pounds IV at 6 or more hours before competition). Each 24 hours, not more than 0.5 milligrams of dexamethasone injectable solution per 100 pounds of body weight should be administered intravenously, preferably less. For a 1,000 pound animal, the maximum daily intravenous dose of dexamethasone injectable solution is 5.0 milligrams, which equals 1.25 milliliters of the injectable solution (4.0 milligrams per milliliter). No part of this dose should be administered during the six hours prior to competing. Dexamethasone should not be administered for more than five successive days.
 - c. Alternative number 3. (1.0 mg or less per 100 pounds orally at 6 or more hours before competition). Each 24 hours, not more than 1.0 milligram of dexamethasone powder per 100 pounds of body weight should be administered orally, preferably less. For a 1,000- pound animal, the maximum daily oral dose of dexamethasone powder is 10.0 milligrams, which equals one packet of dexamethasone powder (10.0 milligrams per packet). No part of this dose should be administered during the 6 hours prior to competing. Any medicated feed should be either consumed or removed at least six (6) hours prior to competing. Dexamethasone should not be administered for more than five successive days.
11. Firocoxib (Equioxx) – The maximum permitted plasma concentration of firocoxib (Equioxx) is 0.240 micrograms per milliliter. When firocoxib (Equioxx) is administered, the dose should be accurately calculated according to the actual weight of the animal. For a 1,000-pound animal, the maximum daily dose is 45.5 milligrams, which equals 0.1 milligrams per kilogram of body weight once daily. No part of a dose should be administered during the 12 hours prior to competition. Firocoxib (Equioxx) should not be administered for more than 14 successive days.
12. Omeprazole (GastroGard or UlcerGard) - No part of a dose should be administered within 24 hours prior to competition.

E. DRUG VIOLATIONS

It shall be a violation of this rule for any person to:

1. Administer, aid in the administration, cause to be administered or conspire in the administration of any forbidden substance in any manner to a horse before or during any ApHC approved or sponsored event in which that horse is shown.
2. Administer, aid in the administration, cause to be administered or conspire in the administration of any substance to a horse which may interfere with

ApHC's drug testing procedures or the detection of any forbidden substance or quantitation of any substance permitted with limits by this rule.

3. Fail or refuse to cooperate with a licensed veterinarian or his/her agents upon request of any ApHC representative and promptly comply with their requests, including, but not limited to:
 - a. Taking said veterinarian or his or her agents immediately to the location selected by said veterinarian or agents for testing the horse and presenting it for testing.
 - b. Assisting said veterinarian or his or her agents in procuring the sample promptly, including but not limited to removing equipment from the horse, leaving it quietly in the stall, and avoiding any distractions to it. Schooling, lengthy cooling out, bandaging, and other delays of this type are presumed to be non cooperation.
 - c. Maintaining a polite attitude and actions toward said veterinarian and his or her agents.
 - d. The owner, trainer, or other responsible party witnessing the blood or urine sample collection and signing the forms required by the veterinarian, the failure to do so waiving any subsequent objections to the testing process or results.

F. RESPONSIBLE PARTY

Each responsible party shall have absolute responsibility for the condition of the horse and shall be subject to disciplinary action under those rules upon proof of the presence in the horse of a forbidden substance.

G. DISCIPLINARY PROCEDURE

Any person allegedly or presumptively in violation of these drug rules is subject to disciplinary action under these rules.

H. BURDEN OF PROOF

1. The presence in a horse of a forbidden substance proven by laboratory analysis, whether obtained from blood, urine, saliva or other sample, constitutes prima facie evidence that a forbidden substance has been administered to the horse and creates a presumption of a violation of this rule.
2. It is presumed the sample of urine, saliva, blood, or other substance tested by an approved laboratory to which it is sent is the one taken from the horse in question, its integrity is preserved, and that all procedures of same collection and preservation, transfer to the laboratory, and analysis of the sample are correct and accurate, and the report received from the laboratory pertains to the sample taken from the horse in question and correctly reflects the condition of the horse during the show in which he was entered, with the burden being placed on the person(s) charged in the complaint to prove otherwise at any hearing conducted by the ApHC in regard to that matter.
3. These burden of proof provisions shall be applicable in and govern any drug case brought under these rules.

I. ESCROW OF AWARDS

The owner of a horse registered with the ApHC consents and agrees as a condition to receiving points, awards, compensation of any and all types at ApHC-approved or -sponsored events to allow the escrowing of any points, awards, compensation, recognition or monies won or earned by said horse from and after the date of the reporting of a positive drug test involving said horse at an ApHC-approved or -sponsored event and agrees to immediately send to the ApHC all said awards in the responsible party's possession to be held in escrow until the exhaustion of all ApHC hearing procedures and/or subsequent litigation involving the alleged rule violation. All responsible parties for said horse that is found to have forbidden substance in its system, may be required to forfeit all prizes, monies, trophies, ribbons and/or any other awards and points won in said event by said horse.

J. SANCTION AND PENALTY

If found guilty of violation of any ApHC rule pertaining to administration of a forbidden substance, in addition to other penalties that may be imposed under these rules, the accused shall be assessed the following minimum penalties:

1. For administration of conditionally permitted medications in excess of allowable concentrations, payment of all hearing expenses and:
 - a. First offense—\$350 fine and disqualification from the event.
 - b. Second offense—\$700 fine and disqualification from the event.
 - c. Third and subsequent offenses—Penalties to be determined on an individual basis. Minimum recommended penalty for third offense is a six-month suspension, fine to be determined by ApHC, and disqualification from the event. Penalties for subsequent offenses to increase in severity with the possibility of permanent lifetime suspension. The suspension from participation and membership shall remain in effect until the fine is paid in full.
2. For the administration of a forbidden substance other than conditionally permitted medication violations, the penalty is determined by the number of offenses and the classification of the drug according to the applicable ARCI Uniform Classification Guidelines for Foreign Substances and shall include disqualification from the event, payment of all hearing expenses, and:
 - a. First offense with a
 - i. Class 1 Drug, 1–5 year suspension and up to a \$5,000 fine.
 - ii. Class 2 Drug, 6 months–1 year suspension and \$1,500–\$2,000 fine.
 - iii. Class 3 Drug, 2–6 month suspension and up to a \$1,500 fine.
 - iv. Class 4 Drug, 15–60 day suspension and up to a \$1,000 fine.
 - v. Class 5 Drug, 0–15 day suspension with possible fine.
 - b. Second offense with a
 - i. Class 1 Drug, 2–10 year suspension and up to a \$10,000 fine.
 - ii. Class 2 Drug, 1–2 year suspension and \$3,000–\$5,000 fine.
 - iii. Class 3 Drug, 4 month–1-year suspension an up to a \$3,000 fine.
 - iv. Class 4 Drug, 1–4 month suspension and up to \$2,000 fine.
 - v. Class 5 Drug, 1–2 month suspension and up to \$500 fine.
 - c. Third (or more) offense with a
 - i. Class 1–3 Drug, indefinite suspension, suggestion of 11 years or more and up to a \$15,000 fine.
 - ii. Class 4 Drug, 2-year suspension, and up to \$5,000 fine.
 - iii. Class 5 Drug, 1-year suspension, and up to \$2,500 fine.
3. Any horse found to have a forbidden substance in its system shall be suspended from participation in all ApHC-approved and -sponsored events for the same period as the suspensions imposed hereunder against such horse's responsible party and/or parties. The suspension from participation and membership shall thereafter remain in effect until the fine is paid in full.
4. For any such offense, the name(s) of the guilty person(s), rule violation (s), horse(s) involved, identification of the forbidden substance(s) involved and fine(s) imposed shall be published in *Appaloosa Journal* and on the ApHC web site for up to the first 12 months of such suspension and once annually thereafter during the period of suspension. Multiple violations of any forbidden substance rule involving the same horse on the same day will be considered as a single offense. Multiple violations of any forbidden substance rule involving any person subject to these rules and more than one (1) horse on the same day will be considered as a separate offense as to each such horse.
5. In the event of disqualification of horse or horses for just cause in a class at the Youth World Championship Appaloosa Show/National Appaloosa Show or World Championship Appaloosa Show, including but not limited to disqualification for use of forbidden substances, the placings shall be advanced to fill the vacated award positions. Simple advancement will be the procedure and no rescoring of the class in the event of multiple judges will be considered.

K. TEMPORARY SUSPENSION

1. At such time as the ApHC receives written notification of a positive drug test of a horse involving an alleged violation of any ApHC rule pertaining to administration of a forbidden substance, each responsible party for any such horse shall

immediately be placed on temporary suspension and the mandatory minimum restrictions set forth in Rule.60.B. shall apply to each responsible party pending hearing or settlement of the alleged violation.

2. Any responsible party may post a \$1,000 bond to the ApHC in collectible funds at which time the temporary suspension restrictions imposed shall be lifted and the responsible party shall be restored his/her ApHC member privileges pending settlement or hearing.
3. If it is determined by settlement or a hearing that the alleged violation did not occur, the \$1,000 bond will be returned. If it is determined that such violation occurred, the bond amount will be forfeited to the ApHC. This bond forfeiture is in addition to any other penalties, including, but not limited to, additional monetary fines, that may be taken against any responsible party.

Rules 41-44 are not assigned.

45. DEVICES AND APPLIANCES

A. PROHIBITIONS

No horse can be shown in any ApHC-approved or -sponsored event if the horse has had any mechanical device or artificial appliance placed upon or inserted or implanted in its body or has undergone any surgical or other procedure (except castration or spaying procedures) which could alter a horse's natural conformation or appearance or which could affect the performance of a horse. This rule applies to mechanical devices, artificial appliances, surgical procedures or other procedures which could affect a horse's natural conformation or appearance or which could affect the performance, soundness or disposition of a horse even though placed, inserted, implanted, or performed by a licensed veterinarian for the sole purpose of protecting the health of a horse unless and until a report of the licensed veterinarian performing such procedure has been received by the ApHC. Such report shall include the name and ApHC registration number of the horse, the date such procedure was performed, a description of the procedure performed by the veterinarian and a statement of the veterinarian detailing the reasons why such procedure was performed by him or her, in what way the horse's performance and/or its natural conformation or appearance was affected by the procedure and an affirmative statement by the veterinarian that the procedure was performed by him or her for the sole purpose of protecting the health of the horse. If at any time the purpose for the performance of any such procedure is shown to have been for a reason or reasons other than the sole purpose of protecting the health of the horse each responsible party shall be subject to disciplinary action under these rules.

1. Tails may be lengthened by hair-to-hair attachment only, with no attachments of any kind to the tailbone. Artificial tails consisting of fabric and hair are permissible. Weighted tails are permissible, provided they meet the following criteria:

- a. Tail attachment is made hair to hair.
- b. Humane conditions are maintained as outlined in Rule 30.A.1.
- c. The designated judge or equipment judge shall determine if the tail meets the criteria or if the weight of the attachment is excessive. Their decision will be final.

2. The use of earplugs and/or cotton in a horse's ears is not prohibited by this rule.

B. APPLIANCE VIOLATIONS

It shall be a violation of this rule for any person to: insert, implant, place or attempt to insert, implant or place or conspire with another to insert, implant or place or employ anyone who inserts, implants, or places or attempts to insert, implant or place either before or during any ApHC approved or sponsored event any mechanical device, artificial appliance, or perform any surgical procedures or other procedure on a horse which could alter a horse's natural conformation or appearance or which could

affect the performance, soundness or disposition of a horse to be shown in any class at such ApHC approved or sponsored event.

C. RESPONSIBLE PARTY

Each responsible party shall have absolute responsibility for the condition of the horse and shall be subject to disciplinary action under these rules upon proof of a device, appliance or procedure prohibited by this rule being found or detected.

D. DISCIPLINARY PROCEDURE

Any person allegedly or presumptively in violation of these drug rules is subject to disciplinary action under these rules.

Rules 46-49 are not assigned.

50. RESPONSIBLE PARTY

A. DEFINITION

Any person with authority over or responsibility for the care, training, custody or performance of a horse, including, but not limited to, an owner, lessee, trainer, exhibitor, rider or handler, and any person signing an entry form for a horse is defined for purposes of these rules as a responsible party for that horse. By way of examples: a trainer is presumed to represent an owner of a horse in the management, training, entering, scratching or other acts or decision making related to the horse under the care and custody of the trainer; both the exhibitor designated on the entry blank and one physically participating with the horse in the event are conclusively presumed to be authorized by the owner to execute all documents necessary or convenient to allow the horse's participation in an ApHC approved event, including documents pertaining to drug testing; the exhibitor and owner acknowledge an exhibitor also represents the owner in regard to his or her horse entered in an ApHC-approved or sponsored show.

B. ABSOLUTE RESPONSIBILITY

Each responsible party, jointly and severally, is absolutely responsible for a horse's condition and is presumed to know all of the rules and regulations of the ApHC, including sanction and penalty provisions. These rules provide for such absolute responsibility in ApHC rules pertaining to drugs or surgical alteration whether or not the responsible party had actual knowledge of the administration of such drug or surgery thereby making such person eligible for possible disciplinary action upon proof of the presence of such drug by laboratory analysis or existence of surgical alteration. The voluntary action of each responsible party in entering or exhibiting a horse in an approved or sponsored event makes such person eligible for disciplinary action.

C. SUBSTITUTION OF DUTIES

If the exhibitor owner or trainer designated on the entry blank is prevented from performing his or her duties, including responsibility for the condition of the horse in his or her care, by illness or otherwise, or is absent from any event where horses under his or her care are entered or stabled, he or she shall immediately notify the show secretary and, at the same time, appoint a substitute, and such substitute shall place his or her name on the entry blank forthwith.

D. REBUTTABLE PRESUMPTION

A responsible party may rebut the presumption that he or she is responsible for the condition of the horse by clear and convincing proof that he or she, at all relevant times and for good reason or cause, was prevented from performing duties related to the condition of the horse or was not involved in any manner whatsoever with the condition of the horse or in making decisions regarding the condition of the horse.

Rules 51-59 not assigned.

60. GENERAL PENALTIES AND SANCTIONS

A. EXTENT OF SANCTIONS

1. In regard to any violation of ApHC rules and regulations, the Disciplinary Committee shall have jurisdiction:

- a. To invoke sanctions, including revocation, suspension or denial of membership privileges, revocation or suspension of ApHC judge's credentials or any other ApHC accreditation, denial of privilege to advertise in *Appaloosa Journal*, revocation or suspension of participation privileges in any capacity at all or any ApHC-approved or -sponsored shows or events for a definite or indefinite period, suspension of horses owned wholly or in part from participation at all or any ApHC-approved or -sponsored shows for a definite or indefinite period, denial of privilege of access or presence on show grounds of an ApHC-approved or -sponsored show or event, denial of ApHC registration privileges, assessment of fine not to exceed \$5,000 for each violation and assessment of costs incurred by ApHC to process and conduct any hearing or to participate in any legal proceeding, including, but not limited to, reasonable administrative and attorney fees, travel, telephone and hearing expenses. In the event a fine is assessed, an indefinite period of suspension may be imposed pending payment of any such fine and/or a definite period of suspension may be imposed after payment in full of any such fine.
- b. To enhance suspension, penalty and/or fine of repeat offenders of ApHC rules and regulations and include owners or lessees who have placed the care or custody of their horses to such repeat offenders, to a maximum of indefinite suspension of membership privileges and/or fine to a maximum of \$5,000 for each violation.
- c. To suspend any horse found to have a forbidden substance in its system or an artificial appliance or mechanical device or surgical procedure or artificial characteristic(s) or coat pattern in violation of these rules from participation in all or any ApHC approved or sponsored events for a definite or indefinite period of time.
- d. To cancel or amend an ApHC Certificate of Registration and/or require an owner to deliver an ApHC Certificate of Registration to the ApHC.
- e. To escrow and/or cause to be forfeited all or any prizes, money, trophies, ribbons, points and/or awards won by a horse at an ApHC approved or sponsored event.
- f. To publish the name of the person, the violation, and the sanction in *Appaloosa Journal* and/or the ApHC web site and/or by electronic communication to ApHC members.
- g. Any person found guilty and suspended for inhumane treatment or drug violations under ApHC rules shall not be eligible for induction into the Hall of Fame and/or for Trainer of the Year.
- h. To impose any other penalty, fine and/or sanction provided under ApHC rules and regulations.

B. MINIMUM MANDATORY RESTRICTIONS

The following mandatory minimum restrictions, in addition to any other terms and conditions that may be imposed, shall apply during the applicable period to any member who has been suspended or expelled or whose membership privileges have been revoked by the Chief Executive Officer or Disciplinary Committee:

1. That member shall be denied all ApHC membership privileges.
2. That member shall not participate and shall be ineligible to participate, except as a spectator, in any ApHC-approved or -sponsored events. Participate is defined as engagement in an equine activity by any person, whether amateur or professional, whether or not a fee is paid to participate in the equine activity. Equine activity includes, but is not limited to, exhibiting, training, inspecting, evaluating, teaching, coaching, riding, driving, grooming or otherwise preparing for the show, stall work (cleaning, feeding, watering), loading and unloading, reserving or paying for stalls or entries, marketing and sales of horses and/or equine products and equine services or interacting in any other way with a horse or exhibitor other than as a spectator at an ApHC-approved or -sponsored event. Complaint of violations of this rule by a suspended or ineligible person

will subject any such person to disciplinary proceedings and sanctions as provided under ApHC Rule 60.

3. With regard to registration matters:
 - a. That suspended person or his or her spouse shall not register any horse with the ApHC or transfer registered horses into his or her name or that of a spouse.
 - b. Any horse sired by a stallion or out of a mare owned by any suspended person shall be ineligible for ApHC registration if the breeding date of the horse occurred after the effective suspension date.
 - c. The ApHC will not accept the signature of a suspended person or his or her spouse on either (i) registration applications, (ii) breeder's certificates or (iii) stallion breeding reports evidencing breeding on or after the effective suspension date; except that any such signature will be honored on transfer reports and bills of sale for the purpose of allowing the suspended person or his or her spouse to transfer horses registered in the suspended person's or his or her spouse's name.
 - d. The validity of written leases filed with the ApHC prior to the suspended person's effective suspension date covering horses owned by the suspended person or his or her spouse shall not be affected by any such suspension and the signature of the lessee under any such written lease shall be accepted during the term of such lease but not for purposes of any renewal thereof.
4. That member shall be ineligible to hold approved ApHC judge's credentials or any other ApHC accreditation.
5. That member shall be ineligible to hold office in the ApHC or in connection with any ApHC approved or sponsored event.
6. The horse, if any, involved in the violation shall be suspended and the suspension of the horse shall not be affected by the transfer of ownership, if any, during the period of suspension.

C. WAIVER

To prevent hardship to an innocent person, the Chief Executive Officer has discretion, upon convincing proof of such hardship or innocence, to waive any suspension restriction regarding registration matters if all other ApHC registration or transfer requirements under these rules are met.

Rules 61-69 are not assigned.

BOARD OF DIRECTORS PROCEDURES

70. The Board of Directors shall adopt, amend and/or eliminate a rule and/or regulation only in the following manner.

- A. A motion proposing to adopt, amend and/or eliminate a rule and/or regulation shall be approved (approval motion) or disapproved (disapproval motion) by the Board of Directors at a meeting (proposal meeting) conducted at least ninety days before a regular meeting of the Board of Directors.
- B. All approved motions and disapproved motions shall be published and distributed to the members within sixty days after the proposal meeting along with notice of a regular meeting of the Board of Directors (the rule change meeting) to be conducted at least ninety days following the proposal meeting at which approval motions and disapproval motions will be considered by the Board of Directors.
- C. Following such publication, distribution and notice of members, the Board of Directors may adopt, amend, and/or eliminate a rule and/or regulation by adopting an approval motion or disapproval motion at the rule change meeting. At such rule change meeting the Board of Directors may also make related amendments to the approval motion or disapproval motion.
- D. Notwithstanding the above, the Board of Directors may adopt, amend, and/or eliminate a rule and/or regulation at any meeting without following the

procedures set forth in this section, provided a separate motion be approved with specific findings of fact determining that the welfare and/or orderly administration of the ApHC will be better served without following the procedures set forth in this section.

Code of Ethics

Following are general principles each board member should use to evaluate their conduct in meeting responsibilities to the ApHC Board of Directors, general membership, and to fellow board members. The ultimate success of the ApHC and its programs depends, to a large degree, on the sound judgement and unbiased attitude of the few, who comprise its board of directors.

1. Attendance: A member shall attend and fully participate in called meetings of the board of directors to exercise the individual responsibility granted to them by the board.
2. Conflict of Interest: A member shall avoid a business or personal situation having a potential for conflict or appearance of conflict with their responsibilities to the ApHC, or which could tend to compromise their primary duty to further the purposes and policies of the Appaloosa Horse Club.
3. Self-Interest: A member shall refrain from the use of the ApHC, its personnel or property to further their own purposes or business gain, and shall avoid situations or receipts of benefits which hint of favoritism.
4. Confidentiality: A member may not divulge to any third party information regarding confidential ApHC registration, membership information, executive session discussions, personnel matters and similar matters of sensitivity to ApHC operations. Copies of minutes of meetings of the board of directors and its committees may be circulated to other persons unless they contain any such confidential information, in which case such minutes must remain confidential.
5. Opposing Points of View: A member will endeavor to foster harmonious relationships with other members by frank and good-faith discussion in meetings, and at all times be open minded, recognizing that expression of an opposing viewpoint is often healthy to ultimate decision making.
6. Pending Litigation: To coordinate the ApHC's approach to the case, a member shall avoid individual discussion with a litigant or third parties concerning any litigation pending against the ApHC, but shall refer all inquiry to the board of directors or to the ApHC attorney.
7. Judging an ApHC-Sponsored Show: While serving on the ApHC Board of Directors, a director shall not judge the National and/or World Show.
8. No one or no group, regardless of organizational designation, shall represent themselves as an ApHC spokesperson without prior approval of the ApHC Executive Committee. This shall include but not be limited to printed and/or electronically transmitted material.

Executive Session

An executive session is any meeting or part of a meeting of the Appaloosa Horse Club board of directors that is closed to any persons for deliberation on certain matters. The ApHC board of directors may hold an executive session during any meeting in accordance with the following guidelines and procedures:

- A. Executive session may be held for deliberation concerning the following matters:
 1. Employment of ApHC officers, including but not limited to evaluations, negotiations and complaints.
 2. At the request of the ApHC Chief Executive Officer to discuss any ApHC personnel matter.
 3. Complaints involving any member of the board of directors.
 4. Disciplinary hearing involving a member or non-member.
 5. Negotiations involving ApHC commercial activities.
 6. Pending, threatened or possible litigation.

B. Executive session may be called as follows:

1. The ApHC President, at his/her discretion, has the right to call an executive session and shall cite the appropriate purpose.
2. Any ApHC Director may move the ApHC President to call an executive session and shall cite the appropriate purpose. If the ApHC President declines to do so, any other director may second the motion for executive session, and upon the affirmative vote of at least two-thirds (2/3) of the directors present at the meeting, the executive session will be called.
3. Executive session is held for the purpose of free exchange of information on sensitive topics. Any matter discussed in executive session shall remain confidential and shall not be discussed with any person not present in the session. Any board action taken as a result of discussions held within executive session must take place in open meeting of the ApHC board of directors.

Rules 71-99 are not assigned.

DEFINITIONS

The following are definitions of terms used throughout the *Official Handbook*, and should be referred to as indicated for a full understanding of the rules and regulations.

100. ACTIVE MEMBER - A member, active member or an active member in good standing as those terms are used in these rules is an individual whose membership application has been approved in accordance with ApHC bylaws, who has paid the requisite membership fee and who is not under current suspension from membership by the ApHC.

101. AGE - The age of horses is computed from the first of January; e.g. a horse shall be considered to be one year old on the first of January following the actual date of foaling. The age of an individual for horse show purposes shall be based on the individual's age on January 1, e.g. the individual's age on January 1 shall be maintained throughout the entire year.

102. APPLICATION FOR REGISTRATION - A written application for registration giving all required information on the horse. There are also application forms for transfer of ownership, advancement to permanent, etc.

103. ARTIFICIAL COLORING - Any color or changes of color that do not result from natural processes.

104. ARTIFICIAL INSEMINATION (AI) - Insemination by other than natural means. The mare is not covered by the stallion, and the semen is deposited in the uterus by mechanical means.

105. BASE COLOR - The dominant color of a horse. It is determined from the body, neck and head area.

BAY - Body color ranging from tan, through red, to reddish brown; mane and tail black; usually black on lower legs.

BAY ROAN - Body color bay, with a uniform mixture of white hairs, may have varnish marks.

BLACK - Body color true black without light areas; mane and tail black.

BLUE ROAN - More or less uniform mixture of white and black hairs, usually with a few red hairs and may have varnish marks.

BUCKSKIN - Body color yellowish or gold; mane and tail black; black on lower legs; buckskins do not have dorsal stripes.

CHESTNUT or **SORREL** - Body color varies from light washy yellow to dark liver in color. Never has black mane, tail or legs, but may have black hairs in mane and tail. May also have a flaxen mane and tail but mane and tail are usually the same color as body.

CREMELLO or **PERLINO** - Cremellos have pink skin, blue eyes and ivory hair.

Perlinos also have pink skin, blue eyes and ivory hair except the mane and tail are darker than the body. Cremellos and Perlinos do not have dorsal stripes.

DARK BAY or **BROWN** - Body color brown or black with light areas at muzzle, eyes, flanks and inside upper legs; mane and tail black.

DUN - Body color yellowish or gold; mane and tail may be brown, red, yellow or mixed; often has dorsal stripe, zebra stripes on legs and transverse stripe on withers.

GRAY - Mixture of white and darker hairs; usually born solid-colored or almost solid-colored and gets light with age.

GRULLA - Body color smoky or mouse-colored, (not a mixture of black and white hairs, but with each hair mouse-colored); mane and tail black, usually black on lower legs.

PALOMINO - Body color a golden yellow, mane and tail white.

RED ROAN - More or less uniform mixture of white and red hairs, and may have varnish marks.

WHITE - A true white horse is born white and remains white throughout its life. A white horse has snow white hair, pink skin and normally brown eyes.

106. BREEDER - Owner of the dam at the time of service unless the dam was under a lease at the time of breeding and written notice of such lease, signed by the lessee and lessor, is on file with the ApHC at the time of registration. In that case, the lessee is the breeder of the foal.

107. BREEDER'S CERTIFICATE - Written verification signed by the stallion owner listing the stallion used for breeding, the mare bred, and the dates the breeding or breedings took place, or the period the mare was exposed to the stallion, in the case of pasture breeding.

108. BREEDING STOCK REGISTRATION - Category for Appaloosas registered before January 1, 1983, that did not show typical Appaloosa coat patterns or characteristics so as to be easily recognizable as an Appaloosa; however, the sire and/or dam must have been registered in the ApHC.

109. CPO (CERTIFIED PEDIGREE OPTION) - The Certified Pedigree Option (CPO) program, in effect from 1983 through 2006, provided that Appaloosa horses registered with a non-characteristic (N) classification that met CPO program requirements received a CPO (CN) classification and had a CN prefix inserted before the registration number on that horse's Certificate of Registration. As more particularly set forth in ApHC rules, a horse with a CPO (CN) designation is eligible to show in ApHC-approved events and, if qualified, in ApHC-sponsored events and may be advanced to Regular (#) registration if it subsequently develops those Appaloosa characteristics as required under Appaloosa Horse Club rules.

110. CERTIFICATE OF REGISTRATION - A document attesting to an animal's age, pedigree, breeder, owner and description.

111. CHARACTERISTICS - The Appaloosa horse can have four identifiable characteristics:

1. Coat Pattern
2. Mottled Skin
3. White Sclera
4. Striped Hooves

112. CLONING - Cloning, as applied to horses, is defined as any method by which the genetic material of an unfertilized egg or an embryo is removed or replaced by genetic material taken from another organism, added to/with genetic material from another organism or otherwise modified by any means in order to produce a live foal.

113. COMPUTER FLAGGING - The ApHC will charge a fee for requests to place notes, comments, etc. in the ApHC computer regarding a particular ApHC horse file. Contact the ApHC for details. (See Fee Schedule.)

114. COWLICK - A lock or tuft of hair growing in a different direction from the rest of the hair.

115. CRYOGENICS (FREEZE MARKING) - A permanent, painless, unalterable means of identification which destroys the pigment producing cells that give the hair its color so as to leave a mark of white hair.

116. CRYPTORCHID - A horse in which both of the testicles have failed to normally descend into the scrotum by three years of age.

117. EMBRYO - A fertilized egg, removed from a bred donor mare and placed into a recipient mare.

118. EXHIBITOR - Owner, lessee, contestant, handler, trainer and/or rider shall be known as exhibitors.

119. FACE MARKINGS - White markings on the face of a horse which are used in describing and positively identifying a horse.

STAR - Any marking on the forehead.

STRIPE - A vertical marking found below the eye level and above the imaginary horizontal line connecting the top of the nostrils.

SNIP - Any mark found below the top of the nostrils.

SNIP LOWER LIP - Any marking found on lower lip.

STAR AND SNIP - A marking on the forehead with disconnected marking between or below the nostrils.

STAR AND STRIPE - A marking on the forehead with a stripe to the nasal peak. The stripe does not have to be an extension of the star.

STRIPE AND SNIP - A narrow marking extending vertically, beginning below the eyes and ending just below or between the nostrils.

STAR, STRIPE AND SNIP - A marking on the forehead with an extension to between or below the nostrils.

BLAZE - A large or wide connected white star, stripe and snip of uniform width.

BALD FACE - A very large blaze which can extend outside of the eyes in the forehead and center of face, covering the width of the bridge of the nose and over the entire muzzle.

120. FALL - A horse is considered to have fallen when the shoulder and flank or quarters on the same side have touched the ground or an obstacle and the ground. A exhibitor is considered to have fallen when he/she is separated from his/her horse, that has not fallen, in such a way that he/she must remount or vault into the saddle.

121. FAMILY - Definitions for "family" as related to ownership of horses being show in youth or non-pro classes at ApHC-approved or -sponsored events can be found in the appropriate youth and non-pro sections of this Handbook.

122. FOUNDATION - Registration numbers were issued to the Foundation stock of the breed that were originally accepted for registration as they met the requirements. There are only 4,932 Foundation numbers.

123. INSPECTION - Visual examination of a horse by an ApHC-approved inspector to gather data to be submitted in report and picture form to the Registrar of the ApHC to determine whether the horse meets the registration requirements of the ApHC, and/or to identify the horse from the appropriate registration application or Certificate of Registration.

124. INSPECTOR - A person designated by the Chief Executive Officer or Registrar to visually inspect a horse to gather data both in pictorial and report form to assist the Registrar in determining whether or not the horse meets the registration requirements of the ApHC. An inspector may also be authorized to tattoo any horse which has passed inspection.

125. INTERNATIONAL REGISTRATION INCENTIVE PROGRAM - The International Registration Incentive Program ("IRIP"), in effect beginning in 2008, provides that a horse registered with an ApHC-approved national or multinational Appaloosa registry that meets all program requirements as set forth in ApHC rules is eligible for an IRIP Certificate of Registration. Horses registered in IRIP are issued identification numbers that run consecutively with ApHC registration numbers and are classified as an "I#" or "IN" depending upon whether, regular required characteristics are present or not, respectively. Horses registered in IRIP are ineligible to participate in ApHC-approved or -sponsored events. Horses registered in IRIP are approved for crossbreeding in accordance with ApHC registration requirements.

126. LEG MARKINGS - White markings on the legs of a horse which are used in describing and identifying a horse.

HEEL - A white marking found across the entire heel or simply on one side.

CORONET - A white marking from the foot to the first inch above the hoof, extending all the way around the foot to be inclusive of the heel.

PASTERN - A white marking that extends from the top of the hoof up to the bottom of the ankle or fetlock joint.

ANKLE - A white marking that extends from the top of the hoof to the top of the ankle joint.

HALF STOCKING - A white marking that extends to the midway point of the cannon bone.

STOCKING - Any white marking extending from the hoof covering the leg up to the bottom of the knee or hock or above the knee or hock.

127. MONORCHID - A horse in which one of the testicles has failed to normally descend into the scrotum by three years of age.

128. MOTTLED SKIN (PARTI-COLORED SKIN) - The Appaloosa horse is the only horse to have this characteristic, and therefore mottled skin is a very basic and decisive indication of an Appaloosa. Mottled skin is different from pink (flesh colored or non-pigmented) skin in that it will normally contain small, round, dark spots (pigmented skin) within its area. It is therefore a speckled pattern of pigmented skin. If a horse has mottled skin, it is apt to be found in the anus region. It normally is seen spreading from the center of the anus to include the surrounding area. Mottled skin is often found on the udder or sheath (it is not found on the penis).

Many breeds of horse will have a few small specks of flesh colored (non-pigmented) skin in this region which again should not be confused with mottled skin. Many Appaloosas will have varying amounts of mottled skin on their muzzle, the mottled skin can extend over both nostrils and around the upper and lower lip regions. All horses have a line on the lips caused by the contrast of pigmented skin and non-pigmented skin. Again, all horses have this, and therefore, a person should not separate the lips for signs of mottled skin.

129. (N) NON-CHARACTERISTIC REGISTRATION - Category for Appaloosas registered after January 1, 1983 that do not show any identifiable Appaloosa characteristics so as to be recognizable as Appaloosa, and which are registered as an N horse under these rules. However, the sire and/or dam must be registered in the ApHC.

130. OOCYTE - An unfertilized egg, removed from donor mare and placed into a recipient mare, and recipient mare is then bred.

131. NON-MEMBER - A person who has not applied for membership with the ApHC, or a person whose membership dues are not currently paid to the ApHC.

132. OWNER - For purposes of interpretation of ApHC rules the last person(s) named on the Certificate of Registration issued by the ApHC shall be considered the owner. Executed transfer reports or bills of sale transferring the ownership of a horse

from the recorded owner to a new purchaser will not be evidence of ownership until all requirements are met and the transfer is processed. (See also TRANSFER OF OWNERSHIP.)

133. PARROT MOUTH - Either overshot or undershot and is defined by the American Association of Equine Practitioners as "no occlusal contact between the upper and lower central incisors."

134. PEDIGREE - A record of the ancestry of an animal.

135. PERFORMANCE PERMIT - The Performance Permit program, in effect beginning in 2007, provides that an Appaloosa horse registered with a non-characteristic (N) classification that meets the Performance Permit program requirements more particularly set forth in ApHC rules will be issued a Performance Permit and be eligible to participate in ApHC-approved events, and if qualified, ApHC-sponsored events and the registration certificate for that horse will be amended to show that the horse has been issued a Performance Permit.

136. PERMANENT - Prior to 1983, permanent registration was a registration category for Appaloosas which had both sire and dam registered in Permanent or Foundation registration. Permanent registration was automatically issued to geldings and spayed mares as they did not reproduce. Permanent registration can be earned by mares that produce three Regularly-registered foals and by stallions that sire twelve Regularly-registered foals.

137. POSITIVE IDENTIFICATION SYSTEM - A system of exact identification of a horse using multi-methods such as photographs, tattooing, brands, identifying scars, face, leg and coat markings. Not to be confused with the ApHC Identification System.

138. PRODUCE - Offspring.

139. PRODUCTION REQUIREMENT - The production requirement for the Tentative registered mare to pass to Permanent is the production of three Regularly-registered Appaloosa foals. The production requirements of a Tentative stallion to pass to Permanent is siring twelve Regularly-registered Appaloosa foals.

140. PULLED HAIR

A. Hair can be pulled or cut to be used in polarization stress analysis in order to determine whether or not cryogenic alteration has occurred.

B. Pulled hair follicles will be one method used to determine DNA test results.

141. REATA - Spanish for lariat.

142. REGULAR REGISTRATION - Entitles an Appaloosa to compete in horse shows, races or any type of competition or exhibition. To be issued Regular papers, it is necessary that the horse display a characteristic Appaloosa coat pattern, or mottled skin and one other Appaloosa characteristic.

143. SPAYED MARE - Filly or mare that has been spayed (i.e. rendered incapable of conception by whatever procedure, including removal of the ovaries).

144. STALLION BREEDING REPORT - A form listing the stallion's name, registration number, and owner. It lists all mares exposed to the stallion during the calendar year, the dates they were bred or exposed, their breed type, sire and dam and registration numbers, and the name of the owner at the time of service. It is signed by either the stallion owner, lessee or an authorized agent.

145. STRIPED HOOVES - Bold and clearly defined vertically light and dark striped hooves on legs that do not have white leg markings.

146. TATTOOER - A person designated by the ApHC Board of Directors and/or the Chief Executive Officer to tattoo registered Appaloosa horses.

147. TATTOOING - The placing of a numerical mark on the inside of a horse's upper lip by means of a tattoo dye and the application of tattoo ink to assist in the identification of the horse. In Appaloosas, the tattoo number and registration number are the same. Most states require tattooing in order to race in state racing commission approved races.

148. TRAINER - Any person who has responsibility for the training and performance of a horse, youth or non-pro exhibitor.

149. TRANSPORTED SEMEN - Semen transported from the location of collection.

150. WHITE SCLERA - A horse is said to have white sclera when there is white area completely encircling the dark or pigmented iris of the eye. It should be easily seen and should completely encircle the eye. White sclera can be used as a characteristic of an Appaloosa, provided it is not in combination with a bald face. If a horse has a bald face, the Registrar may discount the white sclera.

Rules 151-199 are not assigned.

200. RULES AND REGULATIONS OF REGISTRATION

- A. Applicants are responsible for knowledge of all registration rules and regulations.
- B. Registration of a horse with the ApHC is based and predicated upon the agreement, acceptance, and consent of the applicant that the final decision on all registrations and classification matters and the final interpretation of all rules contained from time to time in this handbook shall be made by the Board of Directors of the ApHC or an authorized committee thereof and that the decisions and interpretations of the Board or authorized committee shall be binding on all parties.
- C. Registration eligibility for all horses is predicated on information supplied and forwarded to the ApHC Registration Department on properly completed and signed official application forms, from photographs, from examination and/or inspection, from results of genetic testing and/or from any other source. All information obtained by the ApHC becomes the property of the ApHC, and the ApHC is authorized to utilize all such information for any purpose. The burden of proving eligibility for registration of any horse with the ApHC rests with the applicant.
- D. As a prerequisite to registration or change in registration classification, the Registrar may require an inspection and/or examination of the subject horse. Prior to the inspection, the owner shall pay actual and necessary expenses for the inspection. Upon request, the owner shall transport the horse to a convenient location to permit the inspection and/or examination. The registration application or requested change in classification shall be rejected if the horse is not eligible for registration under these rules and if the owner of the subject horse refuses to permit the inspection and/or examination. The registration is subject to suspension, revocation or correction.
- E. The ApHC will not be liable for any error or misrepresentation on the application for registration or subsequently issued Certificate of Registration, and, in case of such error or misrepresentation, the ApHC reserves the right to suspend, revoke or correct the issued Certificate of Registration and the entry of the named horse in accordance with the Protest, Inspection and Appeal Procedures set forth in this handbook.
- F. The face of all ApHC Certificates of Registration read: The certificate is written evidence of the breeding of the below named animal. This acceptance is based

upon an application duly certified by the breeder or owner. This certificate is subject to correction and cancellation under the By-laws of the Appaloosa Horse Club. The ApHC will not be liable under this certificate for any mistake therein, based upon error or misrepresentation in the application thereof; and in case of such error or misrepresentation the Appaloosa Horse Club reserves the right to cancel or correct this Certificate of Registration.

- G. The owner of a horse registered with the ApHC consents and agrees, as a condition to receiving said Certificate of Registration, to allow the escrowing of any points, awards, recognition, or monies won or earned by said horse from and after the date of filing of any protest against said horse pursuant to the protest and identification provisions of the *Official Handbook of the ApHC*.
- H. ApHC staff is authorized, but not required, to accept a facsimile (fax) transmission of an original document, when, in the opinion of ApHC staff, the sender is 1) the authorized party executing the document or 2) a party having substantial interest in the subject horse, has obtained the original document from the authorized person and so verifies the genuineness of the document in the sender's possession to the satisfaction of ApHC staff. As a precaution, the fax should be followed by the mailing of the original document, but this requirement is not a condition of accepting the fax.
- I. The ApHC, its agents and/or inspectors, shall have a right of access to farms, ranches, breeding facilities and any other places or facilities owned, leased and/or controlled by members and/or non-members, where any horse: (a) registered, identified and/or listed on any report filed with the ApHC; (b) for which a registration application has been filed with the ApHC; or (c) which is alleged to be an ancestor of a registered horse, or identified horse, or horse listed on any report filed with the ApHC or horse to be registered; is, or to the best of the ApHC's knowledge, may be located at any such place or facility, for the purpose of inspecting any such horses, assisting breeders or owners with ApHC administrative requirements, taking photographs, undertaking any testing and/or identification procedures, completing inspections and/or reports and any other purpose reasonably related to ApHC's registration processes, as determined by the ApHC, its agents and/or inspectors. The member and/or nonmember will be presented a letter from the ApHC at the time such access is demanded and no prior notice shall be required. Any such inspection may occur at any time during the year and shall occur during daylight hours for such reasonable time as may be necessary, in ApHC's sole discretion, to accomplish such purposes.

201. REGISTRATION CLASSIFICATIONS

- A. Prior to 1983, horses were registered as Regular (#), Tentative (T), Breeding Stock in a Tentative (BT), Permanent (B#) or Non-characteristic (BN) category, Identification System (ID), or Pedigree Certificate (PC).
- B. Tentative (T) registration was the registration category assigned to Appaloosas that met registration requirements, but did not have both sire and dam registered in the Permanent or Foundation stock. If the sire and/or dam were registered Tentative, registered with an approved breed association, Identified (ID) or Pedigree Certificate (PC) registered, Tentative Registration was issued. A "T" precedes the registration number.
 1. When a Tentative registered horse passes to Permanent, the T prefix is dropped and the number remains the same. Prior to January 1, 1983, in order for a horse to have been directly registered in the Permanent registry, it must be sired by and have been out of Permanent numbered and/or Foundation registered parents.
 2. Registration numbers with no prefix, or with a pound sign (#) indicate Permanent registration. Permanent registration was earned by mares that produced three Regularly registered foals and by stallions that sired twelve Regularly registered foals.
- C. If a horse did not display an Appaloosa coat pattern, it was registered in the

Breeding Stock category with either Tentative (BT), Permanent (B#) or Non-Characteristic (BN) Certificate of Registration. Breeding stock was a registration category for an Appaloosa-bred horse that did not show some Appaloosa coat markings so as to be easily recognizable as an Appaloosa. However, the sire and/or dam had to be registered with the ApHC. The Breeding Stock category is being phased out. Horses with Breeding Stock papers may submit them to the Registrar for advancement. Breeding Stock horses that do not display characteristics will have an N preceding their registration number. It will state on the Certificate of Registration that such horses have no Appaloosa characteristics. No horses will be registered as Breeding Stock or Breeding Stock-N after January 1, 1983.

- D. The Identification System, (ID) recorded and identified horses which were used in, or produced by, Appaloosa breeding programs that were not eligible to register with the ApHC or another recognized breed association. This system was replaced by the Pedigree Certificate (PC) System at the November 1974 Board of Director's meeting.
- E. The Pedigree Certificate (PC) was for all horses that did not display Appaloosa characteristics. Non-Appaloosas which did not have Appaloosa breeding, such as half-Thoroughbred and half-Quarter Horse, were issued white certificates. Non-characteristic Appaloosas having one or both registered Appaloosa parent(s) were issued tan colored certificates.
- F. Numbers carrying an F prefix indicate Foundation registration. Foundation registration numbers were issued to the horses first registered with the ApHC. There are 4,932 Foundation horses.
- G. Horses registered on or after January 1, 1983 that have a pound sign (#) preceding their registration number indicates Regular registration. Regular registration required characteristics are (i) Appaloosa coat pattern, or (ii) mottled skin and one other Appaloosa characteristic. The Appaloosa can have four identifiable characteristics:
 - 1. Coat Pattern;
 - 2. Mottled Skin;
 - 3. White Sclera; and
 - 4. Striped Hooves.

When it appears from the submitted photographs that the subject horse is not eligible for Regular registration as defined herein, then the registration application shall be rejected unless the horse is eligible for N registration.

- H. Non-characteristic (N) is a registration category for an Appaloosa-bred horse that does not display identifiable Appaloosa characteristics as defined herein. However, the sire and/or dam must be registered with the ApHC. Non-characteristic horses registered on or after January 1, 1983 that do not display the necessary characteristics to receive Regular registration will have an N prefix before the registration number. Horses registered as N or CN may subsequently develop Appaloosa characteristics so as to be recognizable as an Appaloosa. The owner may then request that the registration classification of the horse be advanced to Regular registration. See ADVANCEMENT TO REGULAR REGISTRATION.
- I. The Certified Pedigree Option (CPO) program, in effect from 1983 through 2006, provided that Appaloosa horses registered with a non-characteristic (N) classification that met CPO program requirements received a CPO (CN) classification and had a CN prefix inserted before the registration number on that horse's Certificate of Registration. As more particularly set forth in ApHC rules, a horse with a CPO (CN) designation is eligible to show in ApHC-approved events and, if qualified, in ApHC-sponsored events and may be advanced to Regular (#) registration if it subsequently develops those Appaloosa characteristics required under ApHC rules. If a horse is advanced from a CPO (CN) designation to Regular (#) registration, the CN prefix is replaced with a pound sign (#) to indicate Regular registration and the number remains the same.
- J. The International Registration Incentive Program ("IRIP"), in effect beginning

in 2008, provides that a horse registered with an ApHC-approved national or multinational Appaloosa registry that meets all program requirements as set forth in ApHC rules is eligible for an IRIP Certificate of Registration. Horses registered in IRIP are issued identification numbers that run consecutively with ApHC registration numbers and are preceded with an "I#" or "IN" depending upon whether regular registration characteristics are present or not, respectively. Horses registered in IRIP are ineligible to participate in ApHC approved or sponsored events. Horses registered in IRIP are approved for crossbreeding in accordance with ApHC registration requirements.

202. REGULAR (#) REGISTRATION REQUIREMENTS

- A. Regular registration required characteristics are (i) Appaloosa coat pattern, or (ii) mottled skin and one other Appaloosa characteristic. The Appaloosa can have four identifiable characteristics:
 - 1. Coat Pattern;
 - 2. Mottled Skin;
 - 3. White Sclera; and
 - 4. Striped Hooves.

203. NON-CHARACTERISTIC (N) REGISTRATION

- A. When it appears from the submitted photographs that the subject horse is not eligible for Regular registration as defined herein, then the registration application shall be rejected unless the horse is eligible for N registration.
- B. N is a registration category for an Appaloosa-bred horse that does not display identifiable Appaloosa characteristics as defined herein. However, the sire and/or dam must be registered with the ApHC.
- C. Breeding stock was a registration category for an Appaloosa-bred horse that did not show some Appaloosa coat markings so as to be easily recognizable as an Appaloosa. However, the sire and/or dam had to be registered with the ApHC. The Breeding Stock category is being phased out. Horses with Breeding Stock papers may submit them to the Registrar for advancement.
- D. Breeding Stock horses that do not display characteristics will have an N preceding their registration number. It will state on the Certificate of Registration that such horses have no Appaloosa characteristics. No horses will be registered as Breeding Stock or Breeding Stock-N after January 1, 1983.
- E. Horses registered as N or CN may subsequently develop Appaloosa characteristics so as to be recognizable as an Appaloosa. The owner may then request that the registration classification of the horse be advanced to Regular registration. See ADVANCEMENT TO REGULAR REGISTRATION.

204. BLOODLINE REQUIREMENTS

To be eligible for registration with the ApHC, horses must have:

- A. One parent with an ApHC registration classification of Regular (#); and
 - 1. The other parent with one of the following ApHC registration classifications: Regular (#), N, CN, BT, B#, ID, PC, I#, IN; or
 - 2. The other parent registered with one of the following ApHC-approved breed associations:
 - a. American Quarter Horse Association (AQHA)
 - i. All AQHA-registered stallions and mares that have the following or similar notation on their Certificate of Registration: "This horse has white markings designated under AQHA rules as an undesirable trait and uncharacteristic of the breed," are ineligible as an ApHC-parent under this rule, unless those white markings are determined by the ApHC Registrar to be an Appaloosa coat pattern.
 - b. Arabian Horse Association (AHA) or any World Arabian Horse Organization (WAHO) member registry (must be purebred Arabian recorded with AHA or WAHO).

- c. The Jockey Club (Thoroughbred) or any Jockey Club approved international registry (must be purebred Thoroughbred recorded with the Jockey Club); or
- 3. The other parent registered with one of the following ApHC-approved national or multinational Appaloosa registries and possessing an ApHC International Registration Incentive Program certificate:
 - a. Associação Brasileira de Criadores de Cavalos, Appaloosa Horse Club Brazil (ABCCA),
 - b. Australian Appaloosa Association Ltd., (AAA)
 - c. The Appaloosa Horse Association of New Zealand, (ApHANZ) Stud-book Registry only. (The Appaloosa Horse Association of New Zealand Non-Studbook Registry is not an ApHC-approved national Registry).
 - d. Appaloosa Horse Breeders Society of South Africa (AHBSSA) Main Registry only.
 - e. Asociación del Caballo Appaloosa de Mexico, (ACAM)
 - f. Panama Appaloosa Horse Club
 - g. **Appaloosa Horse Club of New Caledonia (ApHC NC)**
 - h. **Appaloosa Horse Club of the United Kingdom (ApHC UK) Horses must be registered in 'B' Registry.**

B. A Certificate of Registration with the registry of either the Australian Appaloosa Association Ltd. (AAA), the Appaloosa Horse Breeders Society of South Africa (AHBSSA), or the Appaloosa Horse Association of New Zealand, (ApHANZ). The Certificate of Registration shall be screened for authenticity and ApHC eligibility by such approved national Appaloosa registry and then submitted to the ApHC Registrar for eligibility determination.

205. HORSES NOT ELIGIBLE FOR REGISTRATION

- A. No horse shall be registered with the ApHC that, bears artificial characteristic(s) and/or artificial coat pattern(s).
- B. No horse shall be registered with the ApHC that has draft, pony, Pinto, or Paint breeding.
- C. No horse, except a horse whose parentage has been verified through DNA testing that both parents have an ApHC registration classification, shall be registered or retain registration with the ApHC that has:
 - 1. Continuous leg marking(s) which exceed the top of the forearm(s) or the top of the gaskin(s); and/or
 - 2. White marking(s) on the head exceeding a line around the throat latch and behind ear(s); and/or
 - 3. White marking(s) on the body, including but not limited to the neck, shoulder, girth, barrel, abdomen, hip, thigh and gaskin which are continuous, uninterrupted, longer than six (6) inches (15.2 cm) and separate from an Appaloosa coat pattern, if an Appaloosa coat pattern is present and visible, and which marking(s) do not blend into the base color of the horse.
 These types of markings usually have a solid line that does not blend into the base color and are usually observed in conjunction with underlying non-pigmented skin.

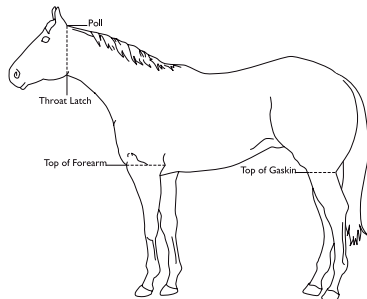

- D. Deceased horses are ineligible for registration.
- E. Horses resulting from one parent that is registered with non-breeding stock papers with an approved breed association are not eligible for registration.
- F. A mature Appaloosa (5 years or older - age computed as of January 1) must stand not less than 14 hands unshod (hand being 4 inches or 10.2 cm).
- G. Any horse that has been registered by the ApHC and is subsequently determined to have been registered improperly shall have its Certificate of Registration cancelled under these rules, except as otherwise expressly provided under these rules.
- H. No horse that is produced from cloning shall be registered with the ApHC.

206. GENETIC DEFECTS AND UNDESIRABLE TRAITS

- A. The conditions listed below and commonly considered undesirable traits or genetic defects by the board of directors shall be indicated on the Certificate of Registration for horses foaled on or after the indicated date, once the condition is known. One or more of these conditions does not prevent a horse from being used as breeding stock or from participating in ApHC-approved events subject to rules of the individual event.
 - 1. Parrot Mouth - either overshot or undershot and is defined by the American Association of Equine Practitioners as "no occlusal contact between the upper and lower central incisors." Designation effective for foals born on or after January 1, 2000.
 - 2. Cryptorchid - meaning both of the testicles have failed to normally descend into the scrotum by three years of age. Designation effective for foals born on or after January 1, 2000.
 - 3. Monorchid - meaning that one of the testicles has failed to normally descend into the scrotum by three years of age. Designation effective for foals born on or after January 1, 2000.
 - 4. A horse with white markings with underlying light skin beyond any of the following described lines shall be eligible for registration with the ApHC and to retain registration with the ApHC only if parentage is (or has been) verified through DNA testing through an ApHC-approved laboratory as both parents having an ApHC registration classification:
 - a. Continuous leg marking(s) that exceed the top of the forearm(s) or the top of the gaskin(s); and/or
 - b. White marking(s) on the head exceeding a line around the throatlatch and behind ear(s); and/or
 - c. White marking(s) on the body, including but not limited to the neck, shoulder, girth, barrel, abdomen, hip, thigh and gaskin that are continuous, uninterrupted, longer than six (6) inches (15.2 cm) and separate from an Appaloosa coat pattern, if an Appaloosa coat pattern is present and visible, and which marking(s) do not blend into the base color of the horse. The following notification shall be placed on the Certificate of Registration of any such horse exceeding these markings and/or limitations: "This horse has white markings designated under ApHC rules as an undesirable trait." Any such horse whose Certificate of Registration is noted with such white markings designation is ineligible to compete in any halter class at ApHC-approved and/or -sponsored events.
 - 5. Hyperkalemic Periodic Paralysis (HYPP) - meaning a muscular disease caused by hereditary genetic defect that leads to uncontrolled muscle twitching or profound muscle weakness, and in severe cases, may lead to collapse and/or death. According to research, this condition exists in certain descendants of the stallion Impressive, AQHA registration number 0767246.
 - a. The ApHC recommends testing of any horse known to have an ancestor carrying the HYPP gene, designated under ApHC rules as a genetic defect, to confirm the presence or absence of this gene.
 - b. ApHC-eligible foals resulting from AQHA-registered stallions and mares born on or after January 1, 2007 and having HYPP status of NH or HH will be required to be HYPP tested at the same time they

are parentage verified and to have their HYPP status designated on their ApHC Certificates of Registration. Further descendants of NH or HH ApHC-registered horses will also be required to be HYPP tested/Parentage Verified and have that status designated on their ApHC Certificates of Registration.

207. REGISTRATION PROCEDURES

- A. The owner or recorded lessee of the dam at the time of foaling is responsible for registration of the foal and will be listed on the Certificate of Registration as the first owner of said foal.
- B. The owner of the horse being registered must be a current year member in order to receive reduced registration rates. If there is a joint ownership and one of the owners is an active member, reduced registration rates will apply.
- C. In cases of deceased owners, see requirements under DECEASED OWNERS.
- D. The application for registration shall be properly completed and signed. The registration application must be accompanied by the breeder's certificate, required photographs and registration fee. (See Fee Schedule.)
- E. The registration application form requires the registration names and numbers of both the sire and dam.
- F. When the sire is registered with the ApHC or any approved breed association and not owned by the applicant, a properly completed and signed breeder's certificate must accompany the application for registration. See BREEDER'S CERTIFICATE.
- G. An Appaloosa not domiciled in the U.S.A. may be registered with the ApHC provided the horse meets all ApHC registration requirements.

208. APPROVED BREED LISTING

A. A one-time listing fee and a photocopy of the front and back of the Certificate of Registration is required for all stallions and mares registered with approved breed associations and being used for breeding purposes in the ApHC. Stallions must be listed prior to the filing of their Stallion Breeding Report. Mares must be listed prior to the registration of their foals in the ApHC. Failure to list a stallion or mare may result in suspension per these rules. Listing applications are available at no charge, upon request, through the ApHC.

B. To be eligible as a parent based on registration with an ApHC-approved breed association, a horse must not exhibit white coloration beyond the currently approved white limitations of the ApHC.

209. APPROVED BREED OWNERSHIP CHANGES

A. As to subsequent registration applications for offspring, if the application indicates an ownership change of the approved breed horse, an additional photocopy of both sides of its Certificate of Registration showing such change in ownership must be filed with the ApHC.

210. REQUIRED PHOTOGRAPHS

- A. Four (4) current color photographs must be submitted along with the application for registration. Photographs should include both sides, a direct face, and a rear view, clearly showing the markings on the head, body and all legs, and depicting the presence, if any, of one or more of the four identifiable Appaloosa characteristics: 1. Coat Pattern; 2. Mottled Skin; 3. White Sclera; and 4. Striped Hooves.
- B. Besides the required photographs, additional photographs may be submitted which would aid in the evaluation of the horse's coat pattern, markings and/or identifiable Appaloosa characteristics.
- C. All scars and brands appearing on a horse should be shown on the Certificate of Registration. Close up photographs of such brands and/or scars must also be submitted.
- D. The burden of proving eligibility for a particular registration classification rests entirely with the applicant.

- E. Photographs become the property of the ApHC and may not be returned.
- F. Label all photographs with date foaled, sex of foal, dam's name and registration number.
- G. The photographs required for registration are reproduced on the back of the Certificate of Registration. Therefore it is to the owner's advantage to send good, clear photographs. Self-developing photos are not recommended. Photographs larger than 4x6 (10.2 cm x 15.2 cm) are not acceptable. Computer-generated photographs must be at least 300 DPI (Dots Per Inch) and printed on photo-quality paper. The ApHC reserves the right, at its discretion, to require additional photographs of better quality.

211. NAME CHOICES

- A. Each animal for which registration is applied must be given an acceptable name which does not conflict with the name of any other animal registered with the ApHC, either living or dead and does not conflict with any previously reserved breeder, bloodline, or ranch names listed below. The following names are not eligible for use: (a) if they consist of more than twenty (20) letters and spaces; (b) end in filly or colt; (c) are names of famous horses; (d) are similar in spelling to names already in use; (e) are names of famous or notorious people unless their notarized consent is filed with the ApHC; (f) are suggestive or which have vulgar or obscene meanings; (g) are similar in pronunciation to any of the above; (h) numbers, including Arabic and Roman, punctuation marks such as apostrophes or hyphens and special characters such as dollar signs or percentage signs may not be used.
- B. Reserved names. ApHC has discontinued the reservation of breeder, bloodline and ranch names. Following is a list of previously-reserved breeder, bloodline, and ranch names and the name and registration number of the horse or the name of the ranch to which it refers:

Apache (Apache F730)
Beau (Beau Rondo, F4218; Bluebird B., F1687; Buttons B., F1681; Pale Moon B., F2064; Quavo B., F2404 (or an ApHC-registered horse whose name contains the word Quavo); Strawboss B., T915)
Bright (Bright Eyes Brother, F3047)
Buttons (Buttons B., F1681)
Chinook Simcoe's Chinook, F1610)
DF (or) D.F. (ranch name, David Feagin)
Dominion (ranch name, Creswell Farms, J. Schwerin)
Dot (cannot be used as complete word, only as part of a word, Dotted Swiss)
El Dorado (ranch name, Fred Olds)
Happy (ranch name, Happy Smith)
Minidoka (ranch name, L.W. Moore)
Sunday (Sunday Pants, #2509)
Tejas (ranch name, Oran Scarlett)

Without written permission (a notarized statement from the person reserving the name), the above-listed reserved names cannot be used unless the horse specified above is listed in the pedigree or the horse is registered by the owner and/or authorized agent of the ranch.

Rules 212-215 are not assigned

216. HARDSHIP REGISTRY

- A. Geldings and spayed mares which do not meet pedigree requirements or are of unknown pedigree will be accepted for registration if they otherwise meet the requirements for Regular registration and are not ineligible for registration as stated in HORSES NOT ELIGIBLE FOR REGISTRATION. Hardship registration applications are available, at no charge, through the ApHC.

217. INCORRECT APPLICATIONS

- A. An incorrect or incomplete application for registration will be returned to the applicant. The fee will be retained until the returned application is resubmitted and, if not received within 60 days, only the fee will be returned, minus an office charge.
1. All correspondence for additional requirements and information will be initially directed to applicant.
 2. A new application is required on horse registrations in which there is a change in the sire or dam, a different foaling year, filled out in pencil, not properly signed or no breeder's certificate. An office charge will be assessed.

218. PROCESSING FEES

- A. All fees are based on date postmarked or date fax is accepted by ApHC whichever is earlier (postal meters not accepted).
- B. An office charge will be assessed on all registration work that is not processed to completion.
- C. The ApHC recognizes two types of rush processing requests.
1. 10 day rush. Registration work is processed within ten (10) working business days after receipt in ApHC office.
 2. 48 hour rush. Rush work is processed within 48 hours after receipt in ApHC office.
 - a. In order for either type of rush work to be recognized by the ApHC, the following requirements must be met:
 1. A rush fee for each registration application or piece of work, in addition to the regular fees, must accompany the application or work.
 2. Envelopes must be clearly marked as RUSH, to avoid delays in processing.
 3. Rush fees are non-refundable and non-transferable. In the event that registration work cannot be processed due to circumstances beyond the control of the ApHC, the rush fee shall not be refunded.
 4. If you wish to have processed work returned by special post, i.e. next day UPS, the additional postage fee or pre-paid envelopes must also be submitted.
- D. Failure by any person to acknowledge any ApHC correspondence relative to the registration or transfer of any horse, or any other related ApHC business, will result in that file being closed and all fees being forfeited. After the first request, a final notice will be sent prior to closure of the file. File will not be closed sooner than 60 days after first request.
- E. If a file has been closed for any reason, the following procedure is required to re-open the file:
1. Payment of the current fees due, including membership, based on date of re-opening file.
 2. Submission of any documents returned to customer, or initially lacking, if any, to complete the work when it was originally submitted.

219. STALLION BREEDING REPORT

- A. Owners of all stallions registered with the ApHC or an approved breed registry and which are used for ApHC breeding purposes must file a yearly stallion breeding report postmarked on or before November 30 of the breeding year to avoid late fees. (June 30 for stallions standing in Southern hemisphere.) Until the report is filed the resulting foals cannot be registered.
- B. The stallion breeding report must list all mares exposed to that stallion including the mares owned by the stallion owner/lessee.
- C. All stallion breeding reports must be accompanied by a non-refundable filing fee. (See Fee Schedule.) If stallion breeding reports are submitted without fees, the ApHC will not file the report, and it will be returned to sender. An additional late fee will be assessed for filing the stallion breeding report after

November 30 of the year of breeding. (June 30 for stallions standing in Southern hemisphere.)

- D. A separate report must be filed for each stallion for each year. Blank stallion breeding reports are available at no charge, upon request, from the ApHC.
- E. All stallion breeding reports shall include mares exposed to transported semen whether or not a mare conceives. Said stallion breeding report will distinguish between natural breeding (hand or pasture), artificial insemination, and transported cooled semen and frozen semen.
- F. Persons using a retained semen rights retention permit must file a stallion breeding report listing mares bred using the stored frozen semen.
- G. If a stallion is leased, the stallion owner must file a properly completed and signed lease agreement with the ApHC. Lease forms are available through the ApHC.
- H. If the mare is leased, a properly completed and signed lease agreement must be on file with the ApHC. The lessee is considered the breeder if mare is leased at the time of breeding.
- I. If someone other than the recorded owner or recorded lessee of the stallion is signing the stallion breeding report, a properly completed and signed authorization allowing such signatures to be accepted during the indicated breeding dates must be on file with the ApHC. Authorization forms are available at no charge, upon request, from the ApHC.
- J. If an owner dies, a representative of that owner must comply with the requirements of ApHC rules regarding Deceased Owners. See requirements under DECEASED OWNERS.
- K. The stallion owner must have all the necessary and correct information on the mares listed on the stallion breeding report. A photocopy of the Certificate of Registration should be given to the stallion owner at the time of service. A registration will be held up if the stallion owner does not list the correct information on the stallion breeding report.
- L. To add a mare to a stallion breeding report which has been sent to the ApHC, a separate report must be completed, and submitted to the ApHC along with the appropriate fee. (See Fee Schedule.) Persons using a retained semen rights retention permit may not add mares to a stallion breeding report previously filed by stallion owner of record, or another owner of semen rights retention permit(s).
- M. All stallions by submission of their stallion breeding report for any breeding year must be DNA tested and the results must be filed with the ApHC.
- N. Under a grandfather clause, stallions 10 years old or older as of January 1, 1990 and breeding 5 mares or less need not be typed unless they are breeding by artificial insemination, then the ApHC must have the stallion's DNA on file.

220. BREEDER/BREEDER'S CERTIFICATE

- A. The recorded owner or lessee of the dam at the time of service is the breeder and shall be listed as the breeder on the Certificate of Registration.
- B. When a frozen embryo is implanted, the original purchaser of the frozen embryo permit shall be listed as the breeder on the Certificate of Registration.
- C. If the sire is registered with the ApHC, or an approved breed association and not owned by the applicant, a breeder's certificate completed and signed in ink by the owner or record lessee of the stallion must accompany the foal's application for registration with the following exception:
1. When a properly signed frozen embryo permit is used to register a foal, no additional breeder's certificate is required. The breeder's certificate requirements were met when application to purchase the frozen embryo permit was made.
- D. The breeding must also be listed on a stallion breeding report on file with the ApHC.
- E. When a semen rights retention permit is used to register a foal, the ApHC shall require only the signature of permit owner on the permit to verify the service of

the sire. Recorded owner of dam at the time of breeding must sign the appropriate breeder's certificate on the registration application.

- F. No person shall make any alterations to information on breeders' certificates. A breeder's certificate on which information has been changed may not be accepted by the ApHC.

221. ARTIFICIAL INSEMINATION

A. Artificial insemination (AI), including cooled **transported and** frozen semen, may be used, and resulting foals are eligible for registration with the ApHC if the following conditions are met:

1. A properly completed and signed stallion breeding report shall be filed with the ApHC indicating mares bred by artificial insemination including **cooled transported and** frozen semen.
2. A properly completed and signed breeder's certificate must accompany the foal's application for registration.

B. COOLED TRANSPORTED AND FROZEN SEMEN::

1. The use of proper technology for shipping and using **cooled transported and frozen semen** is the responsibility of the owners of the stallion and the mare involved. The ApHC, its Directors, Officers, and employees assume no responsibility for **collection, shipment, quality of semen, or** the success or failure of the breeding process. Breeding contracts are contracts between the stallion and mare owners, lessees, or authorized agents only.
2. Ownership of any semen frozen by the previous owner/lessee must be resolved between the seller and the buyer.
3. If a stallion is leased, the use of the frozen semen by the lessee is restricted to the time period of the lease (beginning and ending dates).
4. Foal Registration:
 - a. DNA samples of the foal and mare must be collected and sent to the approved laboratory for typing prior to application for registration of the foal.
 - b. In addition, to comply with other registration requirements under these rules, the owner, lessee, or authorized agent of the dam at the time of foaling, shall cause the verified laboratory or DNA test results of the affected dam and foal to be submitted to the ApHC.
 - c. Foal registration will only be made if the foal's DNA is compatible with the DNA of the sire and dam.
5. Denial of Registration:
 - a. The ApHC reserves the right to deny registration of any foal conceived by means of **cooled transported or frozen** semen if all ApHC rules and regulations are not adhered to.

222. SEMEN RIGHTS RETENTION PERMIT

A. In the event a stallion owner wishes to sell a stallion, but retain rights to use frozen semen, s/he may purchase frozen semen rights retention permit(s) from the ApHC. The application for purchase must be on a form provided by ApHC and proper fees must accompany application. (See Fee Schedule)

1. Only the recorded owner or lessee of the stallion may purchase frozen semen rights retention permit(s). Only signatures of the recorded owner or lessee of the stallion shall be accepted on the application(s).
2. Once a stallion is sold, a former owner or lessee cannot purchase additional frozen semen rights retention permits from the ApHC.

B. Each of the retained frozen semen rights permits purchased may be used as the stallion breeder's certificate for the registration of only one foal.

1. ApHC will record the number of outstanding permits for each individual stallion and that number will be a matter of public record.
2. It is the ultimate responsibility of a prospective buyer to confirm with the seller, the number of outstanding permit applications not yet recorded on ApHC records as of the date of sale.

C. The ownership of the retained frozen semen rights permits may be transferred. (See Transfer of Ownership Rules and Fee Schedule.)

1. The ApHC shall record each transfer of ownership of the permit. The rules of transfer of ownership of a horse shall apply to frozen semen rights retention permits, except the request to transfer ownership of the permit shall be accompanied by the retained frozen semen rights permit instead of the Certificate of Registration.

D. Purchaser of the retained frozen semen rights permit is responsible for filing the appropriate stallion breeding report as required by ApHC rules and paying the requisite filing fees.

223. FROZEN EMBRYO RIGHTS RETENTION PERMIT

A. In the event a mare owner wishes to sell a mare, but retain rights to use frozen embryos, s/he may purchase frozen embryo rights retention permit(s) from the ApHC. The application for purchase must be on a form provided by ApHC and proper fees must accompany application. (See Fee Schedule)

1. Only the recorded owner or lessee of the mare may purchase frozen embryo rights retention permit(s). Only signatures of the recorded owner or lessee of the mare shall be accepted on the application(s).
2. The stallion owner or lessee at the time of breeding must also sign the frozen embryo rights retention permit application.
3. This permit when used to register a foal shall serve as both the stallion breeding report and the breeder's certificate.
4. Once a mare is sold, a former owner or lessee cannot purchase additional semen rights retention permits from the ApHC.

B. Each of the frozen embryo rights permits purchased may be used for the registration of only one foal.

1. ApHC will record the number of outstanding permits for each individual mare and that number will be a matter of public record.
2. It is the ultimate responsibility of a prospective buyer to confirm with the seller, the number of outstanding permit applications not yet recorded on ApHC records as of the date of sale.

C. The ownership of the frozen embryo rights retention permits may be transferred. (See Transfer of Ownership Rules and Fee Schedule.)

1. The ApHC shall record each transfer of ownership of the permit. The rules of transfer of ownership of a horse shall apply to frozen embryo rights retention permits, except the request to transfer ownership of the permit shall be accompanied by the retained semen rights permit instead of the Certificate of Registration.

D. When a frozen embryo rights retention permit is used to register a foal, the owner of the permit shall sign the registration application as the owner at time of foaling.

224. EMBRYO/OOCYTE TRANSFER

A. A horse foaled by a mare which is not its genetic dam, but transferred to her by embryo/oocyte transfer technique, shall be eligible for registration. In addition to other ApHC registration rules, the offspring shall not be eligible for ApHC registration unless:

1. Prior to intended collection of the fertilized egg, record owner or lessee has notified ApHC in writing of its intention to attempt an embryo/oocyte transfer and has paid the proper enrollment fee as set forth in the fee schedule. Upon good cause, in its sole discretion, the ApHC may accept late enrollment notification. For mare enrollments received and accepted by the ApHC after collection of the embryo/oocyte, but prior to foaling, a late fee as set forth in the fee schedule will be assessed, in addition to other required fees. For mare enrollments received and accepted by the ApHC after foaling, a late fee as set forth in the fee schedule will be assessed, in addition to

other required fees. This enrollment must be made each year that a transfer is to be performed, and once made, the fee is not refundable, nor can any substitution be made.

2. Pedigree is verified through genetic testing of foal, sire and donor mare; and by such other testing as ApHC reasonably deems necessary to verify the validity of the genetic testing, all expense of which shall be the registration applicant's.
 3. Prior to transport, in accordance with ApHC-approved procedures, of an embryo/oocyte from the premises where the donor mare was located at the time of removal of an embryo/oocyte from her for use in recipient mare at another location, notice of intention to transport the embryo/oocyte shall be given ApHC in connection with advanced notice of collection specified above. Any implantation of transported embryo/oocyte for which such notice is given must occur within 24 hours of its removal from the donor mare or the offspring will not be eligible for registration.
- B. The enrollment notice must be sent by certified mail, return receipt requested, to preserve for the record owner or lessee of the donor mare the only acceptable proof to ApHC of timely compliance with advance notice of collection specified above, if such proof is requested.
 - C. If a mare is enrolled with ApHC for embryo/oocyte transfer, but the procedure is not attempted regarding the mare in the designated year, to avoid the necessity of genetic testing for parentage verification, ApHC must be notified in writing by December 31 of the designated year that the owner has elected not to attempt embryo/oocyte transfer. Without such notice, a foal produced the following year by such an enrolled mare is not eligible for registration without genetic testing for parentage verification.
 - D. When a registerable foal is produced by embryo/oocyte transfer, such fact will be listed on its registration certificate.
 - E. ApHC may inspect the premises and practices of any party using or intending to use embryo/oocyte transfer procedures. An ApHC representative and/or ApHC approved veterinarian may be present during the collection and transfer procedures at the ApHC's discretion.
 - F. The burden of verifying true parentage is the registration applicant's, and any question of parentage shall be resolved against registration of a horse carried by a recipient mare through embryo/oocyte transfer.

225. DNA TESTING

- A. All foals are eligible to be parentage verified and all other horses are eligible to be identified through DNA testing on the basis of written analysis filed with the ApHC from an ApHC-approved laboratory, using ApHC-approved testing procedures. Upon necessary filings, such foal's Certificate of Registration shall be issued or re-issued with the designation as "Parentage Verified". In the event any foal is designated as "Parentage Verified", no other method of identification is required under these rules. In the event any other horse is identified through DNA analysis filed with the ApHC, no other method of identification is required under these rules. Test results for genetic conditions, if such test(s) is/are drawn from a DNA sample that is also parentage verified, may be filed with the ApHC and such test results may be designated on the horse's Certificate of Registration. All fees and procedures for issuance of corrected certificates will be required where applicable.
- B. Any horse for which a Performance Permit is sought must be parentage verified through DNA analysis by an ApHC-approved laboratory as required by ApHC rules.
- C. If a mare is exposed to two or more stallions in less than 45 days, a DNA test of the stallions, mare and resulting foal will be required before the resulting foal can be registered, with the owners paying the cost of the testing. If the correct sire cannot be determined as a result of the testing, the name of each stallion must be given as the sire of any resulting foals and a breeder's certificate shall be

supplied with respect to the services of each stallion. The charge for testing will be the actual and necessary cost for performing each test.

- D. If a mare is bred naturally and by transported semen within 45 days, resulting foals will be required to be parentage verified through DNA testing prior to being registered.
- E. The ApHC registrar is authorized to randomly and/or selectively require parentage verification through DNA and/or other genetic testing of ApHC-registered horses.
- F. In addition to other ApHC-registration rules, a foal born in a year shown below is not registerable unless the mare of said foal, born during or after the year shown in the column next to said foal's birth year, has filed with the ApHC the results of said mare's DNA testing from an ApHC-approved laboratory using ApHC approved testing procedures.

Foal's Birth Year	Mare's Birth Year
2004	1995 and after
2005	1994
2006	1993
2007	1992
2008	1991
2009	1990 and prior years

- G. The owner of any horse, for which application is made for registration and which cannot be parentage verified due to unavailability of DNA type of sire or dam shall have the right to make written request that the ApHC Registrar consider allowing use of alternative verification method(s), and the ApHC Registrar, in the Registrar's sole discretion, may determine that use of alternative verification method(s) are acceptable to the ApHC in the registration of any such horse.
- H. In order to protect innocent third-party owner(s) of offspring that are the product of a breeding of previously eligible parents that took place prior to the date of cancellation of the Certificate of Registration of such parent or parents, such offspring are eligible for registration, however, any previously issued Certificates of Registration for such offspring shall be recalled to designate the pedigree behind the ineligible or cancelled parent(s) as "Unknown."

Rules 226 and 227 are not assigned.

228. INTERNATIONAL REGISTRATION INCENTIVE PROGRAM

- A. To be eligible for IRIP registration a horse must meet the following requirements:
 1. The horse must be registered with an ApHC-approved national or multinational Appaloosa registry.
 2. The horse must not be ineligible for registration in accordance with ApHC Rule 205, HORSES NOT ELIGIBLE FOR REGISTRATION.
 3. The current owner of the horse, as shown on the horse's Certificate of Registration issued by an ApHC-approved national or multinational Appaloosa registry, must submit to the ApHC a properly completed application, using an ApHC-approved form, and include:
 - a. Copies of both sides of an ApHC-approved national or multinational Appaloosa registry Certificate of Registration for the horse,
 - b. Four (4) current color photographs clearly showing a front view, both sides and rear view of the horse, and
 - c. Proper fees, as set forth in the ApHC Fee Schedule. Applications submitted without proper fees will be returned to the applicant.
 4. The ApHC Registrar may require an inspection and/or examination of any applicant horse. Prior to inspection and/or examination, the owner shall pay actual and necessary expenses for the inspection and/or examination. Upon

- request, the owner shall transport the horse to a convenient location to permit the inspection and/or examination. Said application shall be rejected if the owner of the horse refuses to permit the inspection and/or examination.
5. The burden of proof of eligibility for approval of said application rests solely with the owner/applicant.
- B. The ApHC Registrar reserves the right to disapprove the application of any horse for IRIP registration, which does not meet applicable ApHC registration requirements.
 - C. The ApHC will not be liable for any error or misrepresentation on an application or any subsequently issued IRIP Certificate of Registration. In case of such error or misrepresentation, the ApHC reserves the right to suspend, revoke, cancel or correct the issued certificate and take any other action in accordance with ApHC rules.
 - D. Horses approved for IRIP registration are not guaranteed issuance of the same name for ApHC registration purposes as registered with the ApHC-approved national or multinational Appaloosa registry. All name choices, rules and regulations contained in the ApHC rules apply.
 - E. In instances when a horse meets ApHC Regular (#) or Non-characteristic (N) registration requirements contained in ApHC rules and as shown by the Certificate of Registration issued by an ApHC-approved national or multinational Appaloosa registry, said horse shall be granted Regular (#) or Non-characteristic (N) registration classification upon meeting all requirements for re-registration under ApHC rules, including payment of appropriate fees.
 - F. IRIP Transfers:
 1. All transfers of ownership must be current and recorded on the Certificate of Registration issued by an ApHC-approved national or multinational Appaloosa registry.
 2. Transfers completed prior to application for IRIP registration will be recorded with the ApHC only if all required transfer fees are paid as set forth in the ApHC Fee Schedule.
 3. If an owner wishes to have all previous transfers recorded on the back of the IRIP Certificate of Registration, appropriate fees must be submitted along with the application for IRIP registration. It is not necessary to submit properly completed transfer reports to the ApHC, as transfers of ownership will be verified from the horse's Certificate of Registration issued by an ApHC-approved national or multinational Appaloosa registry.
 4. Upon issuance of an IRIP Certificate of Registration, the ApHC will not allow previous transfers to be recorded.
 5. The ApHC will issue an IRIP Certificate of Registration in the most current owner's name as recorded on the Certificate of Registration issued by an ApHC-approved national or multinational Appaloosa registry.
 6. The IRIP Certificate of Registration will be returned to the most current recorded owner of the horse, unless said owner includes a signed statement instructing the ApHC to send the IRIP certificate to another party.

229. PERFORMANCE PERMIT

- A. Application requirements for registered Appaloosa horses for which a Performance Permit is sought are as follows:
 1. To be eligible to apply for a Performance Permit, the horse must be registered with the ApHC in the non-characteristic (N) category.
 2. The owner is required to submit to the ApHC, the original Certificate of Registration, along with a properly completed and signed Performance Permit application, four current photographs of the horse including both sides, a direct face and rear view, and proper Performance Permit fees in accordance with the applicable fee schedule.
- B. Application requirements for horses pending registration for which a Performance Permit is sought are as follows:
 1. A Performance Permit may be applied for upon initial application for registration of a horse.
 2. The owner of the horse should have good reason to expect the horse would receive a non-characteristic (N) classification when registered.
 3. Along with the requirements for registration, the owner must submit a properly completed and signed Performance Permit application and the proper Performance Permit fee in accordance with the applicable fee schedule.
- C. Non-characteristic (N) horses will be issued a Performance Permit if they meet the following requirements:
 1. Any horse for which a Performance Permit is sought must be DNA tested by an ApHC approved laboratory and the results filed with the ApHC.
 2. The dam of any horse for which a Performance Permit is sought must be DNA tested by an ApHC approved laboratory and the results filed with the ApHC.
 3. The sire of any horse for which a Performance Permit is sought must be DNA tested by an ApHC approved laboratory and the results filed with the ApHC.
 4. Any horse for which a Performance Permit is sought must be parentage verified through DNA analysis by an ApHC approved laboratory to the satisfaction of the ApHC Registrar to be the foal of the sire and dam listed in the ApHC records.
 5. The owner must pay all expenses for the Performance Permit application and all parentage verification testing related to the applicant horse.
 6. Notwithstanding the above, the ApHC CEO, with approval of the ApHC Executive Committee, may determine that a Performance Permit be issued to a Non-Characteristic (N) horse if the horse was born prior to 2007 and cannot be parentage verified.
- D. When the parentage of any such horse has been verified and the requirements of this rule are met to the satisfaction of the Registrar, the Registrar will amend the Certificate of Registration as hereinafter provided, showing the horse's parentage has been verified and the Performance Permit has been issued. The Performance Permit designation is in effect for the life of the horse, regardless of ownership changes of the horse.
- E. Non-characteristic (N) horses which have applied for and received a Performance Permit, and which are used for breeding purposes, must be bred to a Regular (#) registered Appaloosa to make the resulting foal eligible for registration with the ApHC.
- F. The decision of the Registrar on all Performance Permit applicant horses is final, however, the owner of a horse shall have the right to appeal in accordance with the Registration Appeal procedures.
- G. Enrollment in the Performance Permit program is entirely voluntary.
- H. The burden of proving a horse's entitlement to be issued a Performance Permit rests solely with the applicant.
- I. If the Registrar determines that DNA testing and/or any related identification information provided to the ApHC disproves parentage as set forth on that horse's Certificate of Registration, the horse's Certificate of Registration will be cancelled. If a horse for which a Performance Permit is sought fails to meet the requirements for a Performance Permit and that horse's Certificate of Registration is not otherwise cancelled under ApHC rules, then that horse's non-characteristic (N) Certificate of Registration will be returned to owner.
- J. The ApHC reserves the right to suspend, revoke or correct any Certificate of Registration issued with a Performance Permit and the entry of the named horse in accordance with the Protest, Inspection and Appeal Procedures set forth in the *Official Handbook* of the ApHC.

- K. Any non-characteristic (N) horse issued a Performance Permit by the ApHC is eligible to participate in ApHC-approved events and, if qualified under ApHC rules, in ApHC-sponsored events.

Rules 230-235 are not assigned.

236. FOUNDATION PEDIGREE DESIGNATION

- A. To be eligible for the FPD program, the horse must be registered with the ApHC. This option may also be done concurrently with the application for registration. A horse must also meet the following criteria:

1. Beginning in 2009, then every ten years thereafter, the minimum percentage of FPD eligibility will increase incrementally by requiring one additional horse in the preceding four (4) generations of the applicant horse be registered with the ApHC; that is 23 out of 30 beginning in 2009, then 24 out of 30 beginning in 2019, and so on.

Year	Percentage	ApHC-Registered Ancestors Required
2009	77%	23
2019	80%	24
2029	83%	25
2039	87%	26
2049	90%	27
2059	93%	28
2069	97%	29
2079	100%	30

2. There must be a minimum of three (3) of these ancestors on both sire and dam sides of the pedigree.
 3. Any and all 'F' numbered horses within the preceding four (4) generations of the applicant horse's pedigree are to be considered 100% for FPD purposes, regardless of the parentage of the 'F' numbered horses.
 4. Horses may enter the FPD program at the percentage level requirements that were in place at the time of their birth. For example, horses born in or prior to 2003 may enter the FPD program at 50 percent; horses born in 2004 to 2008 may enter the FPD program at 73 percent, and so on.
- B. The FPD application shall be properly completed and signed. The application must be accompanied by the Certificate of Registration or application for registration, plus four current photographs of the animal showing both complete sides, including all four leg markings, direct face and rear view and proper fees. (See Fee Schedule)
- C. When the requirements are met to the satisfaction of the Registrar, the Certificate of Registration as hereinafter provided will be issued showing this pedigree has been approved by the Registrar for the FPD.
- D. The decision of the Registrar on all FPD applicants is final; however, the owner of the horse shall have the right to appeal in accordance with the Registration Appeal Procedures.
- E. Enrollment in this program is entirely voluntary
- F. The burden of proving eligibility for this program rests with the applicant.
- G. The ApHC reserves the right to suspend, revoke or correct the issued Certificate of Registration and the entry of the named horse in accordance with the Protest, Inspection and Appeal Procedures set forth in this handbook.

237. GENERATION ADVANCEMENT PROGRAM (GAP) REQUIREMENTS

- A. To be eligible for the first level (G5) of the GAP, the sire and dam of applicant horse must have four (4) complete generations of ApHC-registered Appaloosa horses in their pedigrees according to ApHC records. There can be no

unknown, unregistered, or non-Appaloosa horses in their four (4) generation pedigrees, no matter where the placing of a Foundation (F) horse with unregistered or undocumented parentage may fall in said pedigrees.

- B. Sire of the applicant horse must be registered with the ApHC and must be DNA tested and the results filed with the ApHC.
- C. Dam of the applicant horse must be registered with the ApHC and must be DNA tested and the results filed with the ApHC.
- D. Applicant horse must be parentage verified via DNA testing through the ApHC and results filed with the ApHC.
- E. At least one parent must be registered with a Regular (#) registration classification.
- F. Only offspring of horses entered in the GAP will qualify for the next level of said program.
1. A G6 level horse results from the breeding of a) two (2) G5 level horses or b) a G5 level horse and a G5 level or higher horse.
 2. Resulting foals only advance one level from the lowest level parent.
- G. ApHC-registered horses that are eligible to show at ApHC approved and/or sponsored events, and which are entered in the GAP evidencing a G5 level or higher, may enter ApHC-approved Foundation Pedigree Designation (FPD) classes in addition to other ApHC-approved classes for which they are eligible.
- H. The GAP application shall be properly completed and signed. The application must be accompanied by the Certificate of Registration or application for registration, plus four current photographs of the animal showing both complete sides, including all four leg markings, direct face and rear view and proper fees. (See Fee Schedule)
- I. When the requirements are met to the satisfaction of the Registrar, the Certificate of Registration as hereinafter provided will re-issued showing the pedigree has been approved by the Registrar for the GAP.
- J. The decision of the Registrar on all GAP applicants is final; however, the owner of the horse shall have the right to appeal in accordance with the Registration Appeal Procedures.
- K. Enrollment in this program is entirely voluntary.
- L. The burden of proving eligibility for this program rests with the applicant.
- M. The ApHC reserves the right to suspend, revoke or correct the issued Certificate of Registration and the entry of the named horse in accordance with the Protest, Inspection and Appeal Procedures set forth in this handbook.

238. CHANGING A PEDIGREE CERTIFICATE (PC)

- A. The Pedigree Certificate and Identification systems have been phased out. Horses with tan Pedigree Certificates may receive an N or Regular Certificate of Registration provided the horse meets lineage requirements as stated in BLOODLINE REQUIREMENTS. The owner must send four current, colored photographs including both sides, a direct face, and a rear view, as well as any close up photographs demonstrating the requirements of Regular registration, along with the scheduled fee to the Registration Department.

239. ADVANCEMENT TO REGULAR REGISTRATION

- A. At the owner's discretion, any horse which has a Breeding Stock, N, or CN Certificate of Registration may be advanced to Regular registration by the owner sending a properly completed advancement form, together with a non-refundable fee, required photographs, and the horse's original Certificate of Registration, to the Registration Department.

1. Required photographs include four current colored photographs, including both sides, a direct face and a rear view, clearly showing all face and leg markings, and coat pattern if present. Close up photographs depicting mottled skin and one other characteristic must be submitted if there is not an Appaloosa coat pattern present.

- B. When the advancement cannot be completed due to discrepancies between photographs submitted with the application for registration, and the photographs submitted for advancement, the Certificate of Registration and all photographs shall be retained in the ApHC until discrepancies can be resolved.
- C. If the ApHC cannot complete the advancement, the Certificate of Registration will be retained in the ApHC and an office charge shall be assessed.
- D. Horses registered as N may be advanced to Regular free of charge if the advancement form, photographs as required above and the Certificate of Registration are received within one year from the date the original Certificate of Registration was issued. If a horse is denied advancement and resubmitted at a later date, the advancement fee will apply.

240. ADVANCEMENT FROM TENTATIVE TO PERMANENT

- A. There are three ways an animal originally registered in the Tentative category can be advanced to the Permanent registry.
 - 1. When the sire and dam of a horse registered in the Tentative category have both been Permanent, the owners should then send the Tentative Certificate of Registration, current colored photographs including both sides, a direct face and rear view and the advance to Permanent fee to the office with a properly completed advancement form.
 - 2. Horses can also be advanced to Permanent by meeting a production requirement. When a stallion has sired 12 Regular registered foals, or a mare has produced three Regular registered foals, it is eligible for advancement to Permanent. The owner would then complete an application for advancement to Permanent and send it to the ApHC with four current colored photographs meeting the registration requirements, the Tentative Certificate of Registration and the advance to Permanent fee. Foals registered under the Breeding Stock provision prior to January 1, 1983, except those with an N preceding the registration number, count toward the production requirements and are eligible to pass to Permanent. Breeding Stock or non-characteristic horses that have an N preceding the registration number must remain Tentative registered. If a stallion or mare is registered at the same time as its foals, the advancement to Permanent fee is still required. Deceased horses which were formerly eligible for Permanent can be advanced to Permanent posthumously. Send the Certificate of Registration and appropriate fee.
 - 3. Stallions that are Tentative registered and later gelded will be transferred to Permanent only if the requirements are met for Regular registration. The same applies to mares that are spayed. The Tentative Certificate of Registration must be returned to the office with a statement that the animal has been altered, the month, day and year of the operation, and four current colored photographs including both sides, a direct face and rear view. A new Permanent Certificate of Registration will be issued. In the case of a Breeding Stock registered stallion's change to gelding, if the photographs submitted do not show the gelding to be recognizable as an Appaloosa, the gelding will receive a non-characteristic Certificate of Registration.

241. CORRECTION OF CERTIFICATE OF REGISTRATION

- A. A corrected Certificate of Registration is one which is issued to indicate a change in color, markings, foaling month, or the removal or addition of scars or brands which previously had been indicated on the Certificate of Registration, or correction of minor errors on the original application for registration. The ApHC office must be provided with the original Certificate of Registration before a corrected Certificate of Registration can be issued.
- B. Correction of an original Certificate of Registration may be obtained by the current recorded owner submitting to the ApHC the original Certificate of Registration, four current photographs of the animal showing both complete sides, including all four leg markings, a direct face and rear view, and proper fees. (See Fee Schedule.)

- C. If the application for a corrected Certificate of Registration contains a discrepancy of such nature as to bring into question the identity of the animal, the Registrar may require inspection of the animal.
- D. If the ApHC cannot complete the correction, the Certificate of Registration will be retained in the ApHC and an office charge shall be assessed.
- E. Upon issuance of a corrected, duplicate, or replacement certificate, the original certificate issued by the ApHC or any previously issued corrected, duplicate or replacement certificate is thereby considered null and void. The certificate considered to be valid and in force will be the certificate with the most current issuance date, except at ApHC sole discretion. Any previously issued certificate not in force at the time of submission to the ApHC may be retained by the ApHC and the individual submitting it may be required to obtain a new certificate by submitting requirements and paying the required fee(s). Failure to surrender invalid certificate may result in possible disciplinary action pursuant to these rules.
- F. It shall be the obligation of the owner to return a Regular Certificate of Registration when the horse no longer meets the registration requirements for Regular registration. The registration of any horse is subject to suspension, revocation, or correction in accordance with the rules of the ApHC.

242. FREE CORRECTIONS

- A. Free corrections will be made only if the inaccuracy is not a result of incorrect information supplied to the Registration Department on the application for registration.
- B. Within 30 days from the date the Certificate of Registration is issued by the ApHC, the owner may return the certificate to the ApHC for correction at no additional charge. Said 30 days will be determined by the date of issuance on the bottom of the Certificate of Registration and the postmark date when the certificate is returned.
- C. The original Certificate of Registration should be accompanied by the necessary documentation for the change, including required photographs, both sides, a direct face and rear view.
- D. Such corrections shall not include change of name from one which has been submitted by the owner.
- E. It is the policy of the ApHC that free corrections will be given only up to six months from the date an inspector corrects and stamps a Certificate of Registration. The stamped Certificate of Registration should be submitted to the ApHC, accompanied by required photographs including both sides, a direct face and rear view.

243. HORSE COLOR CHANGE

- A. If the color of a horse has changed so that the current description does not apply to the Certificate of Registration, the owner is obligated to re-describe the color and markings, send four current photographs, both sides, a direct face, and a rear view, the appropriate fee and the Certificate of Registration to the ApHC.

244. STALLION TO GELDING OR MARE TO SPAYED MARE

- A. When an animal is altered (gelded or spayed), the Certificate of Registration must be returned to the ApHC accompanied by a letter from the veterinarian who performed the surgery or the owner as to the month, day and year and type of surgery performed and the registered name and number of the horse involved. The certificate shall be stamped gelding or spayed mare at no charge and shall be returned to the last recorded owner.

245. OWNER NAME CHANGE

- A. If an owner's name is changed due to a change in marital status, it is not necessary for the Certificate of Registration to show the change. However, it is very necessary that our office be advised of the new name and address as well as the

former name and address. If an owner wishes to have her/his new name appear on the Certificate of Registration, an application for a new Certificate of Registration must be properly completed and signed including four current colored photographs including both sides, a direct face and a rear view, the appropriate fee and the original Certificate of Registration.

- B. If the owner's name appears on a transfer label, on the back of the Certificate of Registration, the change can be made at no charge. Simply return the Certificate of Registration and information regarding the name change.

246. HORSE NAME CHANGE

- A. A horse's name can be changed by the registered owner, only if there have been no get or produce registered to that animal, if it has never started in a recognized race, if it has no performance record or any ACAAP merits, and if its name has not been listed in a Stud Book.
- B. To change the name of an animal, return the Certificate of Registration to the ApHC with the new name choice, see NAME CHOICES, and the name change fee. If the horse is more than one year old, four current colored photographs of the horse including both sides, a direct face, and a rear view are also required.
- C. The new Certificate of Registration will show the former name as well as the new name on the back of the certificate.

247. RE-REGISTRATION CERTIFICATES

- A. Re-registration certificates are those on which there is a change in the sire or dam or a different foaling year. A re-registration certificate requires a new application properly completed and signed, and a notarized affidavit, on a form provided by the ApHC from the owner of the dam at the time of foaling which gives detail as to why the horse was incorrectly registered, and a re-registration fee. In addition, if the foaling year is changed to an earlier year, the difference between the registration fee paid at time of original registration and the amount which should have been paid at that time, must be remitted. All other registration requirements must be met. If the name of the horse is changed in a re-registration, all requirements stated in HORSE NAME CHANGE apply, including the name change fee.

Rules 248-250 are not assigned.

251. DUPLICATE CERTIFICATE OF REGISTRATION

- A. A duplicate Certificate of Registration is a new Certificate of Registration issued when the original has been lost or destroyed. It is issued when sufficient proof of loss and proper identification of the horse has been submitted to the ApHC office.
- B. The ApHC may issue a duplicate Certificate of Registration if the current recorded owner or authorized agent files a properly completed and signed affidavit, duly notarized, stating the circumstances under which the original Certificate of Registration was lost or destroyed and pays the required fee. Affidavits are available through the ApHC. Such affidavit is to be accompanied by four current color photographs of the animal showing both sides, direct face, and rear view.
- C. If the present, actual owner, is not indicated in the ApHC's files to be the record owner, he additionally shall provide the ApHC with a properly completed and signed affidavit from the last recorded owner in order to obtain the duplicate Certificate of Registration. Such affidavit shall set forth the circumstances of the transfer and the identity of the person to whom he delivered the Certificate of Registration.
- D. If the Certificate of Registration was lost by a trainer, or racing official at the track, or other such persons, properly completed and signed affidavits from such other persons should accompany the record owner's affidavit for a duplicate certificate.
- E. If the application for the duplicate Certificate of Registration contains a discrepancy of such nature as to bring into question the identity of the animal, the Registrar may require inspection of the animal.

- F. In order to issue a duplicate Certificate of Registration when the record owner or authorized agent cannot be located to complete an affidavit (after all reasonable efforts by the actual owner and then by the ApHC office), the following items are required:

1. Properly completed and signed transfer reports or acceptable bills of sale reflecting each ownership change beginning with the record owner.
 2. Notarized affidavit signed by each party who had the original Certificate of Registration in his or her possession after the record owner.
 3. A signed statement from actual current owner giving details of his attempts to contact recorded owner.
 4. Four current colored photographs of the horse including both sides, direct face, and rear view.
 5. The required fee for duplicate certificate.
 6. The required fee for each ownership change.
- G. Any person requesting a duplicate Certificate of Registration agrees as a condition to said application and issuance of the duplicate certificate to sign a hold harmless agreement and any other documentation required by the Registrar of the ApHC to hold the ApHC harmless from any suits, claims, or causes of action arising from the ApHC issuing a duplicate Certificate of Registration based on the applicant's request.
 - H. In regard to involuntary transfer of title situations, including, but not limited to, court judgments and stableman's lien or security interest foreclosure, when it is proven to the ApHC's satisfaction that a previous owner is unavailable to submit an affidavit concerning the original Certificate of Registration or refuses to implement the court's judgment by delivering the original Certificate of Registration for transfer, at the ApHC's discretion and in the interest of equity, requirement of affidavit of the record owner may be waived and the current owner deemed eligible for a duplicate Certificate of Registration.
 - I. For any duplicate Certificate of Registration issued pursuant to court judgment, stableman's liens or security interest foreclosures or any other type of legal proceeding, the applicant agrees to provide the ApHC with a hold harmless agreement and statutory documentation and original or certified copies of all legal proceedings had and conducted in support of the application for issuance of the duplicate Certificate of Registration. Failure of the applicant to provide any documentation requested by the Registrar shall result in a refusal to issue the duplicate Certificate of Registration.
 - J. Reference CORRECTION OF CERTIFICATE OF REGISTRATION.

252. REPLACEMENT CERTIFICATE OF REGISTRATION

- A. If a new Certificate of Registration is desired for any reason (i.e., if certificate has become worn or illegible), send a written request for a replacement Certificate of Registration, the old Certificate of Registration, four current colored photographs, including both sides, a direct face, and a rear view, and the appropriate fee.
- B. If the original Certificate of Registration is received in the ApHC office in such condition (for instance, it has been defaced by writing on it or is laminated) that it warrants a new certificate, the record owner may be required to obtain a new certificate by submitting requirements and paying required fee.
- C. Reference CORRECTION OF CERTIFICATE OF REGISTRATION.

253. DECEASED HORSES

- A. When a registered Appaloosa dies, the owner should notify the ApHC including the name, registration number, month, day and year of death and signature of the recorded owner. The original Certificate of Registration need not be submitted to the ApHC. The records will be marked deceased.
- B. When, according to the ApHC's records, a horse has lived thirty years past January 1 of its foaling year, it will be presumed dead and its registration file will be

automatically marked as dead, without necessity of prior notice. The horse is then ineligible for registration of its offspring foaled after that date or for participation in ApHC-approved events. If the horse has not actually died, and its owner wishes to reinstate its Certificate of Registration, the owner may contact the ApHC and provide satisfactory evidence that the horse is alive, which the owner will be required to do on an annual basis.

254. DISPOSAL WITHOUT CERTIFICATE OF REGISTRATION

A. When the owner of any ApHC registered horse sells or disposes of that animal without a Certificate of Registration the owner shall notify the ApHC of the fact and surrender the Certificate of Registration to the ApHC for proper notation.

255. AUTHORIZED SIGNATURES

A. If anyone other than the registered owner or recognized lessee of a horse is authorized to sign any documents, a properly completed and signed notarized authorization form by the owner or recognized lessee, giving specific details such as the authorized person's name and address as well as his signature, and the dates involved, must be on file with the ApHC. Authorization forms are available at no charge, upon request, from the ApHC.

B. In cases of persons, partnerships, corporations, businesses and syndicates, a properly completed and signed notarized authorization form must be on file listing the person or persons who may sign for that entity. The ApHC cannot accept the signatures of anyone other than the registered owner or the lessee as recognized by the ApHC without this authorization. This includes husbands, wives, parents, and children.

C. For a horse covered by a lease, the notice of which has been filed with the ApHC, only the lessee or lessee's authorized agent may sign registration documents.

256. DECEASED OWNERS

A. If an owner dies, the ApHC must receive a certified copy of the Letters of Administration or Letters Testamentary and a certified copy of the Death Certificate before another person's signature can be accepted. Letters of Administration are issued when an estate is administered without a will. Letters Testamentary are issued when a will is probated. In jurisdictions where certified copies of Death Certificates, Letters of Administration or Letters Testamentary are not available, the ApHC may accept other instruments satisfactory to ApHC. In the event there was no formal probate of the estate, an Affidavit of Heirship must be completed by the heirs and notarized. Affidavit of Heirship forms are available through the ApHC upon request.

B. If an owner becomes unable to conduct his business, either an original or copy of a Power of Attorney or a certified copy of any court order appointing a representative for such owner shall be on file at the ApHC before any request of the representative on behalf of said owner will be granted.

257. LEASES

A. For a lease of a horse to be recognized by the ApHC whether for breeding, racing, or showing in open classes, a copy of the lease shall be filed with the ApHC signed by both lessor and lessee and submitted with the appropriate fee.

1. The notice shall provide the effective date of lease and may provide a termination date. Otherwise it may be terminated by written notice, giving the termination date, signed by both lessor and lessee; or by a properly executed transfer report which shows a change of ownership from lessor to lessee and which is signed by the lessor.

2. No additional fee shall be charged for termination whether automatic or by a subsequent notice thereof.

3. During the effective term of the lease, the ApHC will not record subsequent changes in ownership until the lease is terminated, unless the transfer report

shows the lessee as the new buyer. The date of sale in such case will become the date the lease is terminated.

B. If the horse is jointly owned and ownership is designated by "and," all owners must sign as lessor.

C. In regard to ApHC procedures, recording of a lease authorizes a lessee to execute all documents pertaining to the recognized activities of breeding, racing, showing or performance. Enforcement against the lessee of limitations on use of the horse is solely the responsibility of the lessor.

D. Transfer of ownership arising from recognized claiming races will terminate any such lease.

258. SYNDICATES

A. In order for a syndicate to be recognized by the ApHC as owner of one or more horses, the horse(s) must be transferred into the name of the syndicate with the following items:

1. A written report of the transfer to the syndicate name must be completed and signed by the last record owner. This transfer report must be received by the ApHC office, along with the Certificate of Registration and the proper transfer fee.

2. Written authorization shall be provided to the ApHC office (forms available upon request) appointing the syndicate manager and signed by the syndicate manager together with a copy of the syndication agreement and certified copy of minutes of the syndicate meeting appointing the syndicate manager.

B. When or if changes are made in syndicate managers, written notice must be provided to the ApHC office, appointing the new syndicate manager, also signed by the new syndicate manager together with a certified copy of the minutes of the syndicate meeting showing syndicate action to replace the prior syndicate manager. No cancellation of the outgoing manager will be made unless written notice and documentation to this effect is received by the ApHC.

C. The ApHC will not referee disputes between syndicate members. As a condition to issuing Certificates of Registration to a syndicate, the syndicate members agree to hold the ApHC harmless from all suits, claims, causes of action and legal fees as incurred in a dispute as to the operation, administration, ownership, transfer and acquisition of ownership, transfer and acquisition of syndicate horses registered with the ApHC.

D. All syndicate members and/or their duly appointed agent(s) upon supplying proof of current syndicate membership to the ApHC shall be entitled to receive any and all information on file with the ApHC pertaining to the syndicated horses(s) in which they have ownership interest.

Rules 259-264 are not assigned.

265. TRANSFER OF OWNERSHIP

A. As seller, the owner of record at time of sale shall have the responsibility for completion of the written transfer report in its entirety, on a form acceptable to the ApHC, and for delivery of it to the buyer. To satisfy this responsibility, the seller must provide on the transfer report the correct name and registration number of the horse, date of sale, name and address of buyer, and signature and address of seller. The seller shall immediately upon completion of the sale deliver the transfer report, along with the Certificate of Registration, to the buyer along with any other documents required to complete the transfer of ownership. The buyer shall then immediately forward the Certificate of Registration, transfer report and applicable fee, with the status of the buyer determining the fee, to the ApHC. The seller's signature must correspond with the name(s) of the owner(s) according to the ApHC records, unless a notarized statement is on file authorizing an agent's signature on behalf of the seller.

- B. The expense and payment of the required fee shall be a matter of private negotiation between the buyer and seller, and may be paid by either of them, but such fee must accompany the transfer report with the membership of the BUYER determining the applicable transfer fee.
 - 1. For member rates to apply, the buyer's membership must be in effect during the calendar year in which the original request for transfer is received in the ApHC office.
- C. The ApHC will list ownership of jointly owned horses as "or" unless otherwise instructed on the transfer report. This ownership listing requires the signature of only one of the owners on all registration documents.
 - 1. Registration documents include, but are not limited to application for registration, transfer report, breeder's certificate, stallion breeding report, affidavits on behalf of the owner, and lease agreements.
- D. If the joint owners wish to be listed as "and", they must notify the ApHC by so listing on the transfer report. Where "and" is used, the signatures of all owners are required on transfers and lease agreements.
- E. If an ApHC transfer report is not available, an original bill of sale will be accepted, providing the necessary information is supplied thereon.
- F. If the registered owner of the horse is a minor and can write or print, his/her signature is required on the transfer report as seller. If the minor is too young and cannot write or print, we will accept the parent's signature, providing the age of the minor is given.
- G. No person shall make any alterations on a completed transfer report, or in any manner deface, change, or amend the provisions of it. If altered, a new transfer report will be required at the ApHC's discretion.
- H. In cases of divorce when a properly executed transfer report cannot be obtained, a certified copy of the divorce decree and property settlement, or other instruments satisfactory to the ApHC must be filed with the ApHC. The settlement must list all horses by registered name and number, as well as the name of the person appointed by the court to receive possession of the horses. The divorce decree and property settlement may serve as a transfer of ownership application, and the transfer will be completed to the person awarded the horses, or as an authorization for the receiver to sign any and all papers regarding the horses.
- I. If a horse is sold at a sheriff's sale, a certified copy of the sheriff's bill of sale or other instruments satisfactory to the ApHC must be filed with the ApHC. This certified copy or acceptable instrument will serve as the transfer of ownership application and the horse will then be transferred to the new owner.
- J. Upon completion of a transfer in the ApHC office, the Certificate of Registration shall be returned to the new owner. In the case of dual ownership the certificate will be sent to the address listed on the transfer report or to the first listed owner, unless a statement signed by the new owner is submitted along with the transfer report, instructing the ApHC to return the Certificate of Registration to someone other than the new owner.
- K. If the ApHC cannot complete the transfer, the Certificate of Registration will be retained in the ApHC office and an office charge will be assessed.
- L. If a dispute arises between seller and buyer, or lessor and lessee, it is suggested that you do not contact the ApHC office. The ApHC cannot act as judge or jury to decide who is right or wrong. The ApHC suggests that you contact an attorney and settle it in court. The ApHC will abide by the final decision of the court and will require a certified copy of the final court judgment or other instruments satisfactory to the ApHC to complete the transfer.
- M. To correct a date of sale on a transfer recorded with the ApHC, the ApHC must be provided with signed statements from both buyer and seller on the transfer report to be corrected, giving proper date of sale, the horse's original Certificate of Registration and the transfer correction fee. (See Fee Schedule.)
- N. For procedure regarding transfers of horses racing and claimed, see transfer of horses racing and claimed.

266. REGISTRATION APPEAL PROCEDURES

- A. The owner of a horse shall have the right to request that the ApHC Appeal Committee review (a) a rejection of the registration application relating to the horse, (b) the initial registration classification of the horse, or (c) the denial of a requested change in the registration classification of the horse.
 - 1. All such reviews shall be conducted at the next regular meeting of the Appeal Committee following receipt of a properly completed Appeal Notice Form. Forms available upon request through the Appaloosa Horse Club.
 - 2. An appeal fee shall be required for such review, which shall be refunded if the owner's appeal is upheld. (See Fee Schedule.)
- B. The owner shall submit at least four current colored photographs of the horse, including both sides, a direct face, and a rear view, and such other information as requested by the Registrar.
 - 1. If requested by the Registrar, the owner shall transport the horse to the location of the hearing for the purpose of inspection and/or examination by the Appeal Committee.
 - 2. The owner may submit a written statement to the Appeal Committee prior to the meeting and shall have the right, in person or by counsel, to appear and present evidence at the meeting and to hear and refute evidence offered against the subject horse.

267. APPEAL COMMITTEE

- A. The Appeal Committee of the ApHC Board of Directors shall consist of three members of the Board of Directors appointed by the President. The senior member of the Appeal Committee shall act as chairman.

268. REGISTRATION APPEAL COMMITTEE DECISION

- A. A written Notice of Appeal Committee Decision shall be mailed to the owner not later than 15 days after the meeting.
 - 1. The determination of the Appeal Committee shall be final and binding on all parties.
 - 2. Upon request, the owner shall, within 20 days of notice, return the Certificate of Registration, if any, of the subject horse to the Registrar for revocation, correction, or other appropriate action.

269. PROTEST PROCEDURES

- A. Any owner of a registered Appaloosa, or any current member of the ApHC, or any ApHC inspector, or tattooer, may protest the registration classification or status of any horse registered with the ApHC by filing an official protest form together with the protest fee. (See Fee Schedule.) The protest fee shall be refunded only if it is ultimately determined that the subject horse has been improperly registered.
- B. Each Director may request an inspection and/or examination of any horse which appears to be improperly registered. No protest fee shall be required in connection with any protest by a Director or ApHC Inspector.
- C. All protests shall be filed with the Registrar on an official protest form and shall be signed and dated by the person making the protest. Official protest forms may be obtained from the ApHC.
- D. All protests shall be reviewed by the Registrar under the direction of the Chief Executive Officer.
 - 1. The owner of the subject horse shall be mailed a written Notice of Protest with a copy of the protest form filed by the person making the protest within 30 days after receipt by the ApHC of a properly completed protest form.
 - 2. The Notice of Protest shall state the reason for the protest and shall set a date for inspection and/or examination, in accordance with ApHC Inspection Procedures, of the horse no later than 90 days nor earlier than 60 days after the date the Notice of Protest is given.

3. An alternative date may be selected if agreed upon in writing by the Chief Executive Officer and the owner.
- E. The owner shall promptly inform the Chief Executive Officer in writing of the location of the horse and, upon request, shall at the owners expense, transport the horse to a more convenient location to permit the inspection and/or examination. If the horse is not presented for the inspection and/or examination at the set date, the registration of the horse shall automatically be suspended and the horse shall be ineligible for any ApHC-approved events.
- F. The owner shall submit at least 4 current colored photographs of the horse, including both sides, a direct face and a rear view, and such other information as requested by the Registrar.
 1. Within 60 days following receipt of such information and inspection and/or examination of the horse, if any, the Registrar shall conduct a hearing to review the protest.
 2. Any interested parties may submit a written statement to the Registrar prior to the hearing and shall have the right, in person or by counsel, to appear and present evidence at the meeting and to hear and refute evidence presented.
- G. The Registrar shall mail to the owner of the horse and protestant a written Notice of Decision concerning the protest within 30 days following the hearing before the Registrar.
- H. The registration status of the subject horse shall automatically be suspended if the owner fails to appeal within such 20-day period and, upon written request, the owner shall, within 20 days, return the Certificate of Registration of the subject horse to the Registrar for revocation, correction or other appropriate action.
- I. No person who files a protest or who otherwise participates, directly or indirectly, in filing a protest shall serve in any capacity in the determination of the validity or invalidity of the protest including any appeal thereof.
- J. All persons involved in any ApHC registration protest agree that they will not commence any action related to any such protest, whether in law or equity, against the ApHC in any courts other than those Federal and State courts located in Latah County, Idaho.

270. PROTEST APPEAL PROCEDURES OF REGISTRAR'S DECISION

- A. In the event that the Registrar has determined that the registration of a horse shall be revoked or corrected as a result of a protest, the owner of the subject horse shall have the right to appeal the decision of the Registrar to the Appeal Committee of the ApHC Board of Directors.
 1. No such appeal shall be heard unless an Appeal Notice Form signed by the owner or his authorized agent together with the appeal fee is received by the ApHC within 20 days from the date the Notice of Decision was given to the owner.
 2. If the owner's appeal is upheld the fee will be refunded.
- B. The Appeal Committee shall conduct a formal hearing as soon as practicable after the receipt of an Appeal Notice Form.
 1. Written notice of the date, time, and location of the hearing shall be mailed to the owner not less than 15 days prior to the hearing.
 2. In selecting the location for the hearing, consideration shall be given to the residence of the owner and the location of the subject horse.
 3. If requested by the Registrar, the owner shall at the owners expense, transport the horse to the location of the hearing for purposes of an inspection and/or examination by the Appeal Committee.
- C. If the horse is protested because of its Regular registration status, the owner may elect within 15 days after filing the appeal and paying the appeal fee, to apply for an Appaloosa Horse Club Performance Permit, and comply with all such application requirements within sixty (60) days of filing said appeal. The owner may then waive the hearing provided for in this rule, pending completion of the Performance Permit application process. If the Performance Permit is issued by the ApHC to the protested horse, the protest will be dismissed and the appeal fee refunded.

- D. During the pendency of the appeal and/or Performance Permit any points or awards earned or subsequently earned by the protested horse, will be escrowed pending completion of the appeal and/or completion of the Performance Permit application process.
- E. The owner may submit a written statement to the Appeal Committee prior to the hearing and shall have the right, in person or by counsel, to appear and present evidence at the hearing and to hear and refute evidence offered against the subject horse.
- F. A written Notice of Appeal Committee Decision shall be mailed to the owner not later than 15 days after the hearing.
 1. The determination of the Appeal Committee shall be final and binding on all parties.
 2. Upon request, the owner shall, within 20 days of said request, return the Certificate of Registration of the subject horse to the Registrar for revocation, correction or other appropriate action.

271. INSPECTION PROCEDURES

- A. An applicant, upon completion of an instructional course may be eligible to serve as an ApHC Inspector and/or Tattooer.
- B. The Registrar shall designate an inspector to photograph and conduct a visual inspection at the horse owner's expense, of every horse which has been protested or for which an inspection has otherwise been required. If the protest is not upheld, then all inspector expenses shall be reimbursed by the protester.
 1. After identifying the subject horse, the inspector shall photograph the horse as requested by Registrar and shall note on the back of the photographs the name and registration number of the horse, if any, and the place and date the photographs were taken.
 2. The inspector shall also complete a written report detailing the results of the inspection, including the place, time and date of the inspection and the names and addresses of any witnesses present.
 3. The inspector shall forward the inspection report and photographs to the Registrar as soon as practicable.
 4. The inspector is not authorized to make a decision as to the proper registration classification of the horse being inspected. All such decisions will be made by the Registrar after reviewing the inspection report, photographs and veterinarian reports, if any.
- C. The Registrar may, in his/her sole discretion, require a physical examination of the subject horse by a veterinarian to determine the horse's age, sex status, height or other physical attributes and/or obtain blood, urine or hair samples and biopsies.
 1. The veterinarian shall submit a written report of any such examination to the Registrar as soon as practicable.
 2. The complete expense of the veterinary and laboratory fees shall be the sole responsibility of the owner of the horse.
- D. The Registrar shall review the inspection report, photographs, veterinarian's report, if any, and any other information on file or submitted by the owner, and shall give the owner a written Notice of Decision not later than 15 days after reaching said decision.
 1. If the decision of the Registrar is adverse to the owner, the Notice of Decision shall be accompanied by an Appeal Notice Form and a description of the appeal procedures available to the owner.
 2. If the Registrar determines that the reports and photographs are inconclusive, a second inspection and/or examination may be required by the Registrar at his/her sole discretion. The complete expense of a second inspection and/or examination shall be the sole responsibility of the owner of the horse.
- E. If the protest is not upheld, then all expenses shall be reimbursed by the protester.

272. IDENTIFICATION FOR NATIONAL EVENTS

- A. Every horse which is to be entered in the National Appaloosa Horse Show, World Championship Appaloosa Youth Horse Show, the World Championship Appaloosa Horse Show shall be identified by an official ApHC Inspector prior to participating in the show.
- B. Every horse that is entered in the National Sale and/or World Championship Sale shall be identified by an official ApHC Inspector prior to participation in any such sale.
- C. All approved shows or sales requesting the services of an inspector and paying the appropriate fee shall be required to follow the procedures set forth in this section.
- D. An official ApHC Inspector shall be available for such purposes at the time of such shows or sales.
 1. The inspector may, in the inspector's sole discretion, refuse to allow a horse to participate in such show or sale if the registration of the horse appears invalid or otherwise improperly issued. The inspector may, for example, refuse to permit the horse to participate in such show or sale if the horse does not display Appaloosa characteristics so as to be eligible for Regular registration, unless the ApHC has issued the horse a CPO Certificate of Registration or, a Certificate of Registration including a Performance Permit, and/or the horse is otherwise eligible for registration.
 2. An official ApHC Inspector's refusal to permit a horse to participate in a show or sale at the time of the national event, shall constitute an adverse determination that the registration of the horse shall be reclassified or canceled.
 3. The inspector may make a determination that the Certificate of Registration merely needs a correction and so stamp the Certificate of Registration. This correction procedure shall not constitute an adverse determination.
 4. If an ApHC Inspector refuses to permit a horse to participate in the show or sale thus constituting an adverse determination, the inspector shall prepare and forward to the Registrar an inspection report and photographs as specified in INSPECTION PROCEDURES.
- E. Horses entered in either the ApHC National or World shows and passed through the inspection station will be exempt from future inspections at either of these shows. At the time passed, the inspector will annotate the Certificate of Registration with the date, and legibly sign his/her name indicating that this horse has been visually inspected and conforms to the requirements for registration of the Appaloosa Horse Club.

273. APPEAL OF NATIONAL EVENT IDENTIFICATION

- A. If an official ApHC inspector refuses to permit a horse to participate in a show or sale at the time of the national event, the owner shall have the right to appeal such refusal to the Appeal Committee of the ApHC Board of Directors.
 1. No such appeal shall be heard unless a written petition signed by the owner or his authorized agent together with the appeal fee shall be received by the ApHC within 20 days after the date of the inspector's refusal.
 2. The petition shall set forth (a) the name of the inspector, (b) the date and place of the refusal, (c) the reasons for the appeal and (d) the address to which notices from the ApHC may be mailed.
 3. If the owner's appeal and fee are timely filed, the horse may show and/or enter the sale pending the outcome of the Appeal Committee Hearing but any points or awards earned at that show or any subsequent shows will be escrowed pending completion of the appeal process.
 4. The registration status of the subject horse shall automatically be suspended if the owner fails to appeal within such 20 day period and, upon written request, the owner shall, within 20 days, return the Certificate of Registration of the subject horse to the Registrar for revocation, correction or other appropriate action.

- B. The Appeal Committee of the Board of Directors of the ApHC shall conduct a formal hearing in accordance with the procedures set forth in the Protest Appeal Procedures of Registrar's Decision as soon as practicable after the receipt of any such petition and its decision shall be final and binding on all parties.

274. HORSE'S AGE

- A. The age of a horse shall be computed on the basis of a calendar year starting on January 1 of the year foaled. A horse is not eligible to participate in events approved by the ApHC if its age as determined by examination of its teeth does not correspond to the age shown on its Certificate of Registration, such determination by dental examination to be made in accordance with the current Official Guide for Determining the Age of the Horse as adopted by the American Association of Equine Practitioners.
- B. Every exhibitor, owner, or trainer, upon request by a representative of the ApHC, show manager, or stewards at a race meet, shall permit such examination to be made by a representative of the ApHC and/or a licensed veterinarian. Refusal to comply with such request shall constitute grounds for immediate disqualification of the animal from the ApHC event in progress or any other ApHC-approved event, and shall constitute grounds for suspension of ApHC membership.
- C. Should such examination show the animal's age does not correspond to the foaling date shown on its Certificate of Registration, such examination shall constitute prima facie evidence that the animal's age as shown on its Certificate of Registration is erroneous. The animal automatically shall be suspended from participating in the ApHC event in progress and any future ApHC-approved events pending a hearing before the Legal and Disciplinary Committee.
- D. The exhibitor, owner, or trainer, upon request by a representative of the ApHC, show manager or stewards at a race meet, shall deliver the animal's Certificate of Registration to the requesting party. The representative of the ApHC, show manager or stewards at a race meet receiving the Certificate of Registration immediately shall forward the Certificate of Registration and affidavits from the person or persons making such examination and findings, to the Chief Executive Officer of the ApHC.
- E. At a time and place designated by the Legal and Disciplinary Committee at the next regularly scheduled meeting, a hearing will be held, at which time the animal's recorded owner and/or breeder shall provide evidence to substantiate the foaling date shown on the Certificate of Registration. In the absence of substantial evidence to the contrary, the Legal and Disciplinary Committee may cancel the animal's registration and take appropriate action against the person or persons involved.
- F. Instead of a certificate cancellation, if the pedigree is substantiated, but the age discrepancy remains unresolved, the Legal and Disciplinary Committee may direct that an appropriate notation be made on the Certificate of Registration to allow the horse to be used for breeding purposes, but prohibiting its participation in approved events.

Rules 275-399 are not assigned.

400. AFFILIATED ORGANIZATIONS

- A. Regional Clubs
 1. A complete regional club guide with model by-laws is available from the ApHC, and may be obtained by writing to the Regional Club Coordinator at the Moscow office.
 2. Regional clubs are authorized and supported by the ApHC for the purpose of advancing and promoting the Appaloosa horse, encouraging ideas of good horsemanship and good sportsmanship, and providing activities for ApHC

- members on a regional basis. Regional clubs must be chartered and shall operate under the supervision of the ApHC through the ApHC Board of Directors and its regional club committee.
- B. To obtain a regional club charter, a group must:
1. Send to the ApHC the following information concerning the club:
 - a. Articles of Incorporation and bylaws. Articles must consist of a “purpose” which states, “to cooperate with and aid in every way possible the programs and functions of the ApHC” and “to uphold the policies of the ApHC”.
 - b. Submit a list of directors, officers and committee chairpersons.
 - c. Submit a membership list which must consist of at least 25 ApHC members in good standing and include each members name, address and ApHC membership number.
 2. Obtain approval of the ApHC Board of Directors if a regional club is currently chartered by the ApHC in the state which the regional club charter is sought.
- C. In a state where a regional club currently exists, a new regional club may not be chartered without consent from the ApHC Board of Directors. Upon receiving any application for a new regional club in a state where a regional club currently exists, the ApHC will notify all existing regional clubs in that state and solicit input regarding such application. The ApHC Board of Directors will decide, based upon the best interest of the ApHC, whether any new regional clubs will be chartered.
- D. To retain a club charter, a regional club must have at least 15 ApHC members in good standing. Failure to do so for two consecutive calendar years will subject any such club to loss of charter after notice and hearing. Each regional club must submit annually:
1. An annual report, signed by the President or Secretary, to be completed at an annual meeting of its members due February 15; notice of new officers and directors must be sent to the ApHC within thirty days of the election but not later than February 15. All ApHC regional club presidents and vice presidents must be ApHC members in good standing. All other ApHC regional club officers should be ApHC members in good standing.
 2. Bylaws with the first report and any subsequent reports if any changes have been made during that year;
 3. A complete membership/address list of paid members due July 15. Please include ApHC membership numbers where applicable;
 4. Corrected/updated membership lists due September 10 in conjunction with nominations for regional qualifiers for the World Show.
 5. Submit with Annual Report a meeting summary or minutes of at least one (1) regional club membership meeting conducted during the prior calendar year.
 6. Submit regional club’s income statement from prior fiscal year.
 7. Submit list of regional club activities during prior calendar year.
- E. Once a regional club is chartered, it may not engage in any business or activities in the name of, or on behalf of, directly or indirectly, the ApHC, without written consent of the Chief Executive Officer of the ApHC. In the event any activity is undertaken with the consent of the ApHC, it shall be named as co-insured on any policy of insurance covering any of the risks attending such event.
- F. The articles of incorporation and constitution, bylaws and rules of each regional club must conform to the state or country laws of incorporation or organization and be consistent with the ApHC bylaws and rules. Regional clubs must amend their bylaws and rules from time to time to conform with amendments to ApHC bylaws and rules. Regional clubs shall uphold the bylaws, rules and policies of the ApHC and promote and encourage ideas of good horsemanship and good sportsmanship. Regional clubs not adhering to the bylaws, rules or policies of the ApHC or whose activities bring disrepute to the ApHC or are detrimental to the best interests of the ApHC, shall be subject to sanctions after notice and hearing.

1. It shall be a violation of ApHC rules for ApHC regional club members, officers and/or directors to engage in conduct detrimental to the legitimate business interests of the ApHC and a regional club, including the following conduct:
 - a. A former regional club member’s, officer’s or director’s failure to return a regional club’s books and/or records to the proper officers of the regional club;
 - b. Unauthorized use of regional club and/or ApHC property, including intellectual property rights such as trade name and logo, or
 - c. Acting or purporting to act on behalf of a regional club without authority.
- G. Failure to comply with Rule 400(D) within 30 days of the listed deadlines shall result in a \$50 fine. Failure to comply with Rule 400(D) by September 10 may result in loss of charter after notice and hearing. Failure to comply with any ApHC rule may, upon complaint in accordance with ApHC rules, result in probation, temporary suspension of regional club’s rights and privileges, or revocation of charter, after notice to the regional club’s secretary or officer, sent to their last known address, and hearing before the ApHC Executive Committee. The regional club will be notified in writing of the decision of the ApHC Executive Committee. A regional club that has not complied with Rule 400.D. for two (2) or more consecutive years may have their charter placed in an inactive, escrowed status, and any such regional club cannot retain and operate under its club charter without complying with Rule 400.B.
- H. International Partners:
Effective January 1, 2000, to become an International Partner of the ApHC or to retain status as an International Partner, a group must:
1. Send to the ApHC the following information concerning the group:
 - a. Articles of Incorporation and By-laws or similar documentation recognized by the country of origin. Articles must consist of a “purpose” which states, “to cooperate with and aid in every way possible the programs and functions of the ApHC” and “to uphold the policies of the ApHC,
 - b. A list of directors, officers and committee chairpersons, and
 - c. A membership list that includes each member’s name, address and ApHC membership number where applicable.
 2. Obtain written approval from the ApHC Board of Directors.
- I. To retain International Partnership, each Partner must submit annually:
1. Due February 15 of each year -
 - a. A list of all directors, officers and committee chairpersons, signed by the president or secretary and
 - b. A complete list of all members including names, addresses and ApHC membership numbers where applicable.
 2. Due September 10 of each year -
 - a. A complete list of all members including names, addresses and ApHC membership numbers where applicable.
- J. An International Partner may not engage in any business or activities in the name of, or on behalf of, directly or indirectly, the ApHC, without written consent of the Chief Executive Officer of the ApHC. In the event any activity is undertaken with written consent of the ApHC, the ApHC shall be named as co-insured on a policy of insurance covering all risks attending such event in amounts acceptable to the ApHC. The ApHC shall be provided with a certificate of such insurance prior to the commencement of the approved activity.
- K. International Partner shall uphold the policies of the ApHC.
- L. Failure to comply with Rule 400(I) by the listed deadlines may result in loss of affiliation after notice and hearing. In connection with action on all other matters, the ApHC can disaffiliate a group for good cause. After notice of hearing has been given in writing to the affiliate’s secretary and/or president, the ApHC Board of Directors will determine if the group will remain as an International Partner. The International Partner will be notified in writing of this determination.

M. Official International Partners of the Appaloosa Horse Club shall be published by the ApHC in *Appaloosa Journal* and/or the ApHC web site and/or by electronic communication to ApHC members.

N. International Agreements

1. The ApHC Board of Directors is authorized to enter into agreements, at its discretion, with international entities and/or organizations, for the purposes of promoting, enhancing and improving the Appaloosa breed. In entering into any such agreements the ApHC Board of Directors is expressly authorized, at its discretion, to modify and/or waive the strict application of the ApHC fee schedule and/or membership rules and to create registration incentives as determined by the ApHC Board of Directors to be in the best interests of the ApHC.

401. GUIDELINES FOR A STATE OR AREA ASSOCIATION

A. A state association must be formed as a nonprofit corporation with Articles of Incorporation and bylaws prepared according to the controlling laws of the state of incorporation.

B. State associations may meet the above requirements by:

1. Affiliation (Club of Clubs): Several regionals in a state may join to affiliate and form a state association with new Articles of Incorporation and bylaws.
2. Merger: Dissolve all but one incorporated regional club and use this nonprofit corporation for the state association. Prior existing regionals being merged should file dissolution documents with appropriate state agencies and the ApHC. All regional clubs who wish to merge may do so on a one-year trial basis, with their respective charters held in escrow to be returned if requested. All affected regionals are required to give written support and approval to such a merger.
3. State racing associations in which membership is separate from membership in a regional club.
4. State associations formed prior to January 1, 1990 with active programs and membership as of December 31, 1990 and whose membership is separate from regional clubs.
5. Contiguous states each with fewer than 300 ApHC members and three or fewer regional clubs may qualify as an area association under A or B above.

C. State or area association status will not be granted until the following minimum information together with all other requested data is supplied to the ApHC and reviewed by the Regional Club Committee and thereafter affirmed and approved by the Board of Directors.

1. Articles of Incorporation and bylaws.
2. List of Directors and Officers.
3. Association's geographic boundaries.
4. Membership list with names and ApHC membership numbers.
5. Name, mailing address and phone number of secretary or agent to contact regarding information for the association.
6. Any other existing requirements for a regional club.
7. A majority of ApHC members of regional clubs affected by the formation of a state or area association must give approval to the formation of such association.

D. If the association is formed by merger, it will be entitled to a minimum number of invitations to the World Show based on the cumulative number of invitations issued the prior year to the merged clubs forming the association provided the one National point qualification is met and that eligible horses have not qualified through the National point system.

E. This provision is not available to an association formed by affiliation of regional clubs that maintain their charters and who independently qualify horses for the World Show.

F. State associations described in 401(D) may qualify horses for the World Show under the same rules governing regional clubs. Invitations will not be made available to horses which qualify through the National point system or a regional club.

G. The use of prior show names and protected dates from regional clubs merged to form an association will be given a right of first refusal according to the existing show date allocation rules or such subsequent rules as may be hereafter adopted.

H. Except as modified herein, state or area associations will have the same rights and privileges accorded to regional clubs. They must also assume the same responsibilities to the breed and the ApHC. State or area associations are subject to the same disciplinary actions as regional clubs.

RACING PROGRAM

402. GOVERNANCE AND RECORD KEEPING

A. The Appaloosa racing program exists to promote racing of Appaloosa horses. Appaloosa racing is to be governed by applicable state law and by a duly authorized State Racing Commission or authority in each state where Appaloosas compete. The ApHC does not intend for its rules and regulations to conflict with any state laws in regard to racing and, in the event of any conflict, the state law shall control.

B. The ApHC maintains race records on every eligible horse, as defined by ApHC rules, that races in a state with a racing commission or turf governing body and at a track recognized under racing regulations of the American Quarter Horse Association (recognized track).

C. An owner and/or trainer, upon entering an eligible horse at a recognized track, does thereby agree to abide by and be governed by ApHC rules and regulations.

403. IDENTIFICATION REQUIREMENTS FOR RACING ELIGIBILITY

A. Every horse properly registered with the ApHC carrying Regular (#), CPO (CN) or Non-characteristic (N) registration papers which is to be entered in an ApHC-recognized race must be tattoo-branded on the inside of the upper lip with an official identification number corresponding to the horse's registration number, and must be parentage verified through the ApHC by means of DNA genetic testing. (SEE DNA TESTING). ApHC records must contain proof of parentage verification prior to the race date, in order for the ApHC to maintain records on that horse. Horses without a tattoo, or whose Certificates of Registration do not state, "Parentage Verified" shall be ineligible to have records maintained by the ApHC.

B. Any such horse properly registered with the ApHC carrying Regular (#) registration papers, which cannot be parentage verified due to the death or foreign export of the sire and/or dam, may apply to the ApHC Appeals Committee by written application for consideration of a hardship exemption to obtain required parentage verification.

C. The tattooing of properly registered Appaloosa horses must be performed by an official track tattooer (approved tattooer) or ApHC Inspector, upon payment at the time of tattooing. The approved tattooer shall refuse to tattoo a horse if the registration of the horse appears invalid or if the horse does not, for any reason, match its Certificate of Registration. The approved tattooer and/or track identifier, shall refuse to permit any horse to participate in a race if the horse's Certificate of Registration does not state "Parentage Verified," and/or if the horse has an improper Certificate of Registration, and/or if the horse is otherwise ineligible for ApHC registration.

D. An approved tattooer's refusal to tattoo a horse and/or an approved tattooer's and/or track identifier's refusal to permit a horse to participate in a race because

the horse has an improper Certificate of Registration or is otherwise ineligible for registration shall constitute a determination that the registration of the horse should be reclassified or canceled. However, the approved tattooer and/or track identifier may make a determination that the Certificate of Registration merely needs correction and so stamp the Certificate of Registration. This correction procedure shall not constitute a determination. If the approved tattooer refuses to tattoo a horse, the approved tattooer and/or track identifier shall prepare and forward to the Registrar an inspection report and photographs as specified in INSPECTION PROCEDURES.

- E. If an approved tattooer refuses to tattoo a horse at the time of a race, the owner shall have the right to appeal such refusal to the Appeal Committee of the ApHC Board of Directors. No such appeal shall be heard unless a written petition signed by the owner together with the appeal fee is received by the ApHC within 20 days from the date of the tattooer's refusal to tattoo the horse. The petition shall set forth (a) the name of the tattooer, (b) the date and place of the refusal, (c) the reasons for the appeal, and (d) the address to which notices from the ApHC may be mailed. If the owner's appeal is upheld the fee will be refunded. If the written appeal and fee are timely filed, the horse may race pending the outcome of the Appeal Committee hearing, but points, awards, or monies earned at that or any subsequent race prior to finalization of the appeal process will be escrowed. The registration status of the subject horse shall automatically be suspended if the owner fails to appeal within such 20-day period and, upon written request, the owner shall return the Certificate of Registration of the subject horse to the Chief Executive Officer for revocation, correction or other appropriate action.
- F. The Appeal Committee of the ApHC Board of Directors shall conduct a formal hearing in accordance with the procedures set forth in PROTEST APPEAL PROCEDURES OF REGISTRAR'S DECISION as soon as practicable after receipt of any such petition and its decision shall be final and binding on all parties.
- G. Change from Stallion to Gelding: When a stallion is gelded, the Certificate of Registration must be corrected by an approved tattooer and/or track identifier and the ApHC must be notified, by written verification, of the date the horse was gelded.

404. LEASES

- A. For information on correct procedures for a lease of a horse for racing purposes, please see Leases.

405. TRANSFERRED AND/OR CLAIMED HORSES

- A. When a horse is properly claimed at a recognized track, the racing secretary at said track shall collect a transfer fee and membership fee, if necessary, from the claimant which shall be forwarded to the attention of the ApHC's Racing Coordinator together with the Certificate of Registration, a written report of the race showing the date of the race and the name and address of the person claiming the horse. Upon receipt of such fee(s), Certificate of Registration, and report, the ApHC will complete the transfer without the report being signed by the record owner. If the notice of claim and supporting documents are received by the ApHC within 14 days of the claim, the transfer will receive a free special handling rush service, as long as "RUSH" is noted on the outside of the envelope.
- B. When a horse is sold at a recognized track, the racing secretary at said track shall collect a transfer fee and membership fee, if necessary, from the buyer which shall be forwarded to the attention of the ApHC's Racing Coordinator, together with the Certificate of Registration, and a properly completed transfer report. Upon receipt of such fee(s), Certificate of Registration, and properly completed transfer report, the ApHC will complete the transfer. If said requirements are received by the ApHC within 14 days of the date of sale, the transfer will receive special handling rush service, as long as "RUSH" is noted on the outside of the envelope.

- C. Upon completion of a transfer in the ApHC office, the Certificate of Registration shall be returned to the new owner, unless a statement signed by the new owner or the racing secretary of the track at which the change in ownership took place, is submitted along with the transfer report, instructing the ApHC to return the Certificate of Registration to someone other than the new owner.

406. RACE RESULTS

- A. Any organization, club, or individual desiring ApHC recognition of the results of its or their Appaloosa races in states or countries without a racing commission or turf governing body must obtain permission from the ApHC to have those results recognized. In cases where races are run under state laws, the rules and regulations of the duly authorized racing commission shall take precedence over ApHC rules and regulations.
- B. Race results shall be filed with the ApHC following each day's racing within 24 hours of the race either by express delivery or fax transmission. A hard copy of the chart and complete program for the day may be mailed the next business day following the running of the race. These results must be in the ApHC office within ten (10) days of the race. If race results are not filed within the allotted time, the ApHC shall have the right to waive the filing deadline.
- C. Race results include photo-finish film strips of races timed in at least hundredths of a second when available, an official race chart, and an official program for each day's racing which includes conditions of the race, distance, names of the horses in each race, their respective post positions, color, sex, age, breeding, owner, trainer, jockey and weight carried; and names of the officials.
- D. Any ruling by any State Racing Commission or other racing authority shall be filed with the ApHC.

407. RACE DESCRIPTIONS

- A. Stakes Races - A stakes race is a race in which stakes of \$50 or more are to be posted by the owners of the horses engaged and is still a stakes when money or other prize is added. Nominations must close more than seventy-two hours before the first race of the day on which such stakes are to be run. A stakes may not be restricted or exclude entries in any way other than age or sex. No race with a purse of less than \$2,500 will be considered as a stakes. However, an invitational stakes race or an invitational handicap race for which owners do not contribute to the purse, but which is advertised in the regular stakes program, shall also be considered a stakes race, provided it carries a minimum purse of \$2,500.
- B. Restricted Stakes Race - The following types of races will be classified restricted stakes:
 - 1. Races restricted to state of breeding, foaling and/or ownership.
 - 2. Races restricted to those horses sold in a specific sale or sales.
 - 3. Races restricted to the progeny of a restricted stallion or group of stallions so listed by a race.
- C. Annually, the ApHC's Executive Race Committee will consider for grading, every stakes and restricted stakes race that has been conducted or may be scheduled to be conducted in the following year.
 - 1. Stakes races may be graded as Grade 1, 2, or 3, with Grade 1 being the highest grade. Restricted stakes may be graded as Restricted (R) 1, 2 or 3 with Restricted (R) 1 being the highest grade.
 - 2. Primary consideration for grading will be the quality of horses attracted to the race and such factors as longevity of the race, competition, conditions, purse and prestige.

408. RACE AWARDS

- A. Annually, a fee of \$10 will be assessed for each horse, payable before the first official race start. Late payment of this fee may be made within 30 days subsequent to a horse's first start by paying a late payment penalty of \$100. Non-payment of the assessment will not reflect on a horse's past performance as

records will be kept on all horses; however, if a horse qualifies for any ApHC award(s) he will be ineligible to receive it if the \$10 fee or subsequent late payment penalty has not been paid. Races run prior to the payment of the Annual starter's fee will not be considered in year-end calculations for any award. All racing year-end awards will be awarded to the owner or lessee on record as of December 31 of the qualifying year."

B. Registers of Merit

1. Racing Registers of Merit (ROM) can be achieved by obtaining a speed index of 80 or higher or achieving a speed rating of 98 or higher. A speed index or a speed rating will only be awarded for approved times at recognized official distances.

a. SPEED INDEX. A speed index will only be awarded for approved electric times at recognized official distances timed in hundredths of a second. Horses starting at a recognized track may receive a speed index based on the American Quarter Horse Speed Index Chart for that year and track. Speed indexes are based on an average of the three fastest winning electric times run each year for the immediate past three years for each distance at each track. The average of the nine times (to the nearest 1/1000 (.001) of a second) will represent a speed index of 100. No Speed Index will be issued due to a hand-time caused by the malfunction of the electric timer.

1. A speed index point varies according to the distance of the race as follows:

- .087 equals one speed index point at 870 yards.
- .077 equals one speed index point at 770 yards.
- .066 equals one speed index point at 660 yards.
- .055 equals one speed index point at 550 yards.
- .044 equals one speed index point at 440 yards.
- .04 equals one speed index point at 400 yards.
- .035 equals one speed index point at 350 yards.
- .033 equals one speed index point at 330 yards.
- .03 equals one speed index point at 300 yards.
- .025 equals one speed index point at 250 yards.
- .022 equals one speed index point at 220 yards.

2. The following times will be used to compile speed indexes at tracks where the average times are slower than the Minimum Standard Time.

OFFICIAL DISTANCE (for 100 Speed Index)	MINIMUM STANDARD TIME
220 yards - straightaway	11.95
250 yards - straightaway	13.35
300 yards - straightaway	15.55
330 yards - straightaway	16.95
350 yards - straightaway	17.85
400 yards - straightaway	20.15
440 yards - straightaway	22.05
550 yards - straightaway	27.70
660 yards - straightaway	33.50
660 yards - around one turn	34.60
770 yards - around one turn	40.36
870 yards - around one turn	45.60

3. Should a dead heat occur all horses involved will receive the same speed index based on the place for which they dead-heated. All other horses will receive the speed index based on their actual finish. A disqualified horse will receive the speed index of its final placement.

b. SPEED RATING. A speed rating will only be awarded for approved times at recognized official distances timed in fifths of a second. Horses starting for the first time at tracks eligible for recognition by the ApHC or when a new distance is being run will receive a speed rating based on the average of the three fastest Appaloosa times at the track for that distance. The distance must be run three times before an Appaloosa track record will be established or a speed rating given for that distance at that track.

1. The speed rating is a comparison of the horse's final time with the Appaloosa track record established prior to the opening of the race meet. To determine the speed rating of the winning horse the track record is given a rating of 100 points; one point is deducted for each fifth of a second by which the winning horse fails to equal the track record; and one point is added for each fifth of a second by which the winning horse beats the track record. One-half, three-quarters and one length are equal to one point. One-fourth, nose, head and neck are equal to zero points. To determine the speed rating of the rest of the field one point is subtracted for each length a horse is behind the preceding horse. (If the winning horse had a speed rating of 100 and the second place horse was two lengths behind it, its speed rating would be 98. If the third place horse was two lengths behind the second place horse the speed rating would be 96. If the fourth place horse was a head behind the third place horse the speed rating would be 96. If the fifth place horse was 1/2 length behind the fourth place horse its speed rating would be 95, etc.) One-half (1/2) and three-quarter (3/4) lengths are equal to one full length. One-fourth (1/4), nose, head and neck equal zero (0) lengths. One length is equal to approximately one-fifth of a second (or one point) and fractions of one-half length or more are figured as one full length (or one full point). Fractions less than one-half length are figured as no lengths (or no points). If any horse is distanced it gets no speed rating.

2. Only races recognized by the ApHC will be considered for Regional High Point Champions, ROM's, Medallions, and ERC Champions.

C. Champion Year-End Horses

Annually, by written ballot of the ApHC's Executive Committee (ten (10) votes) and the Oklahoma Appaloosa Racing Association (OAR) (four (4) votes) and the Western Regional Appaloosa Racing Council (WRARC) (four (4) votes), champion running horses in each of thirteen categories may be named. The two regional clubs must each designate four (4) individual voting members. Designated members must reside in different states, must be ApHC members in good standing, and may not be current voting ERC members. A horse must earn a minimum of \$10,000 in purse monies or have at least one graded stakes win or graded stakes placing in a race where results are recognized by the ApHC, to be eligible for the ERC year-end awards.

1. The following awards may be given in each of three age divisions: Champion two-year-old sprint colt, champion two-year-old distance colt, champion two-year-old sprint filly, champion two-year-old distance filly, champion two-year-old sprint gelding, champion two-year-old distance gelding, champion three-year-old colt, champion three-year-old filly, champion three-year-old gelding, champion four and older stallion, champion four and older mare, champion four and older gelding, champion claiming horse. Only claiming races will be considered for champion claiming horses.

2. A Supreme Champion Two-Year-Old and Horse of the Year will be named from those thirteen categories.

D. Medallions

Racing medallions will be issued to the top three eligible horses in each age and sex category. Medallion points will be figured using a formula of the number of wins times the amount of money earned, as officially recorded by the ApHC, for the qualifying year. Place and show in a stakes race will be counted as a win. Non-characteristic (N) registered Appaloosas must purchase either a Race Medallion Permit or a Performance Permit prior to becoming eligible to earn medallion points. Racing medallions are awarded to the first listed owner or lessee on record as of December 31 of the qualifying year.

E. Regional High-Point Champions

1. Annually, forty-five high-point champions may be named, based on a point system which places emphasis on horses demonstrating consistency and durability in their performance within a specific region. Points will be figured using a formula of the number of wins times the amount of money earned, as officially recorded by the ApHC, for the qualifying year. Place and show in a stakes race will be counted as a win.

The regions are:

East-Central: Kansas, Michigan, Kentucky and Florida

South-Central: Oklahoma, Texas

West-Southwest: New Mexico, Colorado, Wyoming, Utah and Nevada

Western-California

Northwest-Montana, Idaho, Oregon, and Washington

2. The following categories in each of the five regions may receive a certificate of recognition: regional champion two-year-old colt, regional champion two-year-old filly, regional champion two-year-old gelding, regional champion three-year-old colt, regional champion three-year-old filly, regional champion three-year-old gelding, regional champion four-and-older stallion, regional champion four-and-older mare, regional champion four-and-older gelding.

409. CUTTER AND CHARIOT RACING.

Only results of cutter and chariot racing contests conducted under the direct supervision of a State Racing Commission and/or the World's Champion Cutter and Chariot Racing Association (WCCRA) will be accepted for recognition by the ApHC.

A. ApHC'S STATEMENT OF DISCLAIMER OF RESPONSIBILITY FOR SAFETY AT CUTTER AND CHARIOT RACING CONTESTS:

1. ApHC will accept cutter and chariot racing contest results as official and use such results to calculate awards.
 2. ApHC does not assume or accept duty or responsibility for safety at these racing contests in regard to participants or any other third parties, or for the horses or other property thereof, which responsibility remains solely with track management and the WCCRA.
- B. Unless otherwise specified in this handbook, the racing rules of the WCCRA will be utilized for the governance of cutter and chariot racing recognized by the ApHC.
- C. A cutter and chariot racing contest shall consist of a series of races constituting one complete go-round for all horses entered, each of which races shall match two or more two-horse teams pulling a cutter and driver or a chariot and driver. For a contest to be recognized, twelve teams of registered horses (24 horses) must compete.
- D. All ApHC horses participating in cutter and chariot races must be properly identified as stated in IDENTIFICATION REQUIREMENTS FOR RACING ELIGIBILITY. In order to be eligible for any ApHC award, the horse must be properly registered and identified, the annual starter's fee must be paid prior to the cutter/chariot racing season and the owner must be a current year member of the ApHC.

E. Cutter and chariot racing is a timed event, with placings determined on the basis of time lapsed for each team in the contest. The winning team in each contest will be the team with the least lapsed time, between the time the starting gates open to dispatch the horses until the nose of the leading horse on such team crosses the finish line.

F. Any horse finishing first, and any horse randomly selected by the stewards in a cutter and chariot racing contest shall be properly tested for the presence of unauthorized drugs or foreign substances in accordance with RCI Drug Testing and Quality Assurance Program guidelines.

G. Officials of a cutter and chariot racing contest shall consist of a presiding steward and two associate stewards, a starter, a clerk of the scales and three timers. In the event an electric timer is used, there must still be two hand-timers. The time for any given team will be the time electronically recorded for that team, or the average of the hand timers in the event the electric timer is not used or fails to operate.

H. To be eligible for placing, the aggregate weight of the cutter or chariot, harnesses, bridles and driver for such team must not be less than 275 pounds.

I. A cutter and chariot race must be started from a closed starting gate and conducted on a straight course.

J. During the course of a cutter and chariot race, if a team moves out of the lane in which it starts in such a manner that it interferes with or impedes another team, the offending team shall be disqualified when, in the opinion of the stewards, the outcome of the contest was affected. Any such team disqualified shall be placed behind the team or teams it fouled, and shall be given the time of the team it was placed behind, plus .01 second, or the maximum accuracy of the timer not to exceed .001 second.

K. Registers of Merit and official speed indexes shall be awarded as listed under RACING AWARDS.

L. An appropriate award will be presented to the first recorded owner or lessee of each horse during the racing season of the top Appaloosa Cutter/Chariot horse or team as determined by the WCCRA and ApHC eligibility requirements as stated in the *Official Handbook* of the ApHC.

Rules 410–419 are not assigned.

420. APPALOOSA COMPETITIVE ALL-BREED ACTIVITIES PROGRAM (ACAAP)

ACAAP is a program designed to promote the Appaloosa horse in competition outside of ApHC approved or sponsored shows by recognizing and awarding Appaloosas for excelling in all-breed competition.

A. The ApHC shall recognize and award merits in any event that is sanctioned and supervised by an established record-keeping equine related governing body or specialty association such as the National Cutting Horse Association and 4-H, overseeing an outside event such as barrel racing, showing, roping, gaming and the like and concerning which a representative of the sanctioning association will verify the awards earned by horses registered with the ApHC. Credits from other breed associations or registries will not count. This representative may be asked to supply records for up to one year from the date of the event.

1. Owners of horses enrolled in ACAAP may be asked to provide information about associations or organizations that approve/sponsor events in which the owner is participating.

B. ACAAP merits cannot be earned at any ApHC-approved show or event, or at any show approved by another breed registry **unless the classes are designated as open all-breed classes. Classes that are specific to ApHC-registered horses or other registered breeds are ineligible for points.** This program is designed for events outside the approved show ring.

- C. Any registered Appaloosa (regardless of registration type) is eligible to compete for ACAAP merits.
- D. An enrollment form must be completed annually for each horse competing in this program. The annual enrollment fee is \$25 (members) and \$50 (non-members), allows participation from January 1 through December 31 and covers the processing fees for submitting show results from the first ten (10) shows at which each enrolled horse is exhibited. The enrollment fee is based on the membership status of the owner. If the horse is jointly owned, one owner must be a member to enroll at the member fee. The first listed owner according to ApHC records will be listed on the enrollment card.
- E. The enrollment application and annual enrollment fee must be returned to the ApHC. Upon receipt, an enrollment card and exhibitor forms will be forwarded to the horse's owner. Should a horse's owner wish to sign up for ACAAP while at an open competition, they must make sure the show secretary/manager signs and dates the enrollment form at the bottom, and the enrollment form and enrollment fees MUST be submitted along with the ACAAP exhibitor's report within 30 days.
- F. The show secretary/manager must inspect the enrollment card, or ApHC membership card of the owner, along with a copy of the horse's Certificate of Registration to verify the exhibitor's participation on a registered Appaloosa, and sign the exhibitor's report form on the last day of competition after the class is complete verifying the exhibitor's placing and the number of entries. The exhibitor and owner must also sign the report form and return it to the ApHC postmarked within thirty (30) days of the show.
1. Submission of results for up to and including 10 shows/judges is included in the enrollment fee.
 2. Submission of show results in excess of 10 shows/judges requires payment of a \$2/show/judge processing fee.
 3. All exhibitor reports and the appropriate fees must be received by December 31 of the year competing.
- G. Horses may compete in more than one class per show; however, only one processing fee per horse per show is due. Credit vouchers may be purchased and submitted with your show report rather than paying a processing fee each time you turn in a report. Each credit voucher is valued at \$2 and expires on December 31 of each year. Processing fees are only required if you submit more than 10 show/judge's results per year.
1. In multi-judged events (in which more than one judge places the entire class or ride,) you may turn in your placings under each judge. Each judge counts as a separate show and requires a separate processing fee.
 2. In multi-judged events where scores are combined for one overall set of placings, you may only submit the final placing. This would count as one show and would only require one processing fee.
 3. If a horse receives a placing in more than one division for the same ride or class, (i.e. 4th of 10 in the class and 1st of 4 non-pros in the same class) the owner/exhibitor may choose which placing they wish to submit but may not submit more than one placing for the same ride or class. In this case, only one processing fee is due.
 4. Merits earned in the 4-H category (in classes designated exclusively for 4-H members) may be applied to other categories provided that an additional processing fee per horse per show is submitted.
- H. Horses will earn merits based upon the number of horses exhibited in a class, whether or not an elimination round is held. Example: If 50 horses are entered and exhibited in elimination rounds with only 15 advancing to the final round, merits are based upon the total number of entries; in this case, 50.
1. If more than 50 horses are exhibited in a class and the class is held in go-rounds and a final, exhibitors have the option of submitting their placing in two ways: 1) submit placing in the final only counting the total number of horses exhibited against. Example: A total of 150 horses competed and you were 2nd or 2) submit placing for each go-round and final, including only the

horses you actually competed against. Example: In the 1st go there were 50 horses and you were 2nd and then in the final you were 4th out of 30 horses.

- I. Corrections to merit tabulations must be made by Dec. 31 and can only be made for merits earned in the current year.
 - J. Merit tabulating methods:
 1. Merit Tabulation for all categories except those detailed in J.2-J.5:

# of horses	1st	2nd	3rd	4th	5th	6th	7th
2	½						
3-7	1	½					
8-12	2	1	½				
13-17	3	2	1	½			
18-22	4	3	2	1	½		
23-27	5	4	3	2	1	½	
28 & Over	6	5	4	3	2	1	½
 2. Merit tabulation for 4-H classes if judged Danish:

Purple ribbon2 merits *

Blue ribbon.....1 merit

Red ribbon½ merit

White ribbon0 merits

If the 4-H Danish System does not apply, merits are earned using the table based on the number of entries. However, merits cannot be earned under both systems for the same class.

* Medallion classes will not replace purple ribbons.
 3. Merit tabulation for Combined Training and Combined Driving: Merits may only be earned at combined training and combined driving events when there are three or more entries. In order to earn merits for any placing, you must place above at least one other entry.
- TRIALS (or One-Day Events)
- | | |
|-----------|----------|
| 1st place | 5 merits |
| 2nd place | 4 merits |
| 3rd place | 3 merits |
| 4th place | 2 merits |
| 5th place | 1 merit |
- TWO-DAY EVENTS
- | | |
|-----------|-----------|
| 1st place | 12 merits |
| 2nd place | 9 merits |
| 3rd place | 7 merits |
| 4th place | 5 merits |
| 5th place | 4 merits |
| 6th place | 3 merits |
| 7th place | 2 merits |
| 8th place | 1 merit |
- THREE-DAY EVENTS
- | | |
|-----------|-----------|
| 1st place | 16 merits |
| 2nd place | 12 merits |
| 3rd place | 10 merits |
| 4th place | 7 merits |
| 5th place | 6 merits |
| 6th place | 5 merits |
| 7th place | 4 merits |
| 8th place | 3 merits |

4. Merit tabulation for Judged Trail Rides:

# of horses	1st	2nd	3rd	4th	5th	6th	7th	8th	9th	10th
2	½									
3	1	½								
4	1½	1	½							
5	2	1½	1	½						
6	2½	2	1½	1	½					
7	3	2½	2	1½	1	½				
8	3½	3	2½	2	1½	1	½			
9	4	3½	3	2½	2	1½	1	½		
10	4½	4	3½	3	2½	2	1½	1	½	
11+	5	4½	4	3½	3	2½	2	1½	1	½

5. Merit tabulation for Dressage

Introductory, Training, First and Second Levels (including Musical Freestyle)

This system is used regardless of the number of entries, but in order to receive credits, the horse must receive a score of at least 55%.

	USEF/USDF Recognized Shows	Other Shows
80-100%.....	6 merits.....	3 merits
75-79.9%.....	5 merits.....	2½ merits
70-74.9%.....	4 merits.....	2 merits
65-69.9%.....	3 merits.....	1½ merits
60-64.9%.....	2 merits.....	1 merit
55-59.9%.....	1 merit.....	½ merit

Third and Fourth Levels (including Musical Freestyle)

This system is used regardless of the number of entries, but in order to receive credits, the horse must receive a score of at least 55%.

	USEF/USDF Recognized Shows	Other Shows
80-100%.....	8 merits.....	4 merits
75-79.9%.....	7 merits.....	3½ merits
70-74.9%.....	6 merits.....	3 merits
65-69.9%.....	5 merits.....	2½ merits
60-64.9%.....	4 merits.....	2 merits
55-59.9%.....	3 merit.....	1½ merits

FEI Levels

(Prix St. Georges, Intermediate I and II, USEF International Tests, Grand Prix, Grand Prix Special and Musical Freestyle at these levels. This is to include all FEI Young Riders tests.)

This system is used regardless of the number of entries, but in order to receive credits, the horse must receive a score of at least 55%.

	USEF/USDF Recognized Shows	Other Shows
80-100%.....	10 merits.....	5 merits
75-79.9%.....	9 merits.....	4½ merits
70-74.9%.....	8 merits.....	4 merits
65-69.9%.....	7 merits.....	3½ merits
60-64.9%.....	6 merits.....	3 merits
55-59.9%.....	5 merits.....	2½ merits

In addition, the ApHC will recognize the highest placing horse within the Dressage category competing at 1) Introductory, Training, First and Second Levels; 2) Third and Fourth Levels; 3) FEI Levels.

6. Team Penning/Team Sorting: Merits will be calculated for all ACAAP-enrolled horses on each team. Exhibitors may only submit results for up to three goes on any one day. Exhibitors competing in this category should request a revised exhibitor report form and submit results on the current form.

7. Merits earned in any category may not be transferred to another category. Merits cannot be earned by using the same class in two or more categories. Exception: merits earned in the 4-H category (in classes designated exclusively for 4-H members) or in the Challenged Riders category (in classes designated exclusively for the disabled rider) may be applied to other categories provided that an additional processing fee per horse/per show is submitted.

K. At the ApHC's discretion, some events may warrant merits being earned for completion only. Other criteria for earning merits may be established or amended by the ApHC Show Department. For details contact the ApHC Show Department.

L. AWARDS

Awards will be mailed to the first-listed owner as evidenced by ApHC records on December 31 of the qualifying year. Owners do not have to be members to enroll in ACAAP; however, one owner must be a member in order to receive any awards and/or certificates earned.

1. Certificate of Achievement (COA) — Horses are awarded the COA when they have earned 20 merits in any one ACAAP category. Only one will be awarded per horse/per category.
2. Certificate of Superior Achievement (COSA) — Horses are awarded the COSA when they have earned 60 merits in any one ACAAP category. Only one will be awarded per horse/per category.
3. Certificate of Lifetime Achievement (COLA) — Horses are awarded the COLA when they have earned the prescribed number of merits listed below in any one ACAAP category. Only one will be awarded per horse/per category. Awards shall not be awarded retroactively.

Barrel Racing.....	400
Combined Training.....	300
Cutting.....	300
Dressage.....	300
Driving.....	200
English Equitation.....	300
English Pleasure.....	300
Games.....	500
Halter.....	300
Judged Trail Riding.....	300
Over Fence.....	300
Reining.....	200
Roping.....	200
Showmanship.....	300
Team Penning.....	500
Trail.....	300
Western Equitation.....	300
Western Pleasure.....	500
Western Riding.....	200
Working Cow Horse.....	100
4-H.....	300
Challenged Riders.....	100

4. A certificate for ACAAP versatility champion will be awarded when a horse has earned five Certificates of Superior Achievement (COSAs) in five different ACAAP categories. Awards shall not be awarded retroactively.

5. ACAAP Master — The ApHC will present annual awards based upon the number of merits earned by any individual horse during the calendar year from January 1 through December 31 in each individual category of approved events. The horse that earns more merits than any other horse competing in that category will be named the ACAAP Master for that category for that year.

- a. To qualify for any ACAAP Master title, the horse must have earned at least ten (10) merits in that category during the year.
- b. Ties for ACAAP Master in each category will be broken in the following manner: 1) the horse competing in the greatest number of shows, then 2) the horse defeating the greatest number of entries, then 3) the horse competing in the greatest number of ACAAP categories.

M. OFFICIAL PERFORMANCE RECORD

1. Merits earned through ACAAP will be added to the performance record of the competing horse regardless of the membership status of the owner.

N. APPROVED CATEGORIES

Listed below are the categories approved for competition in ACAAP. If the owner competes in an event not included below, a request may be made that the event be included by writing to the ApHC Show Department. If request is granted, the event will not be added until the following year.

1. Barrel racing - Restricted to cloverleaf. Includes WPRA and NBHA approved events or events sponsored by your local amateur association.
2. Combined Training - Includes USCTA-approved events.
3. Cutting - Includes NCHA, ACHA and CCHA-approved events, or events sponsored by your local amateur association.
4. Dressage - Includes USDF and USEF-approved events
5. Driving - Includes pleasure driving and ADS-approved events.
6. English Equitation - Includes English style equitation, English horsemanship, walk-trot equitation, and equitation over fences.
7. English Pleasure - Includes bridle path hack, hunter under saddle, English pleasure, walk-trot English pleasure, English style longe line, and hunter go-as-you-please.
8. Games - Includes local, state or national gaming events including pole bending, stakes race, flag picking, speed (straight) barrels, keyhole, ring race and other gaming events. Limited to one-person events. Team events are not included. (Cloverleaf barrels do not count in the games category).
9. Halter - Includes halter and in-hand classes.
10. Judged Trail Riding - Includes all non-breed association-sponsored competitions. Includes judged trail rides and hunters' pace and ACTHA events.
11. Over Fence - Includes hunter hack, working hunter, cavaletti, and all variations of jumping except equitation over fences.
12. Reining - Includes snaffle bit, hackamore, open and NRHA-approved events or events sponsored by your local amateur association.
13. Roping - Includes team roping, heading, heeling, tie-down roping, breakaway roping and all events sanctioned by the PRCA, NHSRA, USTRC, NIRA, NARC, WPRA, INRA or events sponsored by your local amateur association.
14. Showmanship - Includes English and western style showmanship and fitting & showing.
15. Team Penning/Team Sorting - Includes all non-breed association-sponsored events. Includes penning and sorting.
16. Trail - Includes all non-breed association-sponsored competition and in-hand trail.
17. Western Equitation - Includes western style equitation, western horsemanship, and walk-trot equitation.
18. Western Pleasure - Includes all non-breed association-sponsored events, including NSBA-approved events, Western style longe-line, and walk-trot western pleasure.
19. Western Riding - Includes all non-breed association-sponsored competition.

20. Working Cow Horse - Includes NRCHA-approved events or events sponsored by your local amateur association.

21. 4-H - Includes all classes strictly for 4-H members.

22. Challenged Riders – Includes all judged classes and/or exhibition-only shows and events designated exclusively for the disabled rider and sanctioned or approved by a nationally recognized organization such as NARHA. Horses in exhibition-only classes will receive 1 merit for participation. Horses in judged classes will be awarded merits based upon their placing and total number of entries according to the sliding scale in J.1.

For information on Appaloosas in Trail or Competitive Trail Riding and Endurance Riding Programs, Cutter and Chariot Racing, Disabled Riders and Driver Program and Saddle Log, please see the rules contained in this handbook.

O. Events that may be recognized include, but are not limited to, those sponsored or sanctioned by the National Cutting Horse Association (NCHA), Canadian Cutting Horse Association (CCHA), National Reining Horse Association (NRHA), National Reined Cow Horse Association (NRCHA), Women's Professional Rodeo Association (WPRA), Professional Rodeo Cowboys Association (PRCA), National High School Rodeo Association (NHSRA), National Intercollegiate Rodeo Association (NIRA), United States Equestrian Federation Shows (USEF), United States Combined Training Association (USCTR), United States Dressage Federation (USDF), American Competitive Trail Horse Association (ACTHA), and national, regional or local 4-H events, etc. Merits earned in any other breed association or registry do not count.

P. Any member, non-member, owner or exhibitor who gives false information to the ApHC may be subject to disciplinary action, and may be denied all privileges of membership associated with the ApHC and/or denied right to any and all awards earned in ACAAP.

Q. The Appaloosa Horse Club reserves the right of final approval of all events and/or classes.

Rules 421-449 are not assigned.

450. DISTANCE PROGRAM

The Distance Program includes Competitive Trail Riding and Endurance Riding, Saddle Log Program, Disabled Riders and Drivers Program, Year-end High Mileage Awards, 1,000 Mile Awards, Distance Medallion Program, and the Chief Joseph Commemorative Award Program.

A. All persons, as well as owners and riders of horses enrolled in any Distance Program, must be current ApHC members for each year hours and/or miles are to be accumulated and recorded. If there are multiple owners, at least one owner must be a current member. To enroll a horse and/or individual in any distance program, an application and appropriate fees must be completed and returned to the ApHC for each program.

B. No credit for mileage accumulated and/or hours spent riding prior to enrollment will be given nor will records be kept on any horse or rider prior to enrollment in any distance program in any calendar year.

C. Once enrolled in any program, each participant must maintain their own results and records on the official ApHC forms. All distance records will be maintained in the horse's permanent performance record starting in 2006. All saddle log hours will be maintained in the customer file for each enrolled member starting in 2006.

451. APPALOOSA SADDLE LOG

A. This system recognizes the need for personal achievement for the individual who daily or weekly enjoys the benefits gained from riding whether it be on the trails, training for and competing in shows, parades, ranch work, etc.

- B. On an honor system, each rider will keep his or her saddle log time or actual hours spent riding. The rider is not required to own the horse(s) ridden, but all horses used must be registered Appaloosas. All registration designations are eligible. The riding time is to be kept on an official log sheet provided by and available from the ApHC. Any type of riding counts.
- C. Awards will be given for successful completion of 100, 200, 500, 1000 and each 1000-hour plateau thereafter for hours ridden.
- D. Upon completion of 10,000 hours, the participant will be eligible for a commemorative buckle. ApHC will pay \$50 toward the purchase of the commemorative buckle with the recipient responsible for the remaining associated costs.**
- E. All log sheets must be completed by the participant and submitted to the ApHC when an award level is reached or when the log sheet is complete; whichever comes first.

452. DISABLED RIDERS AND DRIVERS PROGRAM

The ApHC has a special program for riders/and or drivers who are disabled. Any type of riding or driving can be recorded for this program. On an honor system, each rider/driver will keep his or her actual hours spent riding and/or driving.

The rider/driver is not required to own the horse(s) ridden/driven, but all horses used must be registered Appaloosas. All registration designations are eligible. The riding/driving time is to be kept on an official log sheet provided by and available from the ApHC. Any type of riding/driving counts. Awards will be given for successful completion of 25, 50, 75, 100, 200, 500, 1000, 1500, 2000 and 2500 hours.

453. CHIEF JOSEPH COMMEMORATIVE AWARD

- A. An Award will be given to individuals successfully completing 1,000 saddle log hours, 10 approved endurance rides and 10 approved competitive trail rides. Novice rides and double mileage will not count toward this award.
- B. Rider and horse must have been enrolled in the Distance Program in those years reflected on the log sheet submitted.
- C. Award may be earned multiple times.

454. COMPETITIVE TRAIL RIDE AND ENDURANCE PROGRAM

- A. All Appaloosas must be registered with Regular (#) or CPO (CN) registration classification or have been issued a Performance Permit prior to the qualifying ride year. All Appaloosas must be a minimum of 4 years old based on actual foaling date to qualify for a ROM and must be a minimum of 5 years old based on actual foaling date to qualify for a medallion. See DISTANCE PROGRAM for membership requirements.
 - 1. In order to participate in endurance rides, horses must meet age requirements for endurance and limited distance competition as established by AERC guidelines.
 - 2. In order to participate in competitive trail rides, horses must meet age requirements as established by ApHC-approved competitive trail riding organizations as listed in rule 454.D below.
- B. The ride year begins December 1 and ends November 30 of the following year. Owners may choose competitive trail riding, endurance riding or both in which to earn mileage.
- C. Horses are entitled to earn a distance trail medallion upon completion of 350 endurance miles or 350 competitive trail miles within the ride year. A horse may earn multiple distance trail medallions in its lifetime.
 - 1. Although a horse can compete in both disciplines, endurance and competitive miles cannot be combined to achieve medallion status.
 - 2. Endurance rides of 50 miles or more will count toward medallion status. Limited distance endurance ride mileage will be recorded on the horse's performance record but does not count toward medallion status.

- 3. Competitive trail rides of 25 miles or more per day, or 50 miles or more for 2 or more days, will count toward medallion status. Competitive trail rides of less than 25 miles and novice competitive trail rides will be recorded on the horse's performance record but will not count toward medallion status.
- D. Rides sanctioned by the American Endurance Ride Conference (AERC), Great Lakes Distance Riding Association (GLDRA), Upper Midwest Endurance and Competitive Ride Association (UMECRA), International Arabian Horse Association (IAHA), Appaloosa Distance Riders Association (ApDRA), North American Trail Ride Conference (NATRC), Eastern Competitive Trail Ride Association (ECTRA), Southeastern Distance Riders Association (SEDRA), Dutch Endurance Riders (DER), Netherlands Noreniging Lande Afstands Ruiters (NVLr), the Swedish National Equestrian Association, Ontario Competitive Trail Riding Association (OCTRA) and Middle of the Trail Distance Riders Association (MOTDRA) are approved by the ApHC. The ApHC also reserves the right to approve any other distance rides it deems suitable.
- E. Trail and Distance medallions will be awarded to horses that meet requirements listed in E.1 and E.2 below. Large medallions are awarded to the horse, smaller replicas are presented to the owner and breeder provided they meet all membership requirements. Refer to MEDALLION AWARDS SYSTEM for further explanation of rules regarding the medallion program.
 - 1. Distance medallions are awarded annually to horses completing 350 endurance or 350 competitive trail miles within the ride year (which starts December 1 and ends November 30 of the following year).
 - 2. Trail medallions will be awarded the horses completing 1,000 recreational trail riding miles. In order to earn miles toward the medallion, horses must be enrolled in the Distance Program. See Rule 458 for additional requirements.
- F. It is requested that all ride result sheets be submitted to the ApHC office within 10 days after the last day of the ride; however ride results must be submitted no later than December 15th after the end of the ride year for a horse to be eligible to receive distance awards. Official ApHC ride report forms must be used. "Best Condition" winners for endurance rides and "Sweepstakes" or "High-point" winners for competitive trail rides should be noted, as double mileage is applied toward medallions for these special awards. Double mileage will not be applied toward any other awards. Ride result sheets will be checked for accuracy against ride results from the sanctioning organization.
- G. A photograph suitable for publishing of horses that receive Medallions or High-mileage Awards must be received by December 15th for use in the Yearbook and/or *Appaloosa Journal*. It is the sole responsibility of the participant to submit ride results and photographs.
- H. A Register of Merit will be awarded for completion of 250 miles of approved endurance, limited distance and competitive trail rides, separate or combined, consisting of rides 25 miles or longer, over the lifetime of the horse. Only miles completed from 2006 and forward will be used for calculation of this award. Double mileage does not count toward this award.
- I. Beginning Dec. 1, 2009, a Superior Event Award shall be awarded for completion of 500 miles of approved endurance, limited distance and competitive trail rides, separate or combined, consisting of rides 25 miles or longer, over the lifetime of the horse. Only miles completed from December 1, 2009 and forward will be used for calculation of this award. Double mileage does not count toward this award.
- J. A National Championship Endurance Ride will be approved. The championship ride may be held in conjunction with an existing approved ride. The ApHC will award a championship trophy and the horse will be titled a National Champion.
- K. Awards will be mailed to the current first-listed owner on record with the ApHC as of December 31 of the year earned.

- L. A Competitive Trail Ride is defined as a competition in which participants cover a marked course within a given window of time; no less than 25 miles for a one-day event or 30 miles for a two-day event. The presence of a licensed veterinarian judge is required. The veterinarian will judge and monitor the equine competitors according to the sanctioning organization's parameters. Horsemanship judges may also be present, with the sole responsibility to judge the riders.

455. 1,000 MILE AWARD

- A. The 1,000 mile award is for the endurance or competitive trail Appaloosa. It is awarded every 1,000 miles to horses completing mileage in approved endurance or competitive trail rides. Mileage from one category does not count toward the other. All Appaloosas must be registered with Regular (#) or CPO (CN) registration classification, or have been issued a Performance Permit prior to the qualifying ride year, and must be a minimum of five (5) years old. All horses competing for the 1,000 Mile Award must be owned by a current ApHC member.
- B. This award was designed to encourage the serious conscientious rider, and to recognize those Appaloosas able to reach a high level of performance in the distance field. There is no time limit on completing the mileage.
- C. The same rides approved for medallions will also count for 1,000 mile credit. The rider is responsible for keeping the same type of records required for the medallion award. No double mileage will be given. The official log sheet must be completed by the participant and received by the Appaloosa Horse Club along with a photo of the horse, if applicable, on or before December 15 for mileage completed in that year for horses to become eligible to receive awards. Log sheets will be double checked for accuracy against official ride results that have been submitted.

456. YEAR-END HIGH MILEAGE AWARDS QUALIFICATIONS

- A. In order to be eligible for these awards, the horse must be enrolled in the Appaloosa Horse Club Distance Program and must meet all program qualifications.
- B. Beginning Dec. 1, 2009, double mileage will not be given for winners of overall "Best Condition" for Endurance rides or high-point/sweepstakes for Competitive Trail rides.
- C. A minimum of 350 miles must be completed before the award will be given.
- D. Mileage ties will be broken by presenting the award to the horse with the highest number of actual rides.
- E. Year-End High Mileage Endurance Horse Award - To be presented to the horse enrolled in the ApHC distance program completing the highest number of miles in approved endurance rides within a ride year.
1. A year-end jacket will be awarded annually to the Year-End High-Mileage Endurance Horse at the American Endurance Ride Conference banquet.
- F. Year-End High Mileage Competitive Trail Horse Award - To be presented to the horse enrolled in the ApHC distance program completing the highest number of miles in approved competitive trail rides within a ride year.
- G. High Mileage Horse of the Year Award - To be presented to the horse enrolled in the ApHC distance program completing the highest total combined number of miles in approved endurance and competitive trail rides within a ride year.

457. CHIEF JOSEPH TRAIL RIDE MEDALLION

- A. Commencing in 1993 and thereafter, a medallion will be issued to eligible horses completing 10 consecutive years of each entire annual ride of the Chief Joseph Trail Ride. Medallions will be awarded to the first-listed owner according to ApHC records at the time the 10-year requirement is completed. No ride prior to 1993 shall count toward the Chief Joseph Trail Ride medallion. Award may be earned multiple times.
- B. Commencing in 1997 and thereafter, a plaque shall be awarded for any horse that completes thirteen Chief Joseph Trail Rides whether consecutive or non-consecutive.

458. RECREATIONAL TRAIL RIDING AWARDS

Annually, the ApHC sponsors several National trail rides and approves several Regional trail rides throughout the United States.

- A. In order to earn miles toward the following awards, horses must be enrolled in the Distance Program, the owner of the horse must be a current ApHC member and the horse must be ridden at ApHC-sponsored or -approved regional trail rides where mileage is recorded (beginning in 2006). Miles credit will not be granted retroactively.
1. A Register of Merit will be awarded to a horse that has completed 400 miles.
 2. A Superior Event award will be awarded to a horse that has completed 800 miles.
 3. A medallion will be awarded to a horse that has completed 1,000 miles.

459. TRAIL RIDE CLASSIFICATIONS:

The following guidelines define aspects of the ApHC-approved trail-riding program. See Rule 460 for approval guidelines.

A. National Trail Rides:

1. Sponsored and conducted by the ApHC. Examples include the currently held Chief Joseph, Apache Land, Land of Liberty and Sheltowee annual trail rides.
2. All aspects of trail ride managed by ApHC or their designated representative.
3. Participants may or may not be required to ride ApHC-registered Appaloosas, but in order for riders to be eligible for annual or lifetime ApHC awards (if any), they:
 - a. Must ride an ApHC-registered Appaloosa; and
 - b. Must enroll in the ApHC Distance Program; and
 - c. Must be a current-year ApHC member when mileage credit is earned.
4. On the Chief Joseph Trail Ride, participants are required to ride ApHC-registered Appaloosas.
5. On ApHC National trail rides, all participants must be current ApHC members.

B. Regional Trail Rides:

1. Managed and/or sponsored by a regional club or otherwise approved organization or individual ApHC member.
2. Ride is not managed or controlled by ApHC.
3. Must abide by regulations contained in the ApHC Trail Ride "Handbook of Safety Information and Rules."
4. ApHC members may submit mileage from a regional trail ride if the ride is at least 3 days in duration and if the horses are enrolled in the ApHC Distance Program prior to the ride. The ride manager must certify, by signing the mileage form supplied by the rider, that the mileage submitted by each rider is accurate (eg: the manager will certify all daily miles and also that the mileage submitted is consistent with what the horse completed on the ride).
5. Participants may or may not be required to ride ApHC-registered Appaloosas, but in order for riders to be eligible for annual or lifetime ApHC awards (if any), they:
 - a. Must ride an ApHC-registered Appaloosa; and
 - b. Must enroll in the ApHC Distance Program; and
 - c. Must be a current-year ApHC member when mileage credit is earned.

460. TRAIL RIDE APPROVAL REQUIREMENTS:

- A. To obtain trail ride approval, an application form supplied by the ApHC and accompanied by a nonrefundable application fee must be submitted to the ApHC. Said application must list the name of the trail ride, name and contact information for the trail ride manager or person who shall receive all correspondence, the date(s) and location of the trail ride.
1. Regional trail rides must submit an approval fee of \$25 with the completed application, all of which must be received in the ApHC office at least 100

days in advance of the ride. Applications submitted after this date shall not receive approval, as they cannot be published in *Appaloosa Journal*.

B. Release of Liability

1. The ApHC, and hosting organization, if any, will not be responsible for any accident that may occur to, or be caused by any horse ridden at the trail ride, or for any article of any kind or nature that may be lost or destroyed or in any way damaged. The ApHC will not be responsible for any financial arrangements not completed between trail ride management, participants, owners or official trail ride crew. However, these situations should be reported in their entirety to the ApHC for possible disciplinary action.
 2. It is recommended that each regional trail ride obtain blanket liability insurance to cover suits, claims, or judgments for bodily injury or property damage sustained by spectators, participants or others arising out of the use of the trail ride location or operation necessary or incidental to the trail ride.
- C. ApHC approval of a regional trail ride is a privilege, not a right, granted or rejected at ApHC discretion on an annual basis according to continuous evaluation of the application, including but not limited to competence of trail ride management, enforcement of ApHC rules (if any), quality of ride and service to ApHC members.
- D. If a trail ride approval application is satisfactory, the CEO will cause to be issued a statement of official approval of the proposed trail ride. If such application is unsatisfactory, the CEO will so inform the organization or individual making the application, giving the reason for disapproval.
- E. The ApHC shall publish the name, dates, trail ride location and trail ride contact information for all approved regional trail rides 30 days prior to trail ride in *Appaloosa Journal* and/or the ApHC web site and/or by electronic communication to ApHC members.

Rules 461-499 are not assigned.

500. GENERAL RULES FOR JUDGES

Designation as an ApHC-Approved judge is a privilege, not a right, bestowed by the Judges' Committee according to procedures formulated by it, to individuals whose equine expertise and personal character merit the honor. A judge shall judge an ApHC-approved and/or sponsored event in accordance with applicable rules, regulations, directives and guidelines of the ApHC. An individual's conduct as a member, exhibitor, and judge and his/her ability must be exemplary; is subject to continual Judges' Committee review; and such designation is revocable for cause by the Judges' Committee following notice and a formal hearing before the Judges' Committee to determine whether the judge's designation as an ApHC-approved judge should be revoked. A judge whose ApHC-approved judge's card has been revoked by determination of the Judges' Committee shall have the right only for thirty (30) days following any such determination to request, by written notice of appeal filed with the ApHC Chief Executive Officer that includes the basis for such appeal, that the ApHC Executive Committee review such determination. The ApHC Executive Committee shall determine whether it will review the matter and, if it decides to review the matter, whether the appeal will be reviewed based on the record of the proceedings before the Judges' Committee or whether a hearing will be held before the ApHC Executive Committee at which the judge may appear and present and refute testimony and evidence. The ApHC Executive Committee will issue its determination in regard to any such appeal and such determination shall be final and binding on all parties.

A. An ApHC judge's approved status will remain valid and in effect for a period of three (3) years. At the end of that period, each ApHC judge's approved status is subject to automatic review and disposition by the Judges' Committee. Upon such review a judge's approved status may:

1. be renewed as is for a successive period of three (3) years; or
2. be renewed for a shorter period with and/or without restrictions or provisions; or
3. not be renewed.

B. The Judge's Committee, in addition to any other valid ground or reason, may refuse to issue a card or may revoke the judge's card of any person:

1. Who has been convicted of a crime punishable by imprisonment in state or federal prison, or who has been convicted of a crime involving moral turpitude;
2. Who has made a material misrepresentation or false statement to the Judges' Committee or its agents in his or her application for a judge's card or otherwise, or who fails to answer any material question on the judge's application or in the judge's card process;
3. Who is suspended from or has been denied judging privileges in USEF, AQHA, NCHA, NRHA, APHA, ApHC, or any other recognized breed registry;
4. Who has committed any acts in connection with the horse industry which were fraudulent or in violation of a trust or duty;
5. Who has unlawfully engaged in or has been convicted of possession, use or sale of any narcotic, dangerous drug or marijuana;
6. Who has violated or who aids, abets or conspires with any person to violate any provision of the rules of the ApHC;
7. Who, after accepting a judging commitment, has not made all reasonable effort to judge such show or has not timely communicated to show management any inability to complete such commitment;
8. Who does not, at all times, conduct himself/herself in an exemplary and professional manner, such as not showing courtesy and respect towards show management, exhibitors and spectators and not wearing appropriate attire while judging an ApHC-approved or sponsored show.
9. Who is not physically able to move normally about the arena without aid in order to perform prescribed duties; or who must judge from a sitting position; or who does not have normal vision, corrected by eyeglasses or contact lenses, if necessary. Provided, however, that any person who is otherwise qualified to be an ApHC judge but for a disability recognized under the Americans with Disabilities Act ("ADA") shall not be denied status as an ApHC-approved judge.

C. Any person suspended by the ApHC for cause, except for temporary suspension without hearing, will be automatically removed from the list of approved judges and must reapply for approval in the usual manner. Removal of an individual from the ApHC's list of approved judges for any reason, including, but not limited to, suspension from membership, denial of ApHC privileges, or failure to comply with ApHC rules, shall be absolute, with no provision for automatic reinstatement. Upon regaining active membership status, the individual may apply for reinstatement of previously held judging status under the current procedures for admission of new applicants.

D. If a judge is removed from the ApHC judge's list due to temporary suspension without hearing, the judge may, after temporary suspension has been lifted, apply for reinstatement in the following manner:

1. Payment of a non-refundable fifty dollar (\$50.00) reinstatement fee;
2. Written statement declaring the reason or reasons that the judge failed to make said payments before the same became delinquent;
3. The Chief Executive Officer may, after payment of the requisite fee and submission of the written statement, reinstate judges' status or the same may be submitted to the Judges' Committee at their next regular meeting for review and consideration.

E. However, anything contained herein to the contrary notwithstanding persons who have been subject to disciplinary action of record for two violations of ApHC Rules and Regulations shall be ineligible for the judge's designation, and it shall be incumbent upon the Judges' Committee to revoke a person's ApHC-approved judge's designation upon notification that the individual has been found to be in violation of the rules and regulations governing the ApHC and that such violation is of record.

F. In order to retain active judges' status, judges must:

1. Hold current membership in the ApHC. Dues for such membership are payable on January 1. Membership is required in order to appear on the approved judge's list.
2. Pay an annual judges' card renewal fee.
3. Attend an ApHC-approved judges' seminar once every three years.
4. Receive a passing grade on the annual rulebook written test.
5. Notwithstanding the above requirements to retain active judge's status, the **chairperson of the Judges' Committee** may, with approval of the CEO and Executive Committee, in consideration of exceptional circumstances, waive strict compliance with the requirements of Rule 500.F.3.

G. After acceptance of a judging commitment, a judge shall endeavor, with all reasonable effort, to judge the show.

1. Inability to judge: A judge shall timely communicate to show management any inability to complete commitment, so as to allow the show management adequate time in which to seek a suitable replacement.
 - a. Written explanation: Additionally, the judge shall immediately file with the ApHC written explanation of such inability to meet his/her commitment, specifying the date and manner in which he/she communicated to the show and with whom he/she communicated.
2. Arriving within the prescribed time: A judge upon arrival at the destination where he/she is to officiate, should contact an official of the show and advise him of his/her presence and location. A judge not arriving within the prescribed time frame without reasonable explanation may be subject to review and disciplinary action.
3. Judge unable to complete judging assignment at show: Any judge who is unable to complete his/her judging assignment at the show after arriving on the show grounds shall submit a written statement to the ApHC within 30 days. The show management shall select a suitable replacement and notify the ApHC in writing.

H. A judge shall not commit the following acts:

1. A judge shall not discuss with an exhibitor the purchase, sale or lease of any horse during a show or multi-judge show at which he/she is officiating.
2. No judge shall judge two shows or multi-judge shows within two hundred airmiles (321.87 km) of each other within 30 days.
3. A judge shall not have physical contact with horses or equipment while that judge is judging youth and non-pro showmanship classes, except in the case of emergency.
4. A judge shall not personally exhibit a horse, nor can a horse owned in whole or in part by the judge be exhibited at an approved show:
 - a. in the same state within seven days prior to when a judge is officiating a show in that state nor,
 - b. at the same location within seven days after a judge has officiated a show at that location.
5. Any judge who has been contracted to judge at any ApHC-sponsored event shall not be allowed to judge any ApHC-approved event **in North America** within **21** days prior to the ApHC-sponsored event (i.e. National and World Shows).
 - a. Judges who have been adjudicated guilty of violation(s) of ApHC rules will not be eligible to judge either the National or World Shows. Administrative action by the ApHC is not to be considered to be disciplinary action.
6. A judge shall not be an exhibitor, rider, driver, handler, steward, ring steward or manager at any show or multi-judge show in which he/she is judging, whether or not classes in which he/she judges are conducted under ApHC rules. A judge also shall not be an exhibitor, rider, driver, handler, steward, ring steward, or manager of any back-to-back or multi-judge shows in which he/she is judging one of the shows.

7. A judge may not officiate two consecutive years at the same show or multi-judge show, beginning in 1999.

8. Judges shall not intentionally solicit, without prior invitation, any judging assignment.

9. Judges are prohibited from using tobacco and/or alcohol products, cellular phones, pagers or electronic communication devices for personal use in the arena during an approved show.

I. Judges are required to provide written notice to the Judges' Department by certified mail or other guaranteed delivery service, of any address or telephone number changes within thirty (30) days of such changes. In the event that any notice is not given, the judge shall bear all consequences of such failure.

J. A judge (or judges) shall present in writing any grievance that he/she may have against contestants or shows to the secretary or appointed representative of the sponsoring association at the time of the grievance, and forward a copy to the ApHC, and his/her case will be reviewed by the Legal & Disciplinary Committee.

K. The judge must comply with rules governing individual classes. The formula for judging percentages used for each section will be found in the sections of this handbook covering individual classes and events.

L. Judges must place the top eight entries in each class except in classes of fewer than eight entries or in instances of lack of merit; and if without merit, the judge shall make no award under any circumstances. No class is complete until all ties through point-earning placings are broken. If a tied contestant is disqualified in the run-off, (s)he is not to be placed any lower than the lowest position for which (s)he was tied. Contestants disqualified during the first run are not considered to be tied for a place even if there were fewer than eight entries in the class.

M. The judge at his/her discretion may refuse entry into the arena for improper attire or equipment. Further, a judge may eliminate any horse or exhibitor as an entry which he/she does not feel has legitimately attempted to comply with the class rules and procedures. In such case, this entry would not be counted as an entry for the purpose of determining the number of entries in the class for national points.

N. Judging begins when the entrant enters the arena and ends when all judging is complete. After a judge has placed a class and signed the judge's card, a class will not be re-judged and the judge's record shall not be changed. If clerical corrections, initiated by show official(s) (typically announcer, but could also be show secretary, manager or ring steward) are made to a judge's card, they must be approved and initialed by the judge. Once a judge's placings have been announced, no clerical corrections shall be made.

O. No judge shall determine the eligibility for registration of any entry in the ring and shall at all times refrain from making comments regarding such.

P. ApHC Judges should be sensitive to any conflict of interest between the ApHC's objective and their own personal business. Each judge should refrain from using his or her official status to further one's own personal or financial purpose.

1. Neither the judge nor members of his/her family nor any cohabitant, companion, domestic partner, housemate or member of a judge's household nor any of the judge's clients, employers or employees or employees of a member of the judge's family shall exhibit or act as agents, representatives in any capacity, or handlers of a horse in any approved class at a show or multi-judge show at which he/she is officiating. Members of the judge's family shall not be present in the arena during judging. A ring steward at any show shall not be a member of the immediate family of the judge of that show.

2. No judge may judge a horse, and no horse may be shown under a judge, if that judge has been owner, trainer, agent in any capacity, or conditioner of that horse within the previous 90 days.

- a. Notwithstanding the above, no judge may show a horse at the National Show and then judge the same horse at the World Show.

3. A judge shall not judge a horse which is owned by anyone from whom the judge has received a salary, commission, or any kind of remuneration for

selling or buying any horse for that individual; or, whether or not a horse is concerned in the transaction, has been in the employ, or has represented such individual in any capacity for remuneration, within **90** days from the date of the subject. An individual who assists an exhibitor as helper in Grand and Reserve Champion, Get of Sire, Produce of Dam, Hunter in Hand or driving classes is excluded from this rule. The official exhibitor is the individual who handled, rode or drove the horse in the qualifying classes.

4. No judge may judge a horse belonging to, or being exhibited by, any member of the judge's family.
 5. These specified areas of disqualifying conflict of interest are not exclusive and ApHC Judges are ineligible to judge another's horse in other situations not designated by the rule. If a judge cannot exercise his/her objective opinion, free from possible prejudice, bias, or outside influence, because of his/her connection with an owner, exhibitor or anyone else connected with the horse, or, for that matter, if such connection would appear to others of possible bias, whether or not the judge feels he/she would be affected, a judge must disqualify himself.
 6. In a multi-judge show, if a judge is confronted during a class with an entry that poses a conflict of interest, the judge shall not judge that entry. The remaining judge(s) shall judge that entry and that entry will be counted towards the total number of horses in the class. The judge with the conflict shall mark his/her card, note the total number of entries (including the entry that posed a conflict) and must make a notation on his/her card that the entry is a conflict.
- Q. A judge's decision will be considered final. A judge's decision, representing his or her individual preference is not protestable unless it is alleged to be in violation of the rules.
- R. Each judge shall be responsible for independently tallying the correct number of entries actually exhibited in each class he/she judges and marking the correct totals on a form provided by the ApHC. It is the judge's responsibility to complete, sign and return this form to the ApHC within ten days from the show date.
- S. A judge shall not appear on the show or contest grounds prior to 30 minutes before judging. A judge shall not visit in the horse barns, nor with the owners, nor inspect or discuss any horse entered in the show or contest before judging.
- T. The sponsor and/or management of any ApHC-approved and -sponsored shows or events shall make reasonable accommodation, as determined by the ApHC, for any ApHC judge having a disability recognized under the Americans with Disabilities Act ("ADA"). Any judge having a disability recognized under the ADA must (i) inform show management of such disability prior to accepting an offer to judge any such show or event and (ii) contact the ApHC Judges Coordinator prior to judging any such show or event to discuss what reasonable accommodation, if any, can be made and will so notify show management. In the case of any judge whose disability under the ADA prevents him or her from walking without aid or requires him or her to sit while judging, the reasonable accommodation shall require the judge to judge from outside the show ring so as not to constitute a significant risk to the safety of himself/herself, other persons and/or horses in the show arena.

501. COMPLAINTS AGAINST JUDGE

- A. To make a formal complaint against an ApHC-approved judge, such complaint must be in writing, signed by the complainant, contain alleged rule violations, date and location of such violation and be submitted to the ApHC office within thirty days of the show or contest. By filing this complaint, the complainant agrees to attend a hearing conducted by the ApHC in regard to the matter either at the ApHC offices or as directed by the Judges' Committee.
- B. If a formal complaint is made against an ApHC-approved judge, the Judges' Committee is the forum within the ApHC which shall hear and review complaints alleging rule violations by ApHC-approved judges acting in their capacity as ApHC-approved judges. Proceedings before the Judges' Committee shall be conducted,

after proper notice, in like manner as disciplinary proceedings before the Legal and Disciplinary Committee. In addition to having a right to revoke designation as an ApHC-approved judge or to refuse to issue an ApHC judge's card, the Judges' Committee may impose on any person found to be guilty of any such violation hereunder such penalties as the Judges' Committee may determine, including but not limited to, those set forth in Disciplinary Procedure and General Violations. The decision of the Judges' Committee shall be binding and final on all parties.

- C. In the event that any judge at or during any show is guilty of gross misconduct or engages in belligerent or extremely disruptive behavior or is in such a physical, mental or emotional condition so as to substantially affect such judge's ability to judge properly, show management, in its sole discretion, shall have the right to prohibit such judge from judging the show and to remove such judge from the show grounds. The show manager shall, on the next business day, file a written report of any such incident to the ApHC.

502. SPECIALTY JUDGES

- A. The ApHC may grant a Specialty Judge's Permit to individuals holding judging credentials in the appropriate association for certain events. Such individuals are subject to all rules contained herein.
- B. The events and appropriate sanctioning associations covered by this rule are:
 1. English Performance Classes
 - a. USEF registered or recorded in Hunters/Jumpers.
 - b. USEF registered or recorded in Hunt Seat Equitation.
 2. Cutting - NCHA
 3. Reining - NRHA
 4. Snaffle Bit Western and Hunt Seat Pleasure - NSBA
 5. Working Cow Horse - NRCHA
- C. Applicants must certify their credentials in the appropriate association.
- D. Applicants for this permit must sign an affidavit attesting they have read, understand and agree to abide by the ApHC Handbook and that they are subject to all disciplinary rules contained therein.
- E. Specialty judges must be a member in good standing of the ApHC.

503. RULES FOR RING STEWARD

- A. It is recommended that the ring steward not officiate in any show in which he/she or a member of his/her family or any of his/her clients is an exhibitor. The ring steward shall be familiar with show procedures and etiquette.
- B. A ring steward at any show shall not be a member of the immediate family of the judge at that show.
- C. The ring steward makes the work of the judge much easier by relieving the judge of unnecessary details. By assembling the class promptly, he will be able to keep the judging program on schedule and eliminate long delays between classes.
- D. The ring steward will notify the judge when all horses are present for each class.
- E. Ring stewards shall not take part or seem to take part, in any of the judging including advising the judge. When he/she is not actively engaged in his/her duties, he/she shall place himself in a position so as not to interfere with the judging and the view of the spectators. He/she must not allow the exhibitors to crowd up in the ring or arena and should at all times endeavor to keep the possibilities of an accident at a minimum.
- F. He/she should act as a liaison between the judge and exhibitor. The ring steward should be prepared to move and place the horses as the judge advises.
- G. Ring stewards and/or scribes are prohibited from using tobacco and/or alcohol products, cellular phones, pagers or electronic communication devices for personal use in the arena during an approved show.
- H. Each organization shall provide one ring steward or assistant for every two judges. The same ring steward(s) may work with both an English and western or specialty judge.

Rules 504-599 are not assigned.

SHOW RULES & REGULATIONS

600. EXHIBITORS, JUDGES AND SHOW MANAGEMENT ARE RESPONSIBLE FOR KNOWLEDGE OF ALL ApHC RULES.

A. Release Of Liability

1. The ApHC, and co-sponsoring organization, if any, will not be responsible for any accident that may occur to, or be caused by any horse exhibited at the show, or for any article of any kind or nature that may be lost or destroyed or in any way damaged. The ApHC will not be responsible for any financial arrangements not completed between show management, exhibitors, owners or judges. However, these situations should be reported in their entirety to the ApHC for possible disciplinary action.
2. Each show should obtain blanket liability insurance to cover suits, claims or judgments for bodily injury or property damage sustained by spectators, or others arising out of the use of the show grounds or operation necessary or incidental to the show.

601. SHOW APPROVAL REQUIREMENTS

- A. The rules set forth in this *Official Handbook* shall be used at all approved shows. All shows approved by the ApHC for the awarding of points must be named, called, advertised, listed and otherwise referred to as an ApHC-approved show. All approved classes at an ApHC-approved show shall be conducted and judged in accordance with the rules of the ApHC. Classes that are not approved (such as futurities, maturities or stakes classes) and that are held concurrently with ApHC-approved classes shall be conducted and judged in accordance with ApHC rules. Futurities, maturities and stakes classes that are not held concurrently with ApHC-approved classes and/or classes open to all breeds shall be conducted at the discretion of show management and by rules and eligibility requirements determined by show management.
- B. Show approval is a privilege not a right, granted or rejected at ApHC discretion on an annual basis according to continuous evaluation of the applicant, including but not limited to competence of show management, enforcement of ApHC rules, quality of show and service to ApHC members.
1. Approval does not carry over from year to year and must be obtained for each individual show. The ApHC reserves the right to approve only the number of shows per calendar year it deems appropriate for the same organization or management.
 2. An ApHC-approved show having been held the previous year is considered an established show and has priority to reserve identical days per calendar week for the current year until terminated by the ApHC. Priority dates are a privilege, not a right, and therefore cannot be sold or transferred from one sponsoring body or management to another. Violation of this rule may result in disciplinary action.
 3. The sponsor of any ApHC-approved show which fails to pay for any service rendered by a third party (i.e. judges, cattle fees, facility fees, advertised premium money to exhibitors) in connection with the holding of an approved show will be denied ApHC approval for future shows until all fees are paid.
- C. Futurities, maturities and stakes classes and/or classes open to all breeds may be held at the discretion of show management, and such classes may vary from ApHC-approved or pointed classes as long as they are not held concurrently with ApHC-approved classes. If futurities, maturities or stakes classes are held concurrently with ApHC-approved classes, ApHC rules regarding show, judges, registration, discipline, class conduct, membership, horse, exhibitor and equipment restrictions and limitations shall apply. Futurities, maturities and stakes classes that are not held concurrently with ApHC-approved classes and/or classes open to all breeds shall be conducted at the discretion of show management and by rules and eligibility requirements determined by show management.
- D. Organizations, clubs or individuals desiring to sponsor or stage shows or contests which will be approved by the ApHC, and which will include the awarding

of national points to the top placing horses entered in the show, must obtain approval from the ApHC. Any non-ApHC member or organization, prior to obtaining show approval, shall agree in writing, to comply with ApHC rules in the conduct of such show and if requested by the ApHC, to provide evidence of financial responsibility of such show. ApHC show approval is also required to qualify horses for the World Championship Appaloosa Show. The ApHC offers approval for open, youth and non-pro nationally pointed shows.

- E. To obtain show approval, an application form supplied by the ApHC accompanied by a non-refundable application fee must be submitted to the ApHC. For shows sponsored by an ApHC regional club, the approval fee is \$25 per judge. For all other shows, the approval fee is \$25 per judge for ApHC members and \$50 per judge for non-members.
1. Show manager and show secretary must both be members of the ApHC in order for the sponsoring organization of the show to pay member fees for show approval.
- F. For shows which have been approved and held the previous year, and who wish to retain priority to reserve such previous year's show schedule as determined by the Show Department, the application for shows to be held January through May must be postmarked no later than September 15 of the year prior to the show, and applications for shows to be held June through December must be postmarked no later than January 15 of the year of the show. Said application must list the name of the show, show contact for all correspondence, the date(s) and location of the show, and must be accompanied by a list of classes. (Additional details on the application such as show manager, show secretary, ring steward, judge(s), and other information required by the ApHC must be forwarded and received by the ApHC at least 100 days prior to the first day of the proposed show.) Applications received later than the above dates but complete in all details and received by the ApHC at least 100 days prior to the first day of the proposed show will be accepted, but such shows will not retain priority to their previous dates, if any.
- G. Holidays, as such, will not be reserved as a priority day because a holiday falls on different days from year to year.
- H. No show and/or event may be approved on the same date as another approved show and/or event if the two shows and/or events are located within a 150 airmile (241.40 km) radius of each other, with the exception of shows existing prior to 1979. If all affected show managers agree to waive the 150 airmile (241.40 km) radius rule, shows less than 150 airmiles (241.40 km) apart will be approved.
1. State, regional and county fairs may be on the same date as another approved show for exhibitors of all ages, despite proximity.
- I. If a show approval application is satisfactory, the Chief Executive Officer will cause to be issued a statement of official approval of the proposed show. If such application is unsatisfactory, the Chief Executive Officer will so inform the organization or individual making the application, giving the reasons for disapproval. However, lack of approval for any certain class in a proposed show need not invalidate the approval of the remaining show.
- J. New shows do not have priority for date reservations. A new show is one never previously held. In addition, the following are considered new shows:
1. A show held in the prior year, but not ApHC-approved.
 2. A show approved and held the prior year which changes sponsoring body. The sponsoring body is the individual or group financially responsible for holding the show.
 3. A show that changes its name.
 4. A show that changes location over 100 miles (160.93 km).
 5. A show that changes its date(s).
- K. New shows must submit applications for approval to the ApHC office at least 100 days prior to the first day of the proposed show. **Said application must list the name of the show, show contact for all correspondence, the date(s) and location of the show, and must be accompanied by a list of classes. Additional**

details on the application such as show manager, show secretary, ring steward, judge(s), and other information required by the ApHC must be received by the ApHC at least 100 days prior to the first day of the proposed show.

- L. The ApHC recommends all approvals be sent certified mail, return receipt or other guaranteed receipted mail service.
- M. No show will be approved that has 2-year-old snaffle bit, yearling longe line and/or weanling halter class(es) prior to May 20.
- N. No shows will be approved during the period of December 21 - December 31.
- O. Except as provided in Rule 601(N), all classes to be offered at the approved show must be listed on the application, whether approved or not; and it must be indicated which classes are to be approved and which are to be non-approved.
- P. The ApHC shall publish the name, dates, show location, judges, show contact's name, address, phone number and e-mail address for the show at least 30 days prior to the show in *Appaloosa Journal* and/or the ApHC web site and/or by electronic communication to ApHC members. The ApHC shall publish the class list for the show **on the ApHC web site** at least 30 days prior to the show. **Additions to the list of classes may not be made within 30 days prior to the first day of the show; however, the ApHC shall publish such additions that are timely made and were not previously published on the ApHC website as soon as reasonably practical. Classes in the premium list or published on the ApHC web site must be held if there is an entry.**
- Q. All approved shows must use judge(s) from the ApHC Official Approved Judges list. Shows may use a judge with an ApHC Specialty Judge Permit per SPECIALTY JUDGES. The list of official approved and specialty judges is available upon request from the ApHC.
 - 1. The judge's name shall be published in all printed matter and information pertaining to the show.
- R. No more than four single judge shows or any combination of multi-judge shows, not to exceed four judges, may be held during a period of seven consecutive days at the same facility and/or grounds unless there are a minimum of four days off between the first held shows and/or events and the latter held shows and/or events, and the latter held shows and/or events commence no earlier than seven days after the commencement of the first held shows and/or events.
- S. Any show approval rule to the contrary notwithstanding, the ApHC Chief Executive Officer has the right, in his/her sole discretion, to approve any show and/or event which is not in conflict with any other approved show and/or event.
- T. Specialty Events
 - 1. Points may be earned at specialty shows approved by the ApHC and open only to registered Appaloosas that are eligible to show. Application for approval must meet all conditions per show approval requirements except:
 - a. There are no additional classes required as outlined in Rule 603, Rule 604.F and 604.H.
 - b. Specialty events do not retain priority for dates year after year.
 - 2. Specialty shows can be approved for games, jumping, reining or cattle classes.
 - a. All specialty shows must use judges from the ApHC Official Approved Judges list. In a multi-judged show (two or more judges), management may add one specialty judge who is not an ApHC judge, but who has an ApHC Specialty Judge Permit and meets requirements per SPECIALTY JUDGES (with the exception of cutting classes). The specialty judge must hold an NRHA, NRCHA, NCHA or USEF card. (See SPECIALTY JUDGES Rule 502). ApHC judge status is not a necessary requirement. For cutting classes, all judges must be NCHA judges, but do not have to have an ApHC Specialty Judge Permit.
 - b. Each specialty show must offer a minimum of three (3) classes from the list of approved classes for that specialty event.
 - 1. Shows must offer classes in all three divisions (open, youth, non-pro) if available, even if the class is a non-pointed optional class.
 - 2. If novice non-pro classes are offered, the show must hold the corresponding 19 & over non-pro class.

- c. A specialty show cannot hold additional ApHC-approved classes (such as western pleasure, hunter under saddle, halter etc.).
- d. For specialty events sponsored by an ApHC regional club, the approval fee is \$25 per judge. For all other specialty events, the approval fee is \$25 per judge for ApHC members and \$50 per judge for non-members.
- e. *Appaloosa Journal* must publish the name, date(s), specialty event location, judge(s), show contact's name, address, phone number **and e-mail address**, for the specialty event in the monthly issue preceding the month of the specialty event and/or on the ApHC website **and/or by electronic communication to ApHC members. The ApHC shall publish the class list for the specialty event including any additions to the list of classes in the application on the ApHC web site at least 30 days prior to the show. Classes in the premium list or published on the ApHC web site must be held if there is an entry.** Changes in a specialty event application, **including additions to the list of classes**, may not be made **within 30 days prior to the first day of the specialty event.**
- f. For a specialty event to meet minimum requirements and have the results recorded, there must be a minimum of three Appaloosas entered that are registered with the ApHC and eligible to show.
- g. Show management must collect \$2 per entry per judge in nationally pointed open classes and \$1 per entry per judge in nationally pointed youth and non-pro classes and forward to the ApHC in order for show results to be processed.
- h. The results of any specialty event must be completed in their entirety on official forms furnished or approved by the ApHC. These forms must list the first eight horses in each class unless fewer than that number competed. These results must be forwarded by certified mail, return receipt or other guaranteed receipted mail service to the ApHC and must be postmarked within 10 calendar days of the last day of the show. Computer forms will be accepted as long as prior approval is granted. A printed show bill must accompany the results.
- i. All specialty events must be reported regardless of number of entries. If a specialty event is canceled, this must also be reported.
- j. Failure to comply with ApHC rules, regulations, and policies or failure to mail the completed result forms to the ApHC postmarked within 10 days of the last show date shall result in the show being cited for a violation of these rules, the punishment for which may include censure, and/or a fine. If the fine is not paid, it will be added to the application fee for the next show. Future show dates will not be approved until the penalty is paid.
- k. Show management must notify the ApHC Show Department in writing of any amendments or corrections to show results. Corrections cannot be made to show results after December 21 for shows held prior to November 15. For shows held after November 15, corrections must be in the ApHC office by December 31 of the current show year.
- l. Following is a list of classes approved to be held at any specialty event:
 - 1. Games: Camas Prairie Stump Race, Nez Perce Stake Race, Key-hole Race, Figure 8 Stake Race, Rope Race.
 - 2. Cattle: Judged Tie-Down Roping, Timed Tie-Down Roping, Judged Heading, Judged Heeling, Heading & Heeling, Breakaway Roping, Steer Daubing, Cutting, Working Cow Horse, Hackamore/Snaffle Bit Working Cow Horse (optional, non-pointed class)
 - 3. Over Fences: Jumping, Preliminary Jumping, Working Hunter, Green Hunter, Pre-Green Hunter, Equitation Over Fences, Hunter Hack
 - 4. Reining, Hackamore/Snaffle Bit Reining

Contact the ApHC office for a specialty event approval application.

U. All major livestock shows and state fairs that meet eligibility requirements as determined solely by the ApHC based upon the size, scope and marketing potential of the show or fair, will be allowed one double-judged, double-pointed show per year, which is defined as an eligible livestock show or state fair at which a maximum of two judges judge independently of each other at one show judging either concurrently or on different days; therefore requiring a show approval application listing both judges and requiring two separate sets of show results and two sets of judge's cards and at which exhibitors will receive two sets of points for each judge's placings. Each class may only be conducted once per each judge and each judge may only turn in one set of judge's cards for that show.

1. Show management shall collect point fees according to rule 601.T.2.g and shall not collect double fees nor submit double fees to the ApHC.
2. Show management shall pay the standard show approval fee of \$25/judge for members or \$50/judge for non-members. Shows that meet eligibility requirements shall not be required to pay double the approval fees.

V. Any show sponsor in an emerging international market may submit a specialty show application. Approval for these shows will be granted on a show-by-show basis as determined by the Appaloosa Horse Club. If approved, the minimum number of required classes will be waived.

W. Single-judge, Fee-waiver Shows

1. Show organizers may host one or more one-judge show per year for which national point fees shall be waived.
 - a. Existing shows are not eligible for this fee waiver unless they conform to this format.
 - b. If a Regional Club must reschedule a single-judge show due to an act of God, such single-judge show may be combined with another previously-scheduled single-judge show approved under the fee-waiver provision. In such case both shows shall retain their fee-waiver status. All other show approval requirements shall continue to apply.
2. For fee-waiver shows sponsored or co-sponsored by a regional club, the approval fee is \$25.
3. The approval fee is \$50 for shows that are not sponsored or co-sponsored by a regional club.
 - a. Shows must be sponsored by a current ApHC member.
4. Shows must be combined with open, all-breed classes and said classes must be intermixed with regular ApHC-approved classes.
 - a. A class schedule for the event must be submitted to ApHC along with the approval application and must list the classes in scheduled order.
 - b. In single judge fee-waiver shows held by a Regional Club or International Affiliate/Partner and ApHC-approved under this section, non-Appaloosa horses may compete in the same class with ApHC registered horses as stipulated in the show premium if show management deems this practice to be beneficial for the show's success. Only ApHC horses are to be reported to the ApHC when show results are submitted to the ApHC at the conclusion of the show and shall be listed 1st through 8th in the order placed at the conclusion of the class regardless of where the ApHC horses placed within the all-breed horses included in the class—"ApHC Class Placings" will be documented from highest to lowest with highest to be first and so on until the top 8 Appaloosa horse entries have been placed according to ApHC Show rules. Further, only ApHC-registered horses that are eligible to be shown according to current rules shall be included in the number of entries in each class.
5. It is intended that these shows offer a low-cost introduction to ApHC-approved events for new or novice exhibitors and that they be used to expose the general (all-breed, open show) horse public to Appaloosa horses. Show organizers must provide information regarding the marketing/promotional efforts undertaken in an effort to satisfy this intent.
6. There are to be a limited selection of basic classes at these shows. However, show organizers may choose a class list that best reflects needs in their geographical area. Minimum class requirements as contained in rules 603 and 604 apply to single-judge, fee-waiver shows.

7. These shows shall not be held in conjunction with another ApHC-approved show and shall not be held at the same facility within 5 days of another ApHC-approved show.

8. All other show approval rules per rule 601.A-S apply to single-judge, fee-waiver shows.

602. MULTI-JUDGE SHOWS

- A. A multi-judge show is an event with more than one horse show (one judge) but not more than four horse shows (four judges), which are conducted simultaneously.
- B. To obtain show approval, an application form supplied by the ApHC must be submitted and accompanied by a non-refundable application fee.
- C. An exhibitor must show to all judges in the applicable class in the multi-judge show, other than as provided in Rule 500.P(5). The national point fee in order to have show results processed for a multi-judge show is \$2 per entry per judge in nationally pointed open classes and \$1 per entry per judge in nationally pointed youth and non-pro classes.
- D. Class fees charged for multi-judge shows shall be no more than the normal fee charged for single judge shows multiplied by the number of judges in the applicable class in the multi-judge show.
- E. One cattle fee shall be charged for each run in a multi-judge show.
- F. Each class in a multi-judge show will be judged concurrently. However, in timed gaming and cattle events, a maximum of one run per every two judges is allowed at show management's sole discretion.
- G. The results of the Grand and Reserve Champion classes will not be announced until all judges for that day have completed their judging of the respective sex divisions of the Grand and Reserve Champion classes.
- H. Multi-judge show regulations will also apply to youth shows, the youth section of shows, non-pro shows and the non-pro section of shows.
- I. No more than four single judge shows or any combination of multi-judge shows, not to exceed four judges, may be held during a period of seven consecutive days at the same facility and/or grounds unless there are a minimum of four days off between the first held shows and/or events and the latter held shows and/or events, and the latter held shows and/or events commence no earlier than seven days after the commencement of the first held shows and/or events.

J. CIRCUIT SHOWS

1. Exceptions to Rule 602.I.

- a. Circuit shows and/or events may be held at the same facility within a consecutive period of seven and nine days.
- b. Circuit shows and/or events shall not exceed eight sets of points.
- c. Shows and/or events shall not exceed three judges simultaneously at any one time.
- d. There must be at least one day off after all multi-judged shows.
- e. There must be one day off before any multi-judged shows and/or events start (i.e. a single-judged show to a multi-judged show).
- f. No shows and/or events shall be held seven days prior to or after said circuit shows and/or events at the same facility.
- g. Circuit shows and/or events must be sponsored by an ApHC-affiliated regional club and any such regional club shall not sponsor more than one (1) circuit show and/or event during any calendar year.

603. MINIMUM CLASS REQUIREMENTS FOR SHOW APPROVAL

For a show to be approved, the following classes must be offered:

- A. Four halter classes for stallions:
 1. Yearlings
 2. Two-Year-Olds
 3. Three-Year-Olds
 4. Four-Year-Olds and Older

- B. Four halter classes for mares:
 1. Yearlings
 2. Two-Year-Olds
 3. Three-Year-Olds
 4. Four-Year-Olds and Older
- C. Four halter classes for geldings:
 1. Yearlings
 2. Two-Year-Olds
 3. Three-Year-Olds
 4. Four-Year-Olds and Older
- D. Grand and Reserve for each sex division. It is mandatory that all approved shows select Grand and Reserve Champions in each sex division.
- E. Four performance classes selected from the following list of classes:
 - Hackamore/Snaffle Bit Reining
 - Junior Reining
 - Senior Reining
 - Junior Western Riding
 - Senior Western Riding
 - Two-Year-Old Snaffle Bit Western Pleasure
(only for shows held after May 20)
 - Three-Year-Old Snaffle Bit Western Pleasure
 - Junior Western Pleasure
 - Senior Western Pleasure
 - Two-Year-Old Snaffle Bit Hunter Under Saddle
(only for shows held after May 20)
 - Three-Year-Old Snaffle Bit Hunter Under Saddle
 - Junior Hunter Under Saddle
 - Senior Hunter Under Saddle
 - Junior Hunter Hack
 - Senior Hunter Hack
 - Junior Saddle Seat Pleasure
 - Senior Saddle Seat Pleasure
 - Ladies' Side Saddle
 - Pleasure Driving
 - Junior Trail
 - Senior Trail
 - Preliminary Jumping
 - Jumping
 - Pre-Green Hunter
 - Green Hunter
 - Working Hunter
 - Junior Working Cow Horse
 - Senior Working Cow Horse
 - Junior Cutting
 - Senior Cutting
 - Junior Judged Tie-Down Roping
 - Senior Judged Tie-Down Roping
 - Junior Timed Tie-Down Roping
 - Senior Timed Tie-Down Roping
 - Junior Judged Heading
 - Senior Judged Heading
 - Junior Judged Heeling
 - Senior Judged Heeling
 - Junior Timed Heading and Heeling
 - Senior Timed Heading and Heeling
 - Steer Daubing
 - Figure 8 Stake Race
 - Keyhole Race

- Camas Prairie Stump Race
- Nez Perce Stake Race
- Rope Race
- Men's Heritage
- Ladies' Heritage
- Yearling Longe Line
(only for shows held after May 20)

- F. Optional pointed halter classes:
 - Broodmares
 - Weanling Colts (only for shows held after May 20)
 - Weanling Fillies (only for shows held after May 20)
 - Weanling Geldings (only for shows held after May 20)
 - Hunter in Hand, Stallions
 - Hunter in Hand, Mares
 - Hunter in Hand, Geldings
 - Most Colorful at Halter
 - FPD Stallions
 - FPD Mares
 - FPD Geldings
- G. Shows may also offer these optional non-pointed classes:
 - Get of Sire
 - Produce of Dam
 - Buckboard Driving
 - Men's Western Pleasure
 - Ladies' Western Pleasure
 - Team Penning
 - Hackamore/Snaffle Bit Working Cow Horse
- H. Classes listed as junior and senior **may be combined** at the direction of the judge or show management with the unanimous consent of all exhibitors involved in the class (or classes) in question. **Youth age divisions may be combined or 18 & under classes may be split at the direction of the judge or show management with the unanimous consent of all exhibitors involved in the class or classes in question.** Entries will be accepted after a class is combined.
- I. Pre-Green Hunter may not be combined with Green Hunter.

604. YOUTH AND NON-PRO SHOW APPROVAL

- A. In order for any youth class, youth division, youth show, non-pro class, non-pro division or non-pro show to be approved by the ApHC, the rules and regulations in the current ApHC Handbook must be followed.
- B. No youth and/or non-pro show, division or classes shall be advertised as being approved by the ApHC until all of the above conditions are met in their entirety and written permission has been granted from the ApHC.
- C. A non-pro or youth cannot be required to enter an open class to qualify for high point awards.
- D. All approved youth classes must be open to youth who meet age and horse ownership requirements, unless additional ApHC restrictions apply. (See leadline, walk-trot and novice rules).
- E. For all youth classes, the following are mandatory age divisions: Leadline - 6 years and under; Walk-Trot - 10 years and under. If a show wishes to offer a class in one division, it must be held as 18 years and under; two divisions must be held as 13 and under and 14 through 18; or three divisions must be held as 12 and under, 13 through 15 and 16 through 18. A show may not offer more than three divisions in any one youth class.
- F. For youth show approval, at least six approved youth performance events must be offered. One Showmanship at Halter and one horsemanship/equitation class are mandatory. Showmanship at Halter may be held as one (18 & under) or two (13 & under, 14-18) or three (12 & under, 13-15, 16-18) age divisions. Youth age divisions may be combined or 18 & under classes may be split at the

direction of the judge or show management with the unanimous consent of all exhibitors involved in the class (or classes) in question. Two novice youth classes must be offered in addition to the above stated. Age divisions for novice youth are 18 & under, or 13 & under and 14-18.

G. All approved non-pro classes must be open to non-pros who meet age, eligibility, horse ownership and membership requirements, unless additional APHC restrictions apply. (See novice, 35 & over and masters non-pro rules).

H. For non-pro show approval, four non-pro classes must be offered; two English and two western.

1. For each novice non-pro class held at the show, the corresponding non-pro class must also be held.

I. Following are the youth events approved for national points:

Western Showmanship at Halter
English Showmanship at Halter
Western Horsemanship
Hunt Seat Equitation
Hunt Seat Equitation Over Fences
Saddle Seat Equitation
Bareback Horsemanship
Leadline
Trail
Western Pleasure
Western Riding
Hunter Under Saddle
Saddle Seat Pleasure
Hunter Hack
Working Hunter
Heritage
Reining
Breakaway Roping
Judged Tie-Down Roping
Judged Heading
Judged Heeling
Cutting
Steer Daubing
Camas Prairie Stump Race
Nez Perce Stake Race
Keyhole Race
Figure 8 Stake Race
Walk-Trot Western Horsemanship
Walk-Trot Hunt Seat Equitation
Walk-Trot Keyhole Race
Walk-Trot Nez Perce Stake Race
Walk-Trot Camas Prairie Stump Race
Walk-Trot Figure 8 Stake Race
Walk-Trot Western Pleasure
Walk-Trot Hunter Under Saddle
Walk-Trot Trail
Walk-Trot Showmanship
Jumping
Halter Mares
Halter Geldings
Most Colorful at Halter
Hunter in Hand, Mares
Hunter in Hand, Geldings
Novice Showmanship

Novice Western Horsemanship

Novice Hunt Seat Equitation

Novice Western Pleasure

Novice Hunter Under Saddle

Optional non-pointed classes:

Team Penning

J. Following are the non-pro events approved for national points. Letters listed behind each class indicate the divisions available for each class. These letters are: NP = Non-Pro; 35 = 35 & Over Non-Pro; MS = Masters Non-Pro; NV = Novice Non-Pro; WT=Walk/Trot.

1. The class list is broken into Western, English and Other divisions.

Western Classes

Showmanship at Halter (NP, 35, MS, NV)
Bareback Horsemanship (NP, NV)
Western Horsemanship (NP, 35, MS, NV, W/T)
Western Pleasure (NP, 35, MS, NV, W/T)
Trail (NP, MS, NV, W/T)
Western Riding (NP, MS, NV)
Reining (NP, MS, NV)
Cutting (NP, NV)
Judged Tie-Down Roping (NP, NV)
Judged Heading (NP, NV)
Judged Heeling (NP, NV)
Steer Daubing (NP, NV)
Working Cow Horse (NP, NV)
Breakaway Roping (NP, NV)
Timed Tie-Down Roping (NP, NV)
Timed Heading and Heeling (NP, NV)

English Classes

Working Hunter (NP, NV)
Jumping (NP, NV)
Hunter Hack (NP, NV)
Hunt Seat Equitation (NP, 35, MS, NV, W/T)
Hunt Seat Equitation Over Fences (NP, NV)
Hunter Under Saddle (NP, 35, MS, NV, W/T)
Saddle Seat Pleasure (NP, NV)
Saddle Seat Equitation (NP, NV)
Pleasure Driving (NP, NV)

Other Classes

Nez Perce Stake Race (NP, NV, W/T)
Camas Prairie Stump Race (NP, NV, W/T)
Keyhole Race (NP, NV, W/T)
Figure 8 Stake Race (NP, NV)
Halter Mares (NP)
Halter Geldings (NP)
Halter Stallions (NP)
Hunter in Hand, Stallions (NP)
Hunter in Hand, Mares (NP)
Hunter in Hand, Geldings (NP)
Most Colorful at Halter (NP)
Yearling Longe Line

Optional non-pointed classes:

- Team Penning
- Western Riding (35)
- Trail (35)

605. SHOW RESULTS

- A. For a show to meet minimum requirements and have the results recorded, there must be a minimum of 24 Appaloosas that are registered with the ApHC and eligible to show, except that an ApHC Regional Club-sponsored show shall have no minimum horse requirement. They must be judged by an approved ApHC judge in approved ApHC classes at the show. All shows held outside of the USA shall be exempt from the 24-horse requirement.
- B. The results of any ApHC-approved show or contest must be completed in their entirety on official forms furnished or approved by the ApHC. These forms must list the first eight horses unless fewer than that number competed. These results must be forwarded by certified mail, return receipt or other guaranteed receipted mail service to the ApHC and must be postmarked within 10 calendar days of the last show date. Computer forms will be accepted as long as prior approval is given. A printed show bill must accompany the results.
- C. All shows must be reported regardless of the number of entries. If a show is canceled, this must also be reported.
- D. Failure to comply with ApHC rules, regulations, and policies or failure to mail the completed result forms to the ApHC postmarked within 10 days of the last show date shall result in the show being cited for a violation of these rules, the punishment for which may include censure, and/or a fine. If the fine is not paid, it will be added to the application fee for the next show. Future show dates will not be approved until the penalty is paid.
- E. Show management must notify the ApHC Show Department in writing of any amendments or corrections to show results. Corrections cannot be made to show results after December 21 for shows held prior to November 15th. For shows held after November 15, corrections must be in the ApHC office by December 31 of the current show year.
- F. Show management must collect \$2 per entry per judge in nationally pointed open classes and \$1 per entry per judge in nationally pointed youth and non-pro classes and forward to the ApHC in order for show results to be processed.

606. SHOW MANAGEMENT GENERAL RULES

A. SAFETY

1. The management is requested to give detailed consideration to all safety precautions for a youth show or classes. Particular attention should be given to classes where very young exhibitors are competing. The safety and well-being of youth competitors is a serious responsibility of the show management.
 - a. It is suggested that the show management designate two adults (other than the judge and ring steward) to be in the arena during Walk-Trot classes to help any exhibitor who might need assistance. The two adults should be stationed so as to avoid disrupting the classes.
2. Judges and ring stewards should follow class procedures that make certain there is sufficient space for the exhibitor to move into any position requested by the judge or ring officials. Particular caution should be given to the distance between the class line-up and the arena fence.
3. Except in the holding area for cutting classes, horses should not be tied to arena fences or rails or any other place that would constitute a hazard.

B. RING STEWARDS

1. See RULES FOR RING STEWARDS.

C. JUDGES

1. No judge shall be required to judge longer than six (6) hours in any one day without a reasonable break of at least one-half hour. Shows which fail to comply will be fined for each hour of violation and/or otherwise disciplined.

2. The show management shall send to the ApHC a report on the performance of the judge. The individual or individuals completing this form shall indicate if they owned or exhibited any horses in this show or contest. Forms for this report will be supplied by the ApHC.
3. In the event that any judge at or during any show is guilty of gross misconduct or engages in belligerent or extremely disruptive behavior or is in such a physical, mental, or emotional condition so as to substantially affect such judge's ability to judge properly, show management, in its sole discretion, shall have the right to prohibit such judge from judging the show and to remove such judge from the show grounds. The show management shall, on the next business day, file a written report of any such incident to the ApHC.
4. In cases of emergency, a guest judge may serve with the approval of the President or Chief Executive Officer of the ApHC. If said emergency takes place over a holiday or weekend when such approval cannot be obtained, the show will immediately report to the ApHC by certified mail, a full description of the circumstances requiring the hiring of such guest judge together with the guest judge's name and qualifications. The Chief Executive Officer will approve or disapprove the use of such individual. Disapproval of the guest judge will cancel the show's approval for National points.

D. ANNOUNCER

1. At ApHC-approved shows, show management shall not announce the names of horses, owners and/or exhibitors prior to the completion of judging of a class. All entries shall be referred to by back number. All class results must be announced by judge name. At ApHC-sponsored events, under the direction of show management, the announcer may announce the names of horses and/or exhibitors during the course of the class.
2. At all approved shows, results should be announced for each judge before the next class starts. Announcements shall include, at a minimum, the name of the exhibitor and back number of the horse.

E. PREMIUM LIST / PRIZES

1. Entry fees must be included on the premium list and shall be published by the ApHC in *Appaloosa Journal* and/or the ApHC web site and/or by electronic communication to ApHC members. No changes to entry fees can be made after such publication.
2. If money prizes are offered, the fixed amount of added moneys shall be stated in the premium list. Special prizes do not have to appear on the premium list but is recommended. The management cannot require a portion of the premium money to be added to any championship class.
3. The premium list shall contain a list of officials of the show and the exact location, time and date or dates to be held along with the closing date of entries. The height of fences in over fence classes must also be listed.
4. The awarding of money prizes or purses is strictly forbidden in exhibitor-judged youth or non-pro classes in an approved show. Exhibitor-judged classes include all equitation, horsemanship and showmanship classes, including western showmanship, english showmanship, hunt seat equitation, hunt seat equitation over fences, bareback equitation, saddle seat equitation, western horsemanship, leadline, walk-trot equitation and walk-trot horsemanship. Money prizes or purses are allowed in horse-judged classes, which include pleasure classes, cutting, games classes, jumping, working hunter, roping classes, working cow horse, reining, western riding, trail and hunter hack.
5. A non-pro or youth cannot be required to enter an open class to qualify for high point awards.

F. CANCELLATION OF SHOW OR CLASS

1. Sponsors of shows who cancel their show dates must notify the ApHC Show Department immediately so that date can be made available to another sponsor.
2. Show management cannot cancel a class unless so stated in the premium list; however, classes in premium list or published by the ApHC in *Appaloosa Journal* and/or the ApHC web site and/or by electronic communication to ApHC members must be held if there is an entry.

G. CLASS SCHEDULE

1. An approved show will not be permitted to start earlier than the time printed in the premium list, the advertised schedule, or published by the ApHC in *Appaloosa Journal* and/or the ApHC web site and/or by electronic communication to ApHC members.
2. Classes in the premium list or printed in *Appaloosa Journal* must be held if there is an entry.
3. Classes scheduled for one day of a multiple-day approved show will not be rescheduled to an earlier day once the premium list and advertised schedule is published and distributed. If the order of classes in the time schedule on a given day, or classes scheduled for one day of a multiple-day approved show must be rescheduled to a later day, all affected exhibitors must be notified, and a report of the change must be submitted to the Show Department, which shall review the report for compliance with the rules and adequate notice to exhibitors. Should the Show Department find the change was not in compliance, the affected classes will lose their approval and/or the show will be fined. If any such changes are due to emergency, and/or acts of God, and as such, not in compliance with the rule, show management must send a complete report to the Show Department, which shall review it and decide whether or not such change was warranted.

H. VERIFICATION OF ENTRIES

1. Owner, exhibitor, youth and non-pro membership cards must be checked before issuing exhibitor's numbers and/or before the horse enters the arena or ring. Failure to do so may result in automatic cancellation of the show's approval.
2. Show management must inspect the Certificate of Registration (if photocopies are used, they must be of both sides of the Certificate) of each horse entered in all approved, optional, youth and non-pro classes. Entries shall be made in the name of the current recorded owner or owners as indicated by records in the ApHC office and on the Certificate of Registration at the time the horse is shown.
3. Show Management must verify the relationship of the youth exhibitor to one owner of the horse(s) being used in youth events. See YOUTH RULES.
4. Show management must verify the relationship of the non-pro exhibitor to all owner(s) of the horse(s) being used in non-pro events. See NON-PRO PROGRAM ENROLLMENT AND PARTICIPATION RULES.

I. DRUG TESTING

1. At an ApHC-approved event, only representatives of event management acting pursuant to ApHC rules, or the ApHC may request specimens of urine, saliva, blood, or other substances for testing for the presence of forbidden substances or require payment of testing fees as a condition of entry. Testing fees charged by an approved event are subject to prior approval by the ApHC.

J. VIOLATIONS.

An ApHC-approved show is subject to penalty by the Executive Committee or the Chief Executive Officer for violation of rules. Violations include, but are not limited to, the following:

1. Failure to conduct the show in accordance with ApHC rules.
2. Failure to mail completed result forms to the ApHC postmarked within 10 days of the last show date.
3. Failure to pay its indebtedness to the ApHC.
4. Failure to pay premiums and other indebtedness within 60 days.
5. Failure to report the disqualification of a person at the show (excluding disqualification in a class for improper or prohibited equipment or for an off-course or 0 score run).
6. Failure to honor written contracts with judges or other show officials and employees.
7. Failure to furnish the ApHC with entry blanks, judge's cards, class sheets or any other documents it may request in connection with the show.

8. The use of regular or specialty judges not approved by the ApHC.
9. The listing of a judge in the show bill before the invitation to serve has been accepted.
10. Permitting persons or horses adjudged not in good standing to participate in any manner.
11. Permitting acts which are improper, intemperate, dishonest, unsportsmanlike or contrary to the rules of the ApHC.
12. Acting in a manner prejudicial to the best interests of the ApHC.

K. PENALTIES

An ApHC-approved show found guilty of a violation will be subject to penalty including but not limited to the following:

1. Fines: the minimum fine per show or judge will be \$25.00 and the maximum fine per show or judge will be \$100.00.
2. Censure which will be listed under the names of the show, show manager and show secretary in the Show Department Record of Penalties.
3. Suspension for any period from the list of approved ApHC shows.
4. Suspension of the regional club charter for any period.
5. Expulsion from membership in the ApHC.
6. Revocation of the regional club charter.

L. PATTERNS

1. In all classes where a pattern is used, it must be posted at least 1 hour prior to the class.
2. If a show prepares patterns, the judge(s) must approve use of such patterns.

607. ELIGIBILITY TO SHOW

- A. In ApHC-approved shows, only horses, including current year foals, that are ApHC-registered with Regular (#) or CPO (CN) registration classification, or have been issued a Performance Permit prior to the show are eligible to participate. Horses registered in any other Appaloosa registry either in the United States or in any other country are not eligible to show in any approved show, unless also registered with the ApHC. The exhibitor must be able to prove that the horse is properly registered with the ApHC and eligible to show under ApHC rules. Show management must inspect the Certificate of Registration (if photocopies are used, they must be of both sides of the certificate) of each horse entered in all approved, optional, youth and non-pro classes. Entries shall be made in the name of the current recorded owner or owners as indicated by records in the ApHC office and on the Certificate of Registration presented.
- B. No horse is eligible to participate in an ApHC-approved show, including horses aiding or assisting in any part of the show, (except as noted in B.1 below), unless the horse is registered with the ApHC.
 1. In ApHC-approved cutting events, non-ApHC registered horses may be used in the arena as turn back and herd holding horses. At ApHC-sponsored shows, all horses in the arena must be registered with the ApHC.
- C. No ApHC-registered horse carrying Regular (#) or CPO (CN) registration classification, or having been issued a Performance Permit prior to the show can be denied the right to participate in any approved race, show or contest, if otherwise eligible. The ApHC will not approve any such races, shows or contests.
- D. All persons participating or competing in ApHC-approved or-sponsored shows must be active members in good standing of the ApHC. Persons participating or competing shall be defined to include owners, trainers and exhibitors, except riders of horses used solely to assist cutting horses. In the event an exhibitor cannot produce a current ApHC membership card or proof of payment, he/she will be allowed to show upon payment of a new membership fee which will be refunded by the ApHC, less a \$5 non-refundable handling fee, upon establishment of a current membership.

1. Active AYA members may comply with the membership requirement as a part of a family membership, or with a youth affiliation membership. All youth exhibitors must be AYA members.
 2. Non-Pro exhibitors must be ApHC members and be enrolled in the Non-Pro program.
- E. State Funded Shows - Show management shall be allowed qualification of monetary assistance from the state in which an ApHC approved show or event is conducted, where the state prohibits exclusion of non-members. If otherwise qualified, a non-member may gain entry in the open, non-pro and youth divisions of ApHC shows by payment of non-member fee equal to the amount specified in the fee schedule for annual membership dues and for non-pro entrants, payment of the additional non-pro enrollment fee. Payment of this fee will allow a non-member access to the particular event of show, which includes the entire show circuit. By entering as a non-member, the individual agrees to abide by all ApHC rules, including but not limited to show rules, failure of which may result in permanent exclusion from ApHC approved or sponsored events, after prior notice and hearing before the ApHC Disciplinary Committee, pursuant to ApHC rules pertaining to disciplinary proceedings. Upon collection, all such fees must be remitted to the ApHC by show management.
- F. No exhibitor can be required to be a member of any club or association other than the ApHC in order to compete in any approved class or show.
- G. A totally blind horse is not eligible to show in any class. A horse with one eye is eligible to compete; however, exhibitors are urged to use caution when choosing to exhibit a horse with a sight impairment, exercising caution at all times when considering the limitations of the horse, the safety of the exhibitor and the safety of other exhibitors in the class.
- H. Horses entered in all events must be serviceably sound and in good condition. Small blemishes on account of accident, for example, wire cuts and brands, are not to be counted against the horse.
- I. Only junior horses may be entered in a junior or hackamore/snaffle bit classes. Junior horses are FIVE years old and younger.
- J. Only senior horses may be entered in senior classes. Senior horses are SIX years old and older.
- K. To maintain eligibility the two-year-old year for two-year-old events, entry into other performance events is prohibited with the following exceptions: Two-year-olds may cross enter two-year-old snaffle bit hunter under saddle, two-year-old western pleasure, pleasure driving, men's heritage, ladies' heritage, 1st year green pleasure classes and snaffle bit/bosal futurities. A two-year-old may cross-enter junior western pleasure and/or junior hunter under saddle after May 20 only if there are no other entries in their respective two-year-old class and only if the two-year-old class precedes the junior class(es) on the class list.
1. In order to maintain two-year-old eligibility, horses may only be shown in equipment acceptable for use in two-year-old classes regardless of which class in which they are exhibited.
 2. Once a horse has been shown in anything other than an acceptable snaffle bit or bosal, it is no longer eligible to be shown in snaffle bit/hackamore classes.
 3. When there is no intention for a junior horse to remain snaffle bit class eligible, that horse may be shown in a snaffle bit, hackamore or curb bit as the same show. Once this occurs, the horse is expressly denied the right to compete in snaffle bit/hackamore classes.
 4. Two-year-old performance classes may not be held prior to May 20. Two year olds may not be shown in any ApHC-approved performance event prior to May 20 of the current year.
- L. Performance classes are open to stallions, mares and geldings with the exception that youth may not ride a stallion in classes designated as youth or junior exhibitor 18 years of age and under. Stallions may be shown by anyone in all classes in other divisions.

608. ENTRIES

- A. All entries must be made on official entry blanks and must be signed by the responsible parties. Exhibitors are responsible for any errors on the entry blanks. No entry will be accepted where an exhibitor prescribes the conditions under which he will exhibit. Parent or legal guardian must sign for an exhibitor under 18.
- B. Presentation of signed entry blanks shall be deemed acceptance of all rules, and in the event of failure to sign the entry blank, the first entry into the show ring as an exhibitor shall be deemed to be an acceptance of said rules.
- C. Management reserves the right to decline any entry for cause and to return the entry before or during the show without being liable for compensation. Written reasons for declining entry by show management under this rule must be presented to the person whose entry is declined. The show management shall as soon as possible forward a copy of the reasons to the ApHC. "Cause" is defined to include, but not be limited to:
 1. Exhibiting unsportsmanlike conduct.
 2. Cruel and inhumane treatment.
 3. Committing any act which is prejudicial to the best interests of the ApHC or conduct detrimental to the legitimate business interests of the ApHC.
 4. Engaging in abusive, intimidating, or threatening behavior toward any judge, director, officer, staff member, employee of the ApHC or any show personnel while in furtherance of their official duties.
 5. NSF checks whereby funds are not secured prior to the show.
- D. Classes in the premium list or published by the ApHC in *Appaloosa Journal* and/or the ApHC web site and/or by electronic communication to ApHC members must be held if there is an entry.
- E. No approved ApHC show may require that an exhibitor must enter or pay entry fees for a horse in a halter class in order for that horse to be eligible to compete in a performance class, nor may the management require a horse to be entered in a performance class in order that it may show in halter. Such entries shall be optional to the exhibitor.
- F. No open ApHC pointed class can exclude the entry of a youth exhibitor 18 years and under.
- G. A non-pro or youth cannot be required to enter an open class to qualify for high point awards.
- H. Classes listed as junior and senior **may be combined** at the direction of the judge or show management with the unanimous consent of all exhibitors involved in the class (or classes) in question. **Youth age divisions may be combined or 18 & under classes may be split at the direction of the judge or show management with the unanimous consent of all exhibitors involved in the class or classes in question.** Entries will be accepted after a class is combined.
 - I. Show management shall not accept additional entries in a class once competition or judging for the previous class has begun.
 - J. In individual working events; reining, working cow horse, western riding, camas prairie stump race, (where class is timed only), Nez Perce stake race, (where class is timed only), jumping, working hunter, trail, judged heading, judged heeling, breakaway roping, judged tie-down roping, timed tie-down roping, timed heading and heeling, hunter in hand, steer daubing, keyhole race, figure 8 stake race and cutting, an exhibitor may enter and show one or more horses in a class but each horse may have only one exhibitor/handler per class.
 1. Non-Pros can only ride one horse in Non-Pro Camas Prairie Stump Race and Non-Pro Nez Perce Stake Race **except that a non-pro exhibitor may ride a maximum of two horses in these two classes provided they are timed-only classes.** Non-Pro exhibitors may ride a maximum of two horses in the walk-trot divisions of these two classes as they are time-only classes.
 2. Youth exhibitors (including walk-trot exhibitors) may ride a maximum of 2 horses in each of the classes listed above (provided they are currently offered to youth exhibitors as approved classes). Youth exhibitors may only ride one horse in youth Nez Perce stake race and youth camas prairie stump race

except that a youth exhibitor may ride a maximum of two horses in these two classes provided they are timed-only classes. Walk-trot exhibitors may ride a maximum of two horses in walk-trot Nez Perce stake race and walk-trot camas prairie stump race as they are time-only classes.

K. An exhibitor with special needs, which term is defined for purposes of this rule as a permanent disability, may apply for a variance from the ApHC Chief Executive Officer, to accommodate their special needs to allow them to show in and be judged in classes they seek to enter. Any variance application may be granted or denied at the sole and absolute discretion of the ApHC Chief Executive Officer who may impose any conditions on any variance approval that are deemed advisable. If any variance application is so granted, the ApHC Chief Executive Officer will issue a letter to the special-needs exhibitor granting the variance and stating any applicable accommodations, conditions and classes allowed. The original letter so issued must be shown by such special-needs exhibitor to show management before the special-needs exhibitor will be permitted to show. This variance must be applied for each calendar year, will expire on December 31 of each year and can be revoked at the discretion of the ApHC Chief Executive Officer at any time.

609. SHOW VIOLATIONS

A. To promote competition in ApHC-approved events, in order that the ApHC records will, at all times, reflect the actual quality of equine performance, any form of conduct which inhibits competition is expressly prohibited and must be immediately reported to the ApHC. This offense includes not only the person suggesting the prohibited conduct, but all who participate in the scheme or plan. Violation of any show rule set forth shall result in disqualification from participation of the horse and/or exhibitor, forfeiture of the entry fee and referral of the matter to the ApHC for disciplinary action. Such conduct includes, but is not limited to any person:

1. Exhibiting unsportsmanlike conduct. Any such unsportsmanlike conduct shall jeopardize their right to further exhibit in the show. At any time, the judge and/or Show Committee may issue a first warning to any exhibitor and/or owner for unsportsmanlike conduct. Upon failure to comply with this warning, the judge or show management will disqualify the exhibitor from further classes for the remainder of the show.
2. Padding the classes by entering a horse(s) not otherwise qualified for the competition, to fill a class to increase show points; paying another's entry fees, directly or indirectly, or; encouraging a potential competitor to refrain from entering a class. The same disqualification and disciplinary action shall also apply to all individuals who attempt to keep a potential competitor from entering a class. To assist the ApHC in the promotion of true competition, any person who is approached by another to cooperate in a scheme or plan to inhibit competition, shall immediately report the matter to the ApHC, failing which, the person approached may be subject to disciplinary action by the Executive Committee, the same as the person or persons suggesting the scheme or plan.
3. Treating horses inhumanely or cruelly, the discovery of which by a show official shall be reported to show management and show management may immediately disqualify the horse and report the same to the ApHC for disciplinary proceedings.
4. Committing any act which is prejudicial to the best interest of the ApHC, including but not limited to acting or inciting or permitting any other to act in a manner contrary to the rules of the ApHC, or in a manner deemed improper, unethical, dishonest, unsportsmanlike or intemperate, or prejudicial to the best interests of the ApHC.
5. Exhibiting a horse before a judge who has, within the previous **90** days, received a salary, commission or any kind of remuneration for selling, buying, training or fitting any horse for that owner, exhibitor or agent of that owner or exhibitor.
6. Engaging in abusive, intimidating or threatening conduct toward an ApHC Judge; engage in any conduct toward an ApHC judge intending to cast aspersions on the character or integrity of the judging; or inspect a judge's place card without the judges permission.

7. Committing any act or make any remark in connection with the show or contest that may be considered offensive.
8. Attempting to substitute a horse without declaring the substitution and displaying proper registration when entering an ApHC-approved or -sponsored event.
9. Assaulting or battering another person during an ApHC-sponsored or approved event.
10. Exhibiting any horse while in the care, training or custody of a suspended trainer for the benefit, credit, reputation or satisfaction of the suspended trainer.
11. Riding, exhibiting, coaching or training at an ApHC-approved or -sponsored event for the benefit, credit, reputation or satisfaction of a suspended person.
12. Contacting or attempting to contact a judge after the judge has accepted a judging assignment pertaining to judging of any horses at that show. Further, exhibitors shall not approach judges for any reason prior to the completion of judging unless the ring steward is present. Any request to speak to the judge must be made through the ring steward or another show official and any conversation with the judge shall take place in the presence of the ring steward or other show official. No exhibitor shall socialize, fraternize or visit with a judge the day prior to or the day of the show.

610. SHOW PROTEST AT APHC-APPROVED SHOW

- A. A protest relating to conduct at an ApHC-approved show for any violation of ApHC or show rules may be made by a current member in good standing of the ApHC who is also an exhibitor and/or parent of a youth exhibitor at that show. Such person making the protest shall deliver it in writing with the show secretary or show manager within 12 hours of the time of the alleged violation. The protest must specify the rule allegedly violated. No protest shall be valid unless accompanied by a deposit of \$250.00 by cash or check, delivered to the organization sponsoring the ApHC-approved show, which shall be forfeited if the protest is not sustained or reimbursed if the protest is upheld.
- B. A protest relating to conduct at an ApHC-approved show for any violation of ApHC or show rules may also be made by an official or judge of the show, a Director of the ApHC, the Chief Executive Officer or the head of the ApHC Show Department to either the show committee or the Board of Directors of the ApHC. Such person making the protest shall either deliver it in writing to the show secretary or show manager within 12 hours of the time of the alleged violation or, if made directly to the ApHC Board of Directors, the written protest must be received by the ApHC within ten days after the show.
- C. The show manager or secretary at an ApHC-approved show shall forward all evidence pertaining to the protest including entry blanks, witness names and/or statements, and other sources of necessary information and evidence with the protest document and protest fee, if the protest was made to show management, to the ApHC within 3 working days (i) of their receipt of the protest or (ii) the ApHC's request of such information.
- D. A Review Committee consisting of three members of the ApHC Board of Directors with the senior member acting as chairman shall promptly hold a hearing in accordance with Appaloosa Horse Club hearing procedures.
 1. All points and awards earned at that show will be escrowed pending notification of the Review Committee decision.
 2. The involved parties may submit a written statement to the Review Committee prior to the hearing and shall have the right, in person or by counsel to appear and present evidence at the hearing and to hear and refute evidence offered by the opposing party.
 3. A written decision of the Review Committee shall be given to the involved parties not later than 10 days after the hearing. The Review Committee may impose on any person found to be guilty of any violation of these rules and regulations such penalties as the Review Committee may determine, including but not limited to those set forth in GENERAL PENALTIES AND SANCTIONS. The determination of the Review Committee shall be final and binding on all parties.

- E. A judge's decision at an ApHC-approved show is considered final. Any such judge's decision, representing his or her individual preference, is not protestable unless in violation of ApHC rules.
- F. After a judge has placed a class and signed the judge's card, a class will not be re-judged and the judge's record shall not be changed, provided that clerical corrections may be made by that judge to his/her card prior to announcement of that judge's placings in that class, so long as any such correction does not change the number of an entry in that class.
- G. Exhibitors may file a complaint against a judge by writing directly to the ApHC or by completing an exhibitor's report form at the show in question. Class placings shall not be changed after the class is completed.

611. SHOW PROTEST AT APHC-SPONSORED SHOW

- A. A protest relating to conduct at an ApHC-sponsored show for any violation of ApHC or show rules may be made by a current member in good standing of the ApHC who is also an exhibitor and/or parent of a youth exhibitor at that show. Such person making the protest shall deliver it in writing with the show secretary or show manager within 12 hours of the time of the alleged violation. The protest must specify the rule allegedly violated. No protest shall be valid unless accompanied by a deposit of \$250.00 by cash or check, delivered to the ApHC, which shall be forfeited if the protest is not sustained or reimbursed if the protest is upheld.
- B. A protest relating to conduct at an ApHC-sponsored show for any violation of ApHC or show rules may also be made by an official or judge of the show, a Director of the ApHC, the Chief Executive Officer or the head of the ApHC Show Department to either the show committee or the Board of Directors of the ApHC. Such person making the protest shall either deliver it in writing to the show secretary or show manager within 12 hours of the time of the alleged violation or, if made directly to the ApHC Board of Directors, the written protest must be received by the ApHC within ten days after the show.
- C. At an ApHC-sponsored show, the protest shall be heard by a Protest Committee consisting of one show official, an available ApHC Judge and one contestant/exhibitor representative, each of whom shall not have been involved in the dispute.
 - 1. All points and awards earned at that show will be escrowed pending the completion of the appeal process.
 - 2. The involved parties may submit a written statement to the Protest Committee prior to the hearing and shall have the right, in person or by counsel to appear and present evidence at the hearing and to hear and refute evidence offered by the opposing party.
 - 3. A written decision of the Protest Committee shall be given to the involved parties not later than 10 days after the hearing.
 - 4. An appeal of the Protest Committee decision concerning protests lodged at an ApHC-sponsored show may be made to the Board of Directors of the ApHC. The appeal must be made in writing within 15 days of the Protest Committee decision accompanied by the appropriate fee as designated in the fee schedule.
 - 5. The Appeal Committee, consisting of three members of the Board with the senior member acting as chairman, shall conduct a hearing as soon as practicable after the receipt of an Appeal Notice Form. Written notice of the date, time and location of the hearing shall be given to the involved parties not less than 15 days prior to the hearing.
 - 6. The involved parties may submit a written statement to the Appeal Committee prior to the hearing and shall have the right, in person or by counsel, to appear and present evidence at the hearing and to hear and refute evidence offered against the appeal.

- 7. A written notice of the Appeal Committee decision shall be given to the involved parties not later than 10 days after the hearing. The Appeal Committee may impose on any person found to be guilty of any violation of these rules and regulations such penalties as the Appeal Committee may determine, including but not limited to those set forth in GENERAL PENALTIES AND SANCTIONS. The determination of the Appeal Committee shall be final and binding on all parties.

- D. A judge's decision at an ApHC-approved show is considered final. Any such judge's decision, representing his or her individual preference, is not protestable unless in violation of ApHC rules.
- E. After a judge has placed a class and signed the judge's card, a class will not be re-judged and the judge's record shall not be changed, provided that clerical corrections may be made by that judge to his/her card prior to announcement of that judge's placings in that class, so long as any such correction does not change the number of an entry in that class.
- F. Exhibitors may file a complaint against a judge by writing directly to the ApHC or by completing an exhibitor's report form at the show in question. Class placings shall not be changed after the class is completed.

612. SHOW VETERINARIAN

In the event the ApHC designates a properly licensed veterinarian or veterinarians as the official veterinarian(s) for an ApHC-approved or -sponsored event including, but not limited to, the National Show and World Show, as a service to exhibitors and other persons, and any exhibitor or other person directly or indirectly employs, retains, hires or otherwise utilizes the services, advice and/or expertise of such official show veterinarian(s), the ApHC shall not in any manner or to any extent whatsoever be liable or responsible for any action, conduct, decisions or services by such official veterinarian(s) provided to any such exhibitor or other person who employs, retains, hires or otherwise utilizes the services, advice and/or expertise of such official show veterinarian(s). Such exhibitor or other person expressly releases and holds harmless the ApHC from any and all claims, demands, liabilities, losses or actions of any kind arising from or in connection with the exhibitor or other person's employment, retention, hiring or utilization of the services, advice and/or expertise of such official show veterinarian(s).

613. RULE VARIANCE

The ApHC CEO, with written approval of at least a two-thirds (2/3rds) majority of the ApHC Executive Committee, may, in their sole and absolute discretion, grant variances and/or other appropriate relief from strict compliance with ApHC approved and/or sponsored show, point, qualification, class, open, non-pro and/or youth rules and regulations only upon clear and convincing proof, supported by sworn affidavit(s) detailing the circumstances necessitating the variance request, that but for, (i) the effect of nature or natural causes that could not have been prevented by the exercise of foresight or caution, or (ii) other extraordinary circumstances beyond the affected person's control and occurring without the affected person's delay, carelessness, irresponsibility, fault or negligence, such strict compliance was reasonably possible and that the affected person took reasonable steps and action to avoid failure and/or delay of such strict compliance and that the affected person timely notified the ApHC of the likelihood and/or actual occurrence which is claimed as the reason for requesting such variance.

Rules 614-699 not assigned.

NATIONAL POINT SYSTEM

700. Points earned by a horse will be retained with the horse in case of sale or lease of the horse. In order to earn any award, the owner must be an ApHC member in good standing. If a horse is jointly owned, one owner must be a member in good standing in order for the horse to receive points. For year-end awards, the point year is January 1 through December 20.

A. The following classes are the only classes approved for national points:

1. Halter Classes

Weanling Geldings

(points accumulated for performance record only-eligible for ROM)

Yearling Geldings

Two-Year-Old Geldings

Three-Year-Old Geldings

Four-Year-Old and Older Geldings

Weanling Fillies

(points accumulated for performance record only-eligible for ROM)

Yearling Fillies

Two-Year-Old Mares

Three-Year-Old Mares

Four-Year-Old and Older Mares

Broodmares

Weanling Colts

(points accumulated for performance record only-eligible for ROM)

Yearling Colts

Two-Year-Old Stallions

Three-Year-Old Stallions

Four-Year-Old and Older Stallions

Hunter in Hand, Geldings

Hunter in Hand, Mares

Hunter in Hand, Stallions

Most Colorful at Halter

FPD Stallions

FPD Mares

FPD Geldings

2. Performance Classes

Junior Working Cow Horse

Senior Working Cow Horse

Steer Daubing

Junior Cutting

Senior Cutting

Junior Judged Tie-Down Roping

Senior Judged Tie-Down Roping

Timed Tie-Down Roping

Junior Judged Heading

Senior Judged Heading

Junior Judged Heeling

Senior Judged Heeling

Timed Heading and Heeling

Hackamore/Snaffle Bit Reining

Junior Reining

Senior Reining

Two-Year-Old Snaffle Bit Western Pleasure

(points accumulated for performance record only-eligible for ROM)

Three-Year-Old Snaffle Bit Western Pleasure

Junior Western Pleasure

Senior Western Pleasure

Junior Trail

Senior Trail

Junior Western Riding

Senior Western Riding

Two-Year-Old Snaffle Bit Hunter Under Saddle

(points accumulated for performance record only-eligible for ROM)

Three-Year-Old Snaffle Bit Hunter Under Saddle

Junior Hunter Under Saddle

Senior Hunter Under Saddle

Junior Hunter Hack

Senior Hunter Hack

Junior Saddle Seat Pleasure

Senior Saddle Seat Pleasure

Ladies' Side Saddle

Pre-Green Hunter

Green Hunter

Working Hunter

Preliminary Jumping

Jumping

Pleasure Driving

Camas Prairie Stump Race

Nez Perce Stake Race

Rope Race

Keyhole Race

Figure 8 Stake Race

Men's Heritage

Ladies' Heritage

Yearling Longe Line

(points accumulated for performance record only-eligible for ROM)

B. Optional Non-Pointed Classes

Get of Sire

Produce of Dam

Buckboard Driving

Men's Western Pleasure

Ladies' Western Pleasure

Team Penning

Hackamore/Snaffle Bit Working Cow Horse

701. SHOW PLACINGS

A. All nationally pointed open classes shall count towards national point system based awards. Points shall be earned according to the number of horses shown and judged in a class as follows.

# of horses	1st	2nd	3rd	4th	5th	6th	7th
2	½						
3-7	1	½					
8-12	2	1	½				
13-17	3	2	1	½			
18-22	4	3	2	1	½		
23-27	5	4	3	2	1	½	
28 and over	6	5	4	3	2	1	½

B. Actual participants judged shall be counted as the number of horses in a class, rather than horses entered. Scratches do not count for total number of horses when points are determined. In most cases, disqualified entries are considered judged.

C. Judges must place the top eight entries in each class except in classes of fewer than eight entries or in instances of lack of merit. No class is complete until all ties through point-earning placings are broken. If a tied contestant is disqualified in the run-off, (s)he is not to be placed any lower than the lowest position for which (s)he was tied. Contestants disqualified during the first run are not considered to be tied for a place even if there were fewer than eight entries in the class.

- D. The judge at his discretion may refuse entry into the arena for improper attire or equipment. Further, a judge may eliminate any horse or exhibitor as an entry which he/she does not feel has legitimately attempted to comply with the class rules and procedures. In such case, this entry would not be counted as an entry for the purpose of determining the number of entries in the class for national points.
- E. The winners of the weanling, yearling, 2-year-old, 3-year-old, and 4-year-old and older classes in each sex and broodmare classes (if applicable) shall be judged for Grand Champion. The second place horses in the weanling, yearling, 2-year-old, 3-year-old, 4-year-old and older and broodmare classes will line up behind the winner of each such class. After the Grand Champion has been selected, the second-place horse to that entry shall move up and stand with the winners of the other classes to be judged for Reserve Grand Champion in that sex division.
1. The Grand Champion will receive one point more than the highest pointed class in its sex division; however, in the event no points are awarded in any nationally pointed class in its sex division and at least one other horse is shown in any class eligible to receive national points in its sex division, the Grand Champion shall receive one point.
 2. The Reserve Grand Champion will receive 1/2 point more than the highest pointed class in its sex division; however, in the event no points are awarded in any nationally pointed class in its sex division and at least one other horse is shown in any class eligible to receive national points in its sex division, the Reserve Grand Champion shall receive 1/2 point.

Example:

Consider the following example when calculating points earned by horses winning Grand or Reserve Champion titles. In this example, the following classes and entries are held at an ApHC-approved show:

- Weanling Fillies - 2 entries (1/2 point earned by first place)
- Yearling Fillies - 2 entries (1/2 point earned by first place)
- Two-Year-Old Mares - 2 entries (1/2 point earned by first place)
- Three-Year-Old Mares - 4 entries (1 point earned by first place, 1/2 point earned by second place)
- Aged Mares - 2 entries (1/2 point earned by first place)

The first and second place horses in the above classes return to be judged for Grand and Reserve Champion. The highest pointed class in the sex division is the Three-Year-Old Mares class in which first place received 1 point. Therefore, the Grand Champion should receive a total of 2 points (which is 1 more point than the highest pointed class in the sex division). The Reserve Champion should receive a total of 1 1/2 points (which is 1/2 point more than the highest pointed class in the sex division).

For this example, the first place horse in Aged Mares wins Grand Champion. She should receive a total of 2 points. Since this mare already has 1/2 point for winning her class, she will receive 1 1/2 more points for being named Grand Champion, bringing her point total to 2 points for the show. That gives her 1 point more than the winner of the Three-Year-Old Mares class.

The second place Aged Mare then goes on to win Reserve Champion. She should receive a total of 1 1/2 points. Since the Reserve Champion mare didn't earn any points in her class (she was second of two horses in Aged Mares), she will receive a total of 1 1/2 points for being named Reserve Champion. That gives her 1/2 point more than the winner of the Three-Year-Old Mares class.

Points from age division		+	Points from Grand or Reserve Title	=	Total
Grand Mare	1/2	+	1 1/2	=	2.0
Reserve Mare	0	+	1 1/2	=	1 1/2

702. NATIONAL AWARDS

Awards (with the exception of Medallion awards) will be mailed to the current first-listed (in cases of joint ownership) owner on record with the ApHC as of December 31, of the year earned.

A. Class Categories for Award Calculation

1. Performance Categories

a. Pleasure Classes

- Western Pleasure (Junior and Senior)
- Three-Year-Old Snaffle Bit Western Pleasure
- Two-Year-Old Snaffle Bit Western Pleasure (points accumulated for performance record only-eligible for ROM)
- Hunter Under Saddle (Junior and Senior)
- Three-Year-Old Snaffle Bit Hunter Under Saddle
- Two-Year-Old Snaffle Bit Hunter Under Saddle (points accumulated for performance record only-eligible for ROM)
- Saddle Seat Pleasure (Junior and Senior)
- Hunter Hack (Junior and Senior)
- Pleasure Driving
- Yearling Longe Line (points accumulated for performance record only-eligible for ROM)

b. Working Classes

- Hackamore Snaffle Bit Reining
- Reining (Junior and Senior)
- Western Riding (Junior and Senior)
- Pre-Green Hunter
- Green Hunter
- Working Hunter
- Preliminary Jumping
- Jumping
- Trail (Junior and Senior)

c. Game Classes

- Nez Perce Stake Race
- Camas Prairie Stump Race
- Rope Race
- Keyhole Race
- Figure 8 Stake Race

d. Cattle Classes

- Hackamore/Snaffle Bit Working Cow Horse (prior to 2001)
- Working Cow Horse (Junior and Senior)
- Cutting (Junior and Senior)
- Timed Tie-Down Roping (Junior and Senior)
- Judged Tie-Down Roping (Junior and Senior)
- Timed Heading and Heeling (Junior and Senior)
- Judged Heading (Junior and Senior)
- Judged Heeling (Junior and Senior)
- Steer Daubing

e. Specialty Classes

- Ladies' Side Saddle
- Men's Heritage
- Ladies' Heritage

2. Halter Class Category

a. Halter Classes

- Halter Stallions (all approved age divisions)
- Halter Mares (all approved age divisions)

Halter Geldings (all approved age divisions)
 Hunter in Hand, Stallions
 Hunter in Hand, Mares
 Hunter in Hand, Geldings
 Most Colorful at Halter
 FPD Stallions
 FPD Mares
 FPD Geldings

B. Register of Merit (ROM)

Horses are awarded the ROM when they have earned at least 10 points in an open performance or halter class. Points earned in Two-Year-Old Snaffle Bit Western Pleasure, Two-Year-Old Snaffle Bit Hunter Under Saddle, Yearling Longe Line, weanling halter divisions and FPD halter classes are eligible to count toward a ROM. A minimum of five points must be earned under three or more judges. Only one ROM is available regardless of age in classes which are divided as junior and senior. Points earned toward a ROM carry from junior to senior, and from 2-year-old to 3-year-old. Points do not carry over from 3-year-old to junior. A horse can only earn 1 halter ROM.

C. ApHC Champion

A certificate for ApHC Champion will be awarded when a horse has earned 50 points, provided that at least 25 of the points have been earned in halter and at least 25 points have been earned in at least three different performance classes. At least 10 of the halter points and 10 of the performance points must have been earned under three or more judges.

D. ApHC Supreme Champion Horse

An award as ApHC Supreme Champion Horse will be awarded when a horse has earned at least 100 points, with at least 40 points earned in halter classes and at least 60 points earned in performance classes. No more than 10 points can be from one performance class and the horse must have at least one ROM in four of the five categories of performance classes. A minimum of five different judges is required. Awards will be mailed to the first listed current owner on record with the ApHC as of December 31 of the year earned.

E. ApHC Superior Event

A certificate for a Superior Event horse will be awarded when a horse receives the following points in each event.

Halter.....	100
Hunter in Hand.....	50
Most Colorful at Halter	100
Three-Year-Old Snaffle Bit Western Pleasure.....	50
Western Pleasure.....	100
Three-Year-Old Snaffle Bit Hunter Under Saddle	50
Hunter Under Saddle.....	100
Saddle Seat Pleasure	50
Pleasure Driving.....	50
Hackamore/Snaffle Bit Reining.....	50
Reining	50
Western Riding.....	50
Green Hunter.....	50
Hunter Hack.....	50
Working Hunter	50
Preliminary Jumping.....	50
Jumping.....	50
Trail.....	50
Nez Perce Stake Race	50
Camas Prairie Stump Race	50
Rope Race.....	50

Keyhole Race.....	50
Figure 8 Stake Race	50
Working Cow Horse.....	50
Cutting	50
Timed Tie-Down Roping	50
Judged Tie-Down Roping.....	50
Timed Heading & Heeling.....	50
Judged Heading	50
Judged Heeling	50
Steer Daubing.....	50
Ladies' Side Saddle.....	50
Heritage.....	50

F. ApHC Versatility Champion

A certificate for ApHC Versatility Champion will be awarded when a horse has earned five ROM's only one of which will be a halter ROM. All ROM's acquired prior to January 1, 1995, shall be counted toward Versatility Champion. Additional halter ROM's (more than 1) acquired in 1995 shall not be counted toward Versatility Champion.

G. Production Awards

Production records will be kept on any breed of horse that appears on the approved list by the ApHC to produce an Appaloosa.

1. ApHC Performance Dam - A certificate for ApHC Performance Dam will be awarded when three of a mare's produce have earned either an ApHC Champion or an ApHC Versatility Champion award.
2. ApHC Performance Sire - A certificate for ApHC Performance Sire will be awarded when eight of a stallion's get have earned either an ApHC Champion or an ApHC Versatility Champion award.

H. Medallion Awards System

The medallion system is a means of recognizing Appaloosa horses, properly registered within the rules of the ApHC, which have proven their superiority in the field of performance, halter, distance riding and racing.

1. In order for a horse to qualify for a medallion or year-end racing award, one owner must be a member of the ApHC for the qualifying year. Smaller replicas are awarded to the first listed owner, provided one owner is an active member of the ApHC for the qualifying year, and to the first listed breeder, provided one breeder was an active member of the ApHC for the year the horse was bred. Only one owner medallion and one breeder medallion per qualifying horse will be awarded regardless of the number of co-owners or co-breeders. In cases where the owner and breeder of a qualifying horse are the same, only one owner/breeder medallion will be awarded. Medallions will be awarded to breeders who meet all qualifications as long as the dam is registered with the ApHC or one of the approved breed associations. Owners and breeders must notify the ApHC, within a year of qualification, if an earned medallion was not received. Medallions for National and World Show wins will be mailed to the first listed owner on record with the ApHC at the time of the win. Year-end high point medallions will be awarded to the first listed owner on record with the ApHC as of December 31 of the qualifying year. A horse is eligible to win more than one medallion per category.
2. Medallions to be awarded as follows:
 First Category-Bronze
 Second Category-Silver
 Third Category-Gold
 Fourth Category-Diamond Studded

Example: If a horse started out in the field of racing and was eligible for a medallion as a 2-year-old, it would be entitled to a bronze medallion. If it were trained in performance and won the reining class at the World Championship

Appaloosa Show, it would receive a silver medallion. If it competed later in distance trail riding and compiled a sufficient number of miles, it would receive a gold medallion. If the horse competed and won the aged stallion class at the National Appaloosa Horse Show, it would be awarded the diamond studded medallion. The medallion award goes to the horse. In the event the horse is sold, the medallion goes with the horse unless the parties contract differently.

3. A medallion will be issued to the winner of each designated class both at the World Championship Appaloosa Show and the National Appaloosa Show, provided at least three entries are shown in the class. Any horse who is the high point horse at the end of the year through the National Point System will receive a medallion, provided the horse has earned at least five points in that event, except for in those classes excluded in rule 700. Ties for year-end high point awards will not be broken. In halter and performance, medallions will be awarded to the owner of record on the date an award is earned.
4. An International Medallion will be issued to the winner of each designated class at the European Championships provided at least 3 entries are shown in the class.
5. In the field of distance riding (endurance and competitive trail riding) medallions will be issued to eligible horses completing 350 miles beginning December 1 and ending November 30 each year. In Distance Riding, medallions will be awarded to the first listed owner of record on the date the required mileage was completed.
6. In the field of racing, medallions will be issued to the top three eligible horses in each age and sex category. Medallion points will be figured using a formula of the number of wins times the amount of money earned as officially recorded by the Appaloosa Horse Club for the qualifying year. A horse must be registered with Regular (#) or CPO (CN) registration classification, or have been issued a Performance Permit prior to racing in the qualifying year, to be eligible to earn racing medallions. Racing medallions are awarded to the first listed owner or lessee on record on December 31 of the qualifying year.

I. Production Plaques

1. Production plaques may be earned by horses registered with the ApHC providing the owner is an active member of the ApHC for the qualifying year. If a stallion sires 12 different bronze medallion winners, a bronze production plaque will be issued. If a stallion sires 24 different horses that win bronze medallions, a bronze Superior Sire Production Plaque will be issued. If a stallion sires 40 different horses that win bronze medallions, the stallion will be issued a bronze Supreme Sire Production Plaque, will be issued, and will be inducted into the Appaloosa Hall of Fame. If a mare produces three different bronze medallion winners, a bronze production plaque will be issued. If a mare produces four different bronze medallion winners, the mare will be issued a bronze Superior Dam Production Plaque. If a mare produces five different bronze medallion winners, the mare will be issued a bronze Supreme Dam Production Plaque and will be inducted into the Appaloosa Hall of Fame.
2. If a stallion sires eight different silver medallion winners, a silver production plaque will be issued. If a stallion sires 12 different horses that win silver medallions, the stallion will be issued a silver Superior Sire Production Plaque. If a stallion sires 16 different horses that win silver medallions, the stallion will be issued a silver Supreme Sire Production Plaque and will be inducted into the Appaloosa Hall of Fame. If a mare produces two silver medallion winners, a silver production plaque will be issued. If a mare produces three different horses that win silver medallions, the mare will be issued a silver Superior Dam Production Plaque. If a mare produces four different horses that win a silver medallion, the mare will be issued a silver Supreme Dam Production Plaque and will be inducted into the Appaloosa Hall of Fame.

3. If a stallion sires four different gold medallion winners, a gold production plaque will be issued. If a stallion sires six different horses that win gold medallions, the stallion will be issued a gold Superior Sire Production Plaque. If a stallion sires eight different horses that win gold medallions, the stallion will be issued a gold Supreme Sire Production Plaque and will be inducted into the Appaloosa Hall of Fame. If a mare produces one gold medallion winner, a gold production plaque will be issued. If a mare produces two different horses that win gold medallions, the mare will be issued a gold Superior Dam Production Plaque. If a mare produces three different horses that win a gold medallion, the mare will be issued a gold Supreme Dam Production Plaque and will be inducted into the Appaloosa Hall of Fame.
4. If a stallion or mare sires or produces a diamond-studded medallion winner, a diamond-studded production plaque will be issued. The winner of a diamond medallion will be inducted into the Appaloosa Hall of Fame. The sire and dam of a diamond medallion winner will also be inducted.

J. Induction of Geldings into Hall of Fame

A gelding will automatically be inducted into the Hall of Fame if he has earned 14 bronze medallions or 9 silver medallions or 2 gold medallions.

K. International Top Ten Listing

The ApHC maintains a listing of top point earners at ApHC-approved international shows (those held outside of the United States) in the following classes: hunter in hand (stallions, mares, geldings), halter (yearlings, two-year-olds, three-year-olds, aged) stallions, mares and geldings, broodmares, most colorful at halter, reining (junior, senior, non-pro, youth), trail (junior, senior, non-pro, youth), western pleasure (junior, senior, non-pro, youth), hunter under saddle (junior, senior, non-pro, youth), halter mares (non-pro, youth), halter geldings (non-pro, youth) and halter stallions (non-pro). Year-end awards are provided to top point earners provided that the winner has earned at least 5 points under at least three different judges. In order to earn points for the international top ten, the horse must be owned by an ApHC member who resides outside of the United States and must be shown at ApHC-approved shows held at locations outside of the United States.

703. WORLD CHAMPIONSHIP APPALOOSA SHOW

A. QUALIFYING REQUIREMENTS—OPEN CLASSES

Under the National Point System, individual owners may qualify horses by meeting the minimum number of point requirements if they are current members in good standing in the ApHC. Those shows which have gained ApHC approval and have met all requirements will count for national points.

1. Under the regional club system, a regional organization officially recognized as an affiliate in good standing with the ApHC may qualify up to its top five (5) horses for the World Championship Appaloosa Show in each class. In order for a regional club to be eligible to nominate horses for the World Championship Appaloosa Show under the regional qualifying system, that club must have sponsored, pointed or co-sponsored at least one ApHC-approved show in that qualifying year and that regional club may only nominate horses in classes in which such horses exhibited in that club's sponsored, pointed or co-sponsored show.
2. Regional clubs may design their own point system but must meet the following conditions:
 - a. Each show used for regional qualifying points must be an ApHC-approved show. Organizations, clubs or individuals desiring to sponsor or stage shows which will be approved by the ApHC, and which will include the awarding of national points to the top-placing horses entered in the show must obtain approval from the Appaloosa Horse Club.

- b. Owners of horses qualifying under this regional provision must be active members of the regional organization submitting the nomination.
 - c. Horses nominated under the regional club system must earn one national point in the class to be entered, unless the national point qualification for that class is zero.
 - d. A horse may receive only one (1) World Show invitation per class. If it earns an invitation under the National Point System, it becomes ineligible to be nominated by a Regional Club for that class. In order to receive a World Show invitation as a result of the Regional Club nomination, the horse must have earned one (1) National Point in that class. Only the top five (5) ranking horses from the Regional Club, regardless of whether the horse qualified under the National Point System, may receive the Regional Club invitation. In the event that all of the Regional Club's top five (5) horses qualify under the National Point System, no horse would qualify from the Regional Club for that class. If a horse qualifies in more than one Regional Club, it must use whichever qualification shows up first when Regional Clubs are listed in alphabetical order.
 - e. An exception may be made to the one (1) National Point requirement if it is documented on forms requested from and provided by the ApHC and submitted by the owner of the horse by the World qualifying point cutoff deadline that the horse was entered and attempted in good faith to earn points under at least five (5) different judges in that class during that qualifying year but could not earn the required one (1) point because there were no other entries in that specific class.
3. Point cut-off date for qualifying under both the National Point System and the regional club system is August 31. For shows after that date, the points shall be counted toward the following year. All show results, regional club nominations and current regional membership lists must be sent by certified mail return receipt or other guaranteed mail service, and must be in the ApHC office by the following deadlines:
- a. Shows held prior to August 1 – all results, nominations and membership lists must be received by the ApHC no later than August 15.
 - b. Shows held on or after August 1 – all results, nominations and membership lists must be received by the ApHC no later than September 10.
 - c. Shows whose approved Appaloosa classes begin on or before August 31 and run continuously into September will count toward the current year's World Show qualifications. These show results also must be in the ApHC office by September 10, NO EXCEPTIONS.
 - d. If the above requirements are not in the ApHC office by September 10, each show will be fined \$100 and the points will be carried over to the next year.

- 4. Each World Show class champion will automatically qualify to compete in that class at the next World Show.
- 5. Stallions that are gelded shall retain halter stallion points earned during the qualifying year (September 1–August 31) to be used toward qualifying for the World Show in the halter geldings class.

B. QUALIFYING REQUIREMENTS — NON-PRO CLASSES

Beginning in 2007, non-pros must qualify to exhibit at the World Championship Appaloosa Show by earning one national point in any age division (19 & over, 35 & over, masters) of a non-pro class which will entitle the non-pro to exhibit in any age division of that class, with the exception of halter. In halter, non-pros must earn one national point in any non-pro halter sex division (not per class) in order to be eligible to compete in any halter class in that sex division, excluding weanlings competing in weanling halter classes and weanlings and yearlings competing in hunter in hand classes.

- 1. Novice classes are non-qualifying classes.

- 2. Points earned September 1 through August 31 of the following year will count toward qualification for that year's World Championship Appaloosa Show.
- 3. A complete list of classes and qualifying requirements is included in Rule 907.C.3.
- 4. Each World Show Champion will automatically qualify to compete in that class at the next World Show.

C. ELIGIBILITY

- 1. Exhibitors and owners must be members of the ApHC and of a regional club in order to compete at the World Show. Persons competing shall be defined to include owners, trainers, and exhibitors.
 - a. If a horse is owned by a corporation, the person signing for the corporation must be a current member in good standing of the ApHC. If a horse is owned by two or more people, at least one of the owners must be a current member in good standing of the ApHC.
- D. In the case of a Non-pro exhibitor or a horse not meeting World Show qualification requirements due to a major medical condition of the exhibitor that has prohibited them from attending regional shows in an effort to get qualified, the exhibitor may apply for a variance from the ApHC to bypass qualification requirements and enter the World Show. Any variance application may be granted or denied at the discretion of the ApHC Executive Committee upon recommendation by the ApHC Chief Executive Officer. The Executive Committee may impose any conditions on any variance approval that are deemed advisable. The variance application must be accompanied by original dated documents from the attending physician and will be verified by the ApHC Chief Executive Officer. If any variance application is granted by the Executive Committee, the ApHC Chief Executive Officer will issue a letter to the Non-pro or owner of the qualifying horse, granting the variance, listing the affected class (es) and stating any conditions. This variance will expire immediately following the completion of the World Show in the year it was granted and can be revoked at the discretion of the ApHC Executive Committee at any time. The variance application must be received no later than August 31 or it shall not be considered.

Rules 704-709 are not assigned.

710. NATIONAL POINT SYSTEM

WORLD SHOW QUALIFYING POINTS

A. HALTER CLASSES	POINTS REQUIRED FOR WORLD SHOW
Weanling Geldings.....	0
Yearling Geldings.....	3
Two-Year-Old Geldings.....	5
Three-Year-Old Geldings.....	5
Aged Geldings.....	9
Weanling Fillies.....	0
Yearling Fillies.....	8
Two-Year-Old Mares.....	7
Three-Year-Old Mares.....	6
Aged Mares.....	7
Broodmares.....	2
Weanling Colts.....	0
Yearling Colts.....	7
Two-Year-Old Stallions.....	6
Three-Year-Old Stallions.....	4
Aged Stallions.....	6
Hunter in Hand, Stallions.....	2
Hunter in Hand, Mares.....	3

Hunter in Hand, Geldings	3
Most Colorful at Halter	5

B. PERFORMANCE CLASSES **POINTS REQUIRED FOR
WORLD SHOW**

Junior Working Cow Horse	2
Senior Working Cow Horse	2
Hackamore/Snaffle Bit Reining	2
Junior Reining	3
Senior Reining	3
Junior Western Riding	3
Senior Western Riding	4
Two-Year-Old Snaffle Bit Hunter Under Saddle	0
Three-Year-Old Snaffle Bit Hunter Under Saddle	2
Junior Hunter Under Saddle	7
Senior Hunter Under Saddle	9
Junior Hunter Hack	0
Senior Hunter Hack	0
Saddle Seat Pleasure	3
Men's Heritage	2
Ladies' Heritage	2
Pleasure Driving	0
Two-Year-Old Snaffle Bit Western Pleasure	0
Three-Year-Old Snaffle Bit Western Pleasure	2
Junior Western Pleasure	10
Senior Western Pleasure	8
Junior Trail	3
Senior Trail	7
Preliminary Jumping	0
Jumping	0
Pre-Green Hunter	0
Green Hunter	0
Working Hunter	0
Junior Cutting	2
Senior Cutting	2
Timed Tie-Down Roping	3
Judged Tie-Down Roping (Junior & Senior)	3
Timed Heading and Heeling	4
Judged Heading (Junior & Senior)	3
Judged Heeling (Junior & Senior)	3
Steer Daubing	3
Figure 8 Stake Race	4
Camas Prairie Stump Race	6
Nez Perce Stake Race	4
Keyhole Race	3
Rope Race	3
Yearling Longe Line	0

C. NON-POINTED, NON-QUALIFYING CLASSES

Ladies' Western Pleasure	0
Men's Western Pleasure	0
Team Penning	0
Freestyle Reining	0
Hunter In Hand, Yearlings	0

711. DISQUALIFICATIONS FOR PERFORMANCE & HALTER

- A. Fall of horse and/or exhibitor shall result in disqualification, except as may be otherwise stated in individual class rules and except in halter classes. A horse is considered to have fallen when the shoulder and flank or quarters on the same side have touched the ground or an obstacle and the ground. An exhibitor is considered to have fallen when he/she is separated from his/her horse, that has not fallen, in such a way that he/she must remount or vault into the saddle.
- B. Any contestant who is assisted by another person inside the arena or show ring will be disqualified, excluding Leadline and excluding an exhibitor who needs assistance with a loose horse in halter. This does not apply to a contestant in a team event, such as heading and heeling, cutting, or driving.
- C. In all classes and all divisions of classes, if a horse's mouth is found to be bloody, disqualification is at the judge's discretion. Judges may also, at their discretion, disqualify a horse anytime it is exhibited with an open, raw or bleeding sore that repeatedly comes in contact with the hackamore.
- D. Any time a horse's mouth is tied or fastened in a performance class, it shall be disqualified.
- E. Any exhibitor striking or hitting the horse forward of the cinch with any object (other than the hands) shall constitute immediate disqualification from any performance class (exception: Hunter and Jumpers). Any exhibitor striking the horse on the head with anything, including the hands, will be subject to disqualification. This rule will be strictly enforced by the judge. These objects include romal, spurs, whip, bat, quirt, crop, switches, wire, reins, or any other object.
- F. The judge may disqualify any animal that is not sufficiently gentle to be shown without danger to the public, show officials and/or exhibitors. The judge shall have the authority to dismiss any entry from the arena if the entry is not under sufficient control.
- G. No exhibitor may be tied, buckled or fastened in the saddle in any manner or by any means. (Exception: See Rule 608.K)
- H. Exhibitors may be disqualified for not following judge's instructions.
- I. Any horse not following the exact pattern required in any class will be disqualified unless otherwise specified under class rules.
- J. Lack of required appointments (personal attire or tack) will be cause for disqualification in any class specifying required appointments.
- K. Use of prohibited appointments is cause for disqualification.
- L. If an entry is handicapped by a cast shoe or equipment failure in a timed or judged event which prevents him from continuing the class without stopping to repair it, he shall be disqualified except as may be stated in individual class rules. Reruns will not be allowed in instances of equipment failure.
- M. Entry numbers must be assigned to horses, not exhibitors, and the exhibitors must display the correct number assigned for the horse being exhibited at ApHC-approved shows. Failure by exhibitor to display the correct number and in a visible manner while being judged shall result in disqualification.
 1. In halter, showmanship, bareback horsemanship, saddle seat and ladies' side saddle classes, the number must be worn on the exhibitor's back.
 2. In driving classes, the number must be displayed on both sides of the vehicle shafts.
 3. In western performance classes, English performance classes (except saddle seat), hunter hack, over fence classes and heritage, each exhibitor must have two numbers and one must be placed on each side of the saddle or saddle pad.
- N. Coloring of the hooves that would cover and/or hide the natural characteristics of the hooves (clear hoof dressing will be allowed).
- O. The use of shoe polish, dye, spray paint and/or similar substance of any color on the body, head, legs, mane or tail of the horse shall be considered as artificial coloring and shall result in disqualification of the horse (except as otherwise stated in games and heritage class rules.)

- P. Except for hackamore/snaffle bit classes or junior horses shown with an acceptable hackamore or snaffle bit, only one hand may be used on the reins, and the hand must not be changed (except as allowed in TRAIL & Gaming Classes General Rules). The hand is to be around the reins; index finger only between split reins is permitted. Violation of this rule is an automatic disqualification from the class.
- Q. Judges may, at their discretion, disqualify horses that appear sullen, dull, lethargic, emaciated, drawn or overly tired. Such disqualification shall be reported to show management who shall immediately report the matter to the ApHC.
- R. Judges may, at their discretion, disqualify horses that have been inhumanely treated per Rule 30.A. Such disqualification shall be reported to show management who shall immediately report the matter to the ApHC.
- S. Exhibitors are not allowed to wear earpieces or to have wireless contact with anyone during the conduct of a class. Exhibitors in violation of this rule shall be disqualified. **Exceptions may be made for challenged riders with ApHC documentation.**

712. LAMENESS

- A. Rules regarding lameness are adopted to protect the health of Appaloosas exhibited in ApHC-approved and -sponsored shows.
- B. Obvious lameness shall be cause for disqualification in all classes. Obvious lameness is:
 - 1. Consistently observable at a trot under all circumstances;
 - 2. Marked nodding, hitching, or shortened stride;
 - 3. Minimal weight-bearing in motion and/or at rest and inability to move.
- C. The judge shall examine and check for lameness all horses brought into any class. This is essential regardless of whether or not the competition indicates it is necessary.
- D. A judge's decision as to the lameness of a horse is not protestable.

713. HALTER CLASSES

A. HALTER CLASS GENERAL RULES (apply to all halter sex and age divisions, most colorful at halter, FPD halter and group halter classes, unless otherwise stated)

- 1. Any horse that has a Certificate of Registration that is noted with the white markings designation "This horse has white markings designated under ApHC rules as an undesirable trait" is ineligible to compete in any halter class at ApHC-approved and/or -sponsored events.
- 2. Equipment:
 - a. Horses to be shown in a halter only. All tack shall be neat, clean and well cared for.
 - b. Lip chains are allowed. Unsecured keepers may be used as long as at least two links of chain remain outside of halter before attachment of keeper or leather part of lead shank. Violation of this minimum restriction shall result in disqualification from the class at the discretion of the judge(s). As well, a horse whose mouth is found to be bloody shall be disqualified at the judge's discretion.
 - c. The use of whips or bats of any type shall not be permitted, except in hunter in hand.
- 3. Attire:
 - a. In halter, it is mandatory to wear appropriate western attire, which includes long-sleeved shirt with collar (band, standup, tuxedo, etc.), western hat, cowboy boots, and pants (slacks, jeans, trousers, etc.). No skirts or dresses. Chaps and spurs are prohibited.
- 4. Class Conduct:
 - a. Horses shall enter ring and be lined up at the discretion of the judge. Entries shall be judged individually, standing and also at a walk and trot on the line. Horses shall be led directly to and away from the judge.

Additionally, the judge shall inspect the trot from a direct side angle. Horses will be lined up head to tail for individual inspection by the judge. In all halter classes and judging of grand and reserve champion, the judge shall inspect each horse from the front, rear and both sides. Horses should stand squarely and naturally and are not to be stretched.

- b. Emphasis shall be placed on type, conformation, action, substance, quality and manners. Transmissible weakness and/or conditions as follows shall be counted strongly against animals, such as impaired vision, parrot mouth, ringbone, spavin, thoroughpins, curb, and bowed tendons. Stallions three (3) years old and older shall have both testicles visibly descended. Monorchidism and cryptorchidism shall be considered undesirable traits and shall be judged accordingly. This also applies to horses shown in hunter in hand.
- c. Exhibitors shall not be penalized for touching or moving a horse's leg with their hands.
- d. Horses must be handled and shown by one person only.
- e. Unruly or ill-mannered horses may be excused from the ring.
- f. Horses entered in all events must be serviceably sound and in good condition. Small blemishes on account of accident, for example, wire cuts and brands, are not to be counted against the horse.
- g. If a horse falls or an exhibitor needs assistance with a loose horse, they will not be disqualified from the class.
- 5. A horse may be exhibited in only one point earning age/sex class including broodmares. Horses entered in their respective age/sex or broodmare class may also enter Most Colorful at Halter, the appropriate sex Hunter in Hand class and FPD halter.
- 6. Open Halter classes include:
 - a. Weanlings (foaled in calendar year of show)
 - 1. fillies
 - 2. colts
 - 3. geldings
 - b. Yearlings (foaled in calendar year preceding year of show)
 - 1. fillies
 - 2. colts
 - 3. geldings
 - c. Two-Year-Olds
 - 1. mares
 - 2. stallions
 - 3. geldings
 - d. Three-Year-Olds
 - 1. mares
 - 2. stallions
 - 3. geldings
 - e. Four-Year-Olds & Older
 - 1. mares
 - 2. stallions
 - 3. geldings
 - f. Broodmares
 - 1. Mares that have produced an ApHC-registered Appaloosa foal in the current year or the previous year are eligible to be shown in the broodmare class, except a mare's production requirements cannot be satisfied as a result of that mare's donation of an embryo to another mare. Once a broodmare has produced three naturally-born ApHC-registered foals, she is eligible to be shown in the broodmare class for the rest of her life. Mares may be any age. Mares shown in the Broodmare class are not eligible to be show in any other mare class (listed above) at the same show.

- g. Grand Champion (chosen from first place class winners in each sex division, except as noted in 7.b below)
 - 1. mare
 - 2. stallion
 - 3. gelding
 - h. Reserve Grand Champion (chosen from second place class winner in the Grand Champion's class and first place winners in all other classes in that sex division, except as noted in 7.b below)
 - 1. mare
 - 2. stallion
 - 3. gelding
7. Grand and Reserve Grand Champion class conduct: When judging of all classes in a halter division has been completed, all first and second place class winners of that sex division (weanling, yearling, 2-year-old, 3-year-old, 4-year-old and older and broodmares—if applicable), shall return to the ring, with first-place class winners in one line and second-place horses from each class in another line. See rule 701.E for explanation of points awarded in Grand and Reserve classes.
- a. It is mandatory that the judge select a Grand Champion and Reserve Champion in each sex division in open.
 - b. The judge shall select the Grand Champion mare, stallion or gelding from the first-place class winners in the respective sex division. If the first place horse does not return for any reason, the second place horse will move up to the first place line and be considered for Grand and Reserve. The third place horse cannot move up to second place in the class. All first place horses will retain points in their respective classes.
 - c. The ring steward shall take the second-place horse in the class from which the Grand Champion had been selected and place it in the line with the first-place class winners, to be judged equally for the title of Reserve Champion mare, stallion or gelding in the respective sex division.
8. Halter classes shall not be combined to include horses of different ages or sexes, except in most colorful at halter and group halter classes.

B. MOST COLORFUL AT HALTER

- 1. Class Conduct:
 - a. Horses to be judged 60% on color, 40% on conformation, action, substance, quality and manners. Horses registered with CPO (CN) or N (Non-Characteristic) registration classification or horses that have been issued a Performance Permit are ineligible to compete in Most Colorful at Halter.
 - b. Entries shall be judged individually standing, and also at a walk and trot on the line.

C. FPD HALTER

- 1. Class Conduct:
 - a. Horses to be judged 40% on color, 60% on conformation, action, substance, quality and manners. Horse must have FPD papers to enter this class. No applications for registration or "work in progress" papers.
 - b. Points earned in FPD halter classes will be recorded on the horse's performance record and count toward lifetime awards and year-end medallions.

D. GROUP HALTER CLASSES

- 1. GET OF SIRE. Three get, any age, either sex, sired by the same registered Appaloosa stallion (sire not to be shown), shall constitute one entry. Get need not be owned by the same exhibitor. The get of a deceased sire or a sire which has been gelded are ineligible.
- 2. PRODUCE OF DAM. Two produce, any age, either sex, of same registered Appaloosa mare (dam not to be shown), shall constitute one entry. Produce need not be owned by same exhibitor. Produce of deceased or spayed dam are ineligible.

- 3. If a Pedigree Certificate (PC) registered horse qualifies and is changed to Non-Characteristic (N) classification, the offspring may show in Get of Sire or Produce of Dam classes if they have been properly registered.

E. HUNTER IN HAND

- 1. Equipment:
 - a. English headstall equipped with any acceptable single-rein English bit (see ENGLISH PERFORMANCE specifications) and that complies with appropriate equipment rules for the age of the horse shown. Notwithstanding the above, English bridle is mandatory on horses two years old and older and plain leather halter is required on weanling and yearling horses.
 - b. For horses one year old and younger, halters are mandatory. The halter and lead must be halter of plain leather. The chain on the lead may be over the nose or under the chin; however, no chains are allowed in the horse's mouth and no lip chains are allowed.
 - c. The use of a crop or bat is optional.
- 2. Attire:
 - a. Attire of the handler should permit free movement. Color may be chosen to complement horse, but should be conservative. Suitable attire shall be a collared polo shirt or collared dress shirt (solid colored and either white or another conservative color), vest, tie and gloves (optional). Dress pants should be loose enough in which to run. If a belt is worn, it should be a plain belt, not of western type or style. Jeans are forbidden. Running shoes or paddock boots are required.
- 3. Class Conduct:
 - a. Horses will be judged individually on the triangle, following a posted order.
 - b. The horses will approach the judging area (A) and set up for inspection in the "open" position (i.e. with all four legs of the horse visible by the judge standing on either side of the horse). The judge shall inspect each horse from the front, rear and both sides. Transmissible weakness and/or conditions shall be counted strongly against animals (See Rule 713.A.3.b).
 - c. At the judge's request, the horse will then walk the small triangle ABCA. The horse will continue on at a trot following the large ADEA.
 - d. At the completion of the judging, the handler will lead the horse away from the judging area. As one horse leaves, the next one will enter the judging area promptly.
 - e. When all horses in the class have completed the triangle, they may be lined up for judges to place, or "ringing" (walking in a large group circle around the judges) may be used.
 - f. An exhibitor may show more than one horse in a class on the triangle. In this case, a helper may assist in bringing the horses back for ringing or final inspection.

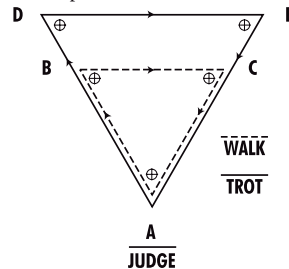

70 to 90 feet (21.34 to 27.43 m) between corner markers

- 4. Scoring System: 60% movement, 30% conformation, 10% temperament.

5. If a horse knocks over a cone or marker, they are to be scored accordingly. This does not constitute immediate disqualification but at the judge's discretion can be penalized in the temperament or movement score.
6. If a horse or exhibitor falls, they are to be scored accordingly. This does not constitute immediate disqualification but at the judge's discretion can be penalized in the temperament or movement score.
7. If a horse is off pattern either by completing the large triangle ADEA before the small triangle ABCA, by not displaying the correct gait while completing the corresponding triangle or by not submitting to inspection prior to completing the pattern, the entry shall be disqualified.
 - a. An appropriate penalty shall be assessed at the judge's discretion for break of gait during completion of the pattern, but this shall not constitute off pattern or immediate disqualification.

714. GENERAL PERFORMANCE RULES

- A. Horses entered in all events must be serviceably sound and in good condition. Small blemishes on account of accident, for example, wire cuts and brands, are not to be counted against the horse.
- B. No horse is to be penalized for the manner in which he carries his tail nor for normal response with his tail to cues from his exhibitor or when changing leads. A judge may at his discretion, penalize a horse for excessive or exaggerated switching or wringing of the tail or for a seemingly dead tail that merely dangles between the legs and does not show normal response.
 1. Tails may be lengthened by hair-to-hair attachment only, with no attachments of any kind to the tailbone. Artificial tails consisting of fabric and hair are permissible.
 2. Weighted tails are permissible, provided they meet the following criteria:
 - a. Tail attachment is made hair to hair.
 - b. Humane conditions are maintained as outlined in Rule 30.A.1.
 - c. The designated judge or equipment steward shall determine if the tail meets the criteria or if the weight of the attachment is excessive. Their decision will be final.
- C. Judging begins when the entrant enters the arena and ends when all judging is complete. After a judge has placed a class and signed the judge's cards, a class will not be re-judged and the judges record shall not be changed. If clerical corrections, initiated by show official(s) (typically announcer, but could also be show secretary, manager or ring steward) are made to a judge's card, they must be approved and initialed by the judge. Once a judge's placings have been announced, no clerical corrections shall be made.
- D. In all classes where backing is required, the judge may, at his discretion, require the backing of only the finalists in the class.
- E. No rail class shall have a mandatory starting direction. The direction shall be at the discretion of the judge. The direction of reversing shall be to the inside unless otherwise specified by the judge. Horses may be required to reverse at a walk or trot at the discretion of the judge, but horses shall not be asked to reverse at the lope. It is permissible for a judge to require an exhibitor to extend the walk, trot or lope unless otherwise specified.
- F. A judge may require any contestant to repeat his performance of any or all the various parts of a required pattern(s) except in timed events and unless otherwise specified under class rules.
- G. The exhibitor shall be prepared to drop the bridle and bit for inspection if the judge so desires. Bridles and bits shall be dropped for inspection by judges in at least one western class and in one English class at each approved show. **For safety reasons, exhibitors must dismount when dropping bridles.**
- H. If the number of entries in any class exceeds the number that can be judged in one group, the class will be judged in two or more sections at show management and/or judge's discretion, and the top horses in each section will be brought back to be judged for the class awards. The number of go-rounds to be held and

the number of horses to be shown in each is at the discretion of show management. Notice of such elimination or go-rounds should be posted at the entry office as soon as determined upon, and it is the responsibility of the exhibitor to ascertain whether and when such elimination as may affect his or her entries will be held. If any entry fails to show in any classes where there are eliminations or go-rounds, the entry will not be eligible to show in the finals.

- I. At the National and World shows, in all classes where each entry performs individually, the order of competition shall be determined by random draw. Horses will work in order of draw. It is the responsibility of the exhibitor to be prepared to work in that order. Draws may be changed to accommodate exhibitors with more than one horse entered in the class. This process is optional at ApHC-approved shows.
- J. In all performance classes, all horses are to be ridden astride (except Ladies' Side Saddle, Pleasure Driving and Heritage).
- K. If only one contestant qualifies in a class, the class shall be considered complete. Should no contestants qualify at show management's discretion, the class may be re-run once in order to attempt to establish a winner.
- L. When an exhibitor competes in a timed event or time trials, each qualifying time shall be announced over the public address system by the show announcer immediately following his or her qualifying runs. Any exhibitor receiving no time due to disqualification shall also be announced over the loud speaker by the show announcer.
- M. All class rules and conditions shall apply to contestants in time trials and/or eliminations. The same exhibitor and/or rider must exhibit the same horse in the eliminations and the class finals.
- N. Futurities, maturities and stakes classes and/or classes open to all breeds may be held at the discretion of show management, and such classes may vary from ApHC-approved or pointed classes as long as they are not held concurrently with ApHC-approved classes. If futurities, maturities or stakes classes are held concurrently with ApHC-approved classes, ApHC rules regarding show, judges, registration, discipline, class conduct, membership, horse, exhibitor and equipment restrictions and limitations shall apply. Futurities, maturities and stakes classes that are not held concurrently with ApHC-approved classes and/or classes open to all breeds shall be conducted at the discretion of show management and by rules and eligibility requirements determined by show management.
- O. When there is no intention for a junior horse to remain snaffle bit class eligible, that horse may be shown in a snaffle bit, hackamore or curb bit at the same show. Once this occurs, the horse is expressly denied the right to compete in snaffle bit/hackamore classes.

715. WESTERN PERFORMANCE

A. EQUIPMENT

1. In all western classes, horses will be shown in a western stock saddle consisting of a horn, seat, pommel, cantle, skirt, fenders and western stirrups. Silver equipment will not count over a good working outfit. Bridle may be either a standard plain or silver headstall with browband, shaped ear, or split ear.
 - a. Stirrups shall not be tied to one another or to the saddle in any manner.
2. References to a bit in western performance classes mean the use of a curb bit that has a solid or broken mouthpiece, has shanks and acts with leverage. All curb bits must be free of mechanical device and should be considered a standard western bit. A description of a legal, standard, western bit includes:
 - a. 8 1/2" (21.59 cm) maximum length shank to be measured as indicated in the diagram on the next page. Shanks may be fixed or loose.
 - b. Concerning mouthpieces, bars must be round, smooth and unwrapped metal of 5/16" to 3/4" (.79 to 1.90 cm) in diameter, measured 1" (2.54 cm) from the cheek. It may be inlaid, but must be smooth or latex wrapped. Nothing may protrude below or above the mouthpiece (bar), such as extensions or prongs (see Illegal Bits). The mouthpiece may

be two or three pieces. A three piece with a connecting ring of 1 1/4" (3.18 cm) or less in diameter, or a connecting flat bar of 3/8" to 3/4" (.95 to 1.90 cm) (measured top to bottom with a maximum length of 2" (60.96 cm), which lies flat in the horse's mouth is acceptable.

- c. The port must be no higher than 3 1/2" (8.89 cm) maximum, with rollers and covers acceptable. Broken mouthpieces, half-breeds, grazing and spades are standard.
- d. When a curb bit is used, a curb strap or curb chain is required, but must meet the approval of the judge, be at least 1/2" (1.27cm) in width and lie flat against the jaw of the horse. Curb straps must be free of barbs, wire and/or twists.
 1. A broken curb strap or chain is not necessarily cause for disqualification.
3. Senior horses (six years old and older) may only be shown in a curb bit, half-breed or spade bit.
4. Junior horses (five years old and younger) may be shown in a snaffle bit, hackamore, curb bit, half-breed or spade bit.
5. Except for hackamore/snaffle bit classes or junior horses shown with an acceptable hackamore/snaffle bit, only one hand may be used on the reins, and the hand must not be changed (except as allowed in trail & GAMING CLASSES GENERAL RULES). The hand is to be around the reins; index finger only between split reins is permitted. The free hand shall not be used to support the rider by being placed on any part of the saddle or horse. Violation of this rule is an automatic disqualification from the class.
6. Standard, leather or woven split reins are acceptable; index finger only between split reins.
7. Whenever this handbook refers to a romal, it means an extension of braided material attached to closed reins. This extension may be carried in the free hand with a 16-inch (40.64 cm) spacing between the reining hand and the free hand holding the romal. When using a romal, the rider's hand shall be around the reins with the wrist kept straight and relaxed, the thumb on top and the fingers closed around the reins. When using the romal, no fingers between the reins are allowed. The free hand may be used to adjust the rider's length of reins while working except in reining and working cow horse (reined work). During the reining and working cow horse (reined work), use of the free hand while holding the romal to alter the tension or length of the reins from the bridle to reining hand is considered to be use of two hands and score of 0 will be applied, with the exception of any place a horse is allowed to be completely stopped during the pattern.
 - a. The romal shall not be used forward of the cinch or to signal or cue the horse in any way. Any infraction of this rule shall result in disqualification.
8. Ideally the free hand should be resting on or in front of the rider's thigh indicating a relaxed, balanced attitude of the body and should be kept free of the horse and equipment.
9. In roping, games and team penning, western type equipment must be used with the exception of bits and mouthpieces. Acceptable western or English bits or mouthpieces may be used if they meet bit specifications outlined in WESTERN EQUIPMENT and ENGLISH EQUIPMENT. Use of a hackamore or a mechanical hackamore with a covered nosepiece or other type of bridle is the option of the exhibitor in roping, games and team penning. No bare metal may be in contact with horse's head.
10. A bit cannot be physically or mechanically altered to increase the severity of its use and may be eliminated at the discretion of the judge. Spring-loaded bits are approved as long as they meet all bit specifications outlined in this handbook. The judge may prohibit the use of bits or equipment he/she may consider severe.
11. An exhibitor may be required by the judge to remove or alter any piece of equipment which, in his opinion, would tend to give a horse or exhibitor an unfair advantage.

SOME ACCEPTABLE CURB CHAINS

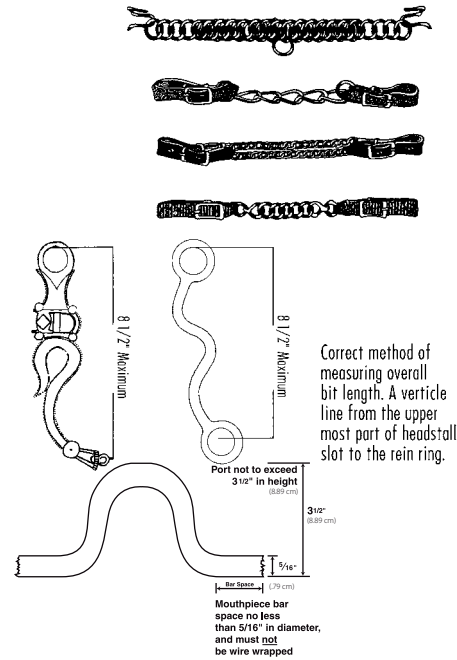

WESTERN BITS

Legal Bit

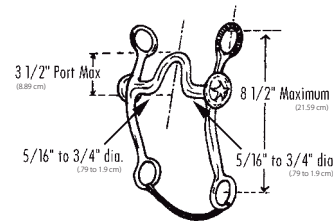

Illegal Bits

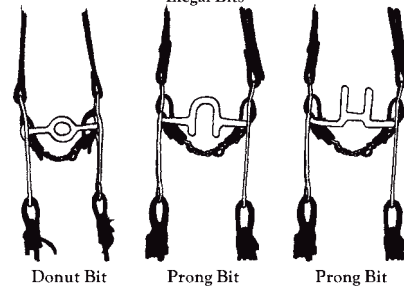

B. OPTIONAL EQUIPMENT

1. Rope or riata; if used, the rope or riata must be coiled and attached to the saddle.
2. Hobbles attached to the saddle.
3. Tapaderos; except in working cow horse where they are not allowed.
4. A standard sliding, rundown or skid boot on the rear fetlocks and splint boots or bell boots on the front legs are optional appointments in the following classes: Team penning, cutting, working cow horse, reining, steer daubing, games and roping. The use of soft leg wraps will be permitted. The use of gel-casts or any other hard-type casts will not be permitted. In the event of injury, the judge may permit a protective bandage.
5. Tie-downs for roping, speed events and team penning. Tie-downs must have covered nosepiece. No bare metal may be in contact with the horse's head.
6. Mechanical hackamore for games, roping and team penning. Mechanical hackamore must have a covered nosepiece. No bare metal may be in contact with the horse's head.
7. Slip or gag bits in roping, games and team penning when used in a humane manner.
8. Running martingales and draw reins for games and team penning only.
9. Spurs; not to be used forward of the cinch.
10. Breast collar.
11. Whips, bats, quirts may be used in the timed or racing events when used in a humane manner.
12. Rain slicker.

C. PROHIBITED EQUIPMENT

1. Protective boots, leg wraps or bandages are prohibited except as provided for in B(4).
2. Wire chin straps, regardless of how padded or covered.
3. Any chin strap narrower than 1/2" (1.27 cm), except in cutting where NCHA rules apply.
4. Nosebands and tie-downs, except as provided for in B(5) and B(6).
5. Jerk lines.
6. Tack collars.
7. Martingales, except as provided in B(8).
8. Any equipment the judge may consider to be inhumane or severe.
9. Slip or gag bits except in roping, games and team penning.
10. Slip or gag bits used in an inhumane manner in roping, games and team penning.
11. Donut and flat polo mouthpieces, bicycle chain (even if wrapped) and mule bits.
12. Any type of tie-down, hackamore or mechanical hackamore with bare metal in contact with the horse's head.

D. SNAFFLE BIT / BOSAL

1. This rule does not refer to a so-called mechanical hackamore. A mechanical hackamore is not considered an acceptable hackamore, except in roping, games and team penning, due to the leverage action of the shanks. Once a horse has been shown in a mechanical hackamore, the horse is ineligible to be shown in hackamore/snaffle bit classes.
2. References to a hackamore/bosal mean the use of a flexible braided rawhide or leather, or rope bosal which can be used in lieu of a snaffle bit, round in shape, the core of which must be rawhide. Absolutely no rigid material or metal will be permitted under the jaws or on the noseband, regardless of how padded or covered. The bosal must be no larger than 3/4" (1.9 cm) in diameter at the cheek, to be measured as indicated in diagram #3. There must be a minimum of two finger spaces (approximately 1 1/2" (3.81 cm))

between the bosal and the nose. The bosal should be properly fitted relative to the horse's size and conformation. Horse hair bosals are not permitted. A mecate is acceptable only when used with a bosal.

3. References to a snaffle bit in western performance classes mean the conventional O-ring, egg-butt or D-ring with a ring no smaller than 2" (5.08 cm) and no larger than 4" (10.16 cm). The inside circumference of the ring must be free of rein, curb or headstall attachments which would provide leverage. The mouthpiece should be round, oval or egg-shaped, smooth, and no mouthpieces can be wrapped in metal. Bit may be inlaid, smooth or latex wrapped. No square-stock steel can be used. The bars must be a minimum of 5/16" (.79 cm) in diameter, measured 1" (2.54 cm) in from the cheek with a gradual decrease to the center of the snaffle.
 - a. The mouthpiece may be two or three pieces. A three-piece with a connecting ring of 1 1/4" (3.18 cm) or less in diameter, or a connecting flat bar of 3/8" to 3/4" (.95 to 1.9 cm) (measured top to bottom with a maximum length of 2" (5.08 cm)) which lies flat in the horse's mouth is acceptable.
 - b. A loose curb strap is optional (leather or nylon only).
4. Standard, leather or woven split reins are mandatory for use with a snaffle bit. Reins must be attached above the curb strap.
5. When a horse is shown with a hackamore/bosal or snaffle bit, the rider must have both hands on both reins. Split reins must be crossed. Rider's hands should be carried near the pommel and not further than four 4" (10.16 cm) out on either side of the saddle horn with very limited movement.
6. A bit cannot be physically or mechanically altered to increase the severity of its use and may be eliminated at the discretion of the judge.
7. A bosal without reins attached and used as a noseband is prohibited. A bosal (noseband) should not be confused with a bosal cinch, which has reins attached and is used as a standard rawhide hackamore.

FIGURE #1

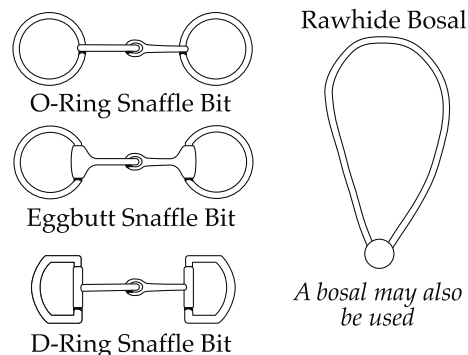

FIGURE #2

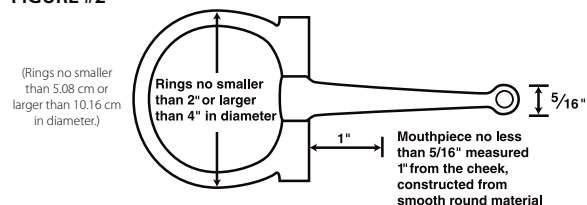
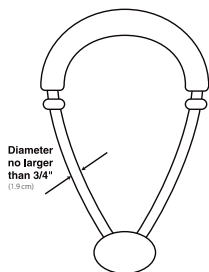

FIGURE #3



E. ATTIRE

1. In all western classes it is mandatory to wear appropriate western attire which includes pants (slacks, trousers, jeans, etc.), long-sleeved shirt with collar (band, standup, tuxedo, etc.), western hat and cowboy boots.
 - a. Chaps are optional at ApHC-approved shows but are mandatory at ApHC-sponsored shows, except as stated in 1:
 1. In leadline, games, roping and team penning classes, chaps are optional as a western requirement at all ApHC shows.
 - b. In all cattle classes the hat must be on the exhibitors head when the exhibitor enters the arena.
 - c. In all game classes, the exhibitor must wear a western hat or ASTM/SEI approved protective headgear. Youth exhibitors 18 years of age and younger are required to wear ASTM/SEI approved helmet with safety harness attached and fastened in all game classes. ASTM/SEI approved protective headgear, while optional for adults, is strongly recommended for use by all exhibitors in all game classes. If the exhibitor wears a hat it must be on the exhibitor's head when he/she enters the arena. (See GAMING CLASS GENERAL RULES.)
 - d. The ApHC strongly encourages all exhibitors to wear protective headgear passing or surpassing current applicable ASTM standards with harness secured while riding anywhere in the competition grounds. It is the responsibility of the exhibitor, or parent or guardian or trainer of the junior exhibitor to see that the headgear worn by the junior exhibitor complies with appropriate safety standards for protective headgear intended for equestrian use, and is properly fitted and in good condition. The ApHC, Show Committee, and Licensed Officials are not responsible for checking headgear worn by the junior exhibitor for compliance with these rules.
 - e. ApHC makes no representation or warranty, express or implied, about any protective headgear, and cautions exhibitors that death or serious injury may result despite wearing such headgear as all equestrian sports involve inherent dangerous risks and as no helmet can protect against all foreseeable injuries.
 - f. If exhibitors choose to wear protective headgear in western classes (western horsemanship, western pleasure, western riding, showmanship, reining, leadline etc.) it is not mandatory that the headgear look like a western hat.
- F. It is recommended in all western classes that the horse's mane, tail and forelock be free of braids. The horse's mane may be banded. However, the presence of braids shall not constitute disqualification.
- G. For requirements on exhibitor numbers, see Rule 711.M.

H. WESTERN GAITS

1. The following terminology shall apply in all Western classes whenever a specific gait is called for:
 - a. The WALK is a natural, flat-footed, four-beat gait. The horse must move straight and true at the walk. The walk must be alert, with a stride of reasonable length in keeping with the size of the horse.

Poor Walk:
This is a horse with an uneven pace and no cadence. He has a robotic appearance and hesitates. He has no flow and may appear intimidated or appear to march.

Average Walk:
This is a horse with a four-beat gait, a level topline and that appears relaxed. This done correctly is average.

Good Walk:
This is a horse with a four-beat gait, level topline and a relaxed appearance yet is bright and attentive. He flows and is soft touching the ground.
 - b. The JOG-TROT is a smooth, ground-covering two-beat diagonal gait. The horse works from one pair of diagonals to the other pair. The jog-trot should be square, balanced and with a straight, forward movement of the feet. Horses walking with their back feet and trotting on the front are not considered to be performing the required gait. When asked to extend the jog, the horse moves out with the same smooth way of going.

Unacceptable Jog:
This is a horse that cannot perform a two-beat gait and appears very uncomfortable in his attempt to accomplish the gait. He does not have any flow or balance in his motion and appears uncomfortable to ride.

Poor Jog:
This is a horse that hesitates or skips a beat in his two-beat motion. He does not keep an even and balanced motion with a level topline. A horse must have a true two-beat gait to be average. This horse appears to shuffle.

Slightly Below-Average Jog:
This is a horse with an average motion but that exhibits negative characteristics in his performance. Some of the negative characteristics may be walking with the hind legs, dragging the rear toes as he jogs, or taking an uneven length of stride with front and rear legs.

Correct or Average Jog:
This is a horse with a two-beat diagonal gait in which the left front and right hind feet touch the ground simultaneously and the right front and left hind do so also. He has a level topline and a relaxed appearance while being shown with light contact, and appears to guide well. This is the standard or average jog.

Good Jog:
This is a horse with an average motion but that exhibits positive characteristics in his performance. Some of these positive characteristics may be balance and self carriage while taking the same length of stride with the front and rear legs.

Very Good Jog:
This is a horse that appears very comfortable to ride, always has a consistent two-beat gait, is guiding well, and has a relaxed and level topline. He may let his hocks drift back into his tail from time to time, or bend his knee a little, but is obviously soft on the ground.

Excellent Jog:

This is a horse whose motions seem effortless and very efficient. He swings his legs, yet touches the ground very softly. This horse is confident, yet still soft in his motion. He is balanced and under control. He is flat with his knee and hock and has some cushion in his pastern. His expression is bright and alert and he exhibits more lift and self-carriage than the “very good jog.”

c. MODERATE EXTENDED JOG

Poor Extended Jog:

This horse never appears to lengthen his stride but just jogs faster. He may also appear to be jarring and rough to ride.

Average Extended Jog:

This is a horse who, when asked to extend, moves up in his pace and appears smooth to sit on.

Good Extended Jog:

This is a horse who, when asked to extend, has an obvious lengthening in his stride with a slight increase in his pace, making him more versatile. This horse is still smooth but appears to have more length with less effort being exerted.

- d. The LOPE is an easy, rhythmical three-beat gait. Horses moving to the left should lope on the left lead. Horses moving to the right should lope on the right lead. Horses traveling at a four-beat gait are not considered to be performing at a proper lope. The horse should lope with a natural stride and appear relaxed and smooth. He should be ridden at a speed that is a natural way of going. Lope should be a balanced, flowing motion with self-carriage.

Unacceptable Lope:

This is a horse that does not have a true three-beat gait. He has no flow, rhythm or balance, appears out of sync, and is obviously not comfortable to ride.

Poor Lope:

This is a horse that may appear to have a three-beat gait but has no lift or self-carriage. This horse shuffles, has no flow, and bobs his head, giving the appearance of exerting a great deal to perform the gait. He also does not appear comfortable to ride.

Slightly Below-average Lope:

This is a horse with an average motion but that exhibits negative characteristics in his performance. Some of these negative characteristics may be head bobbing, not completing the stride with the front leg, and leaving the outside hock well behind the horse’s buttocks. An over-canted horse generally displays these negative characteristics.

Correct or Average Lope:

This is a horse that has a true three-beat gait, with a level topline and very little head and neck motion. The horse has a comfortable motion and is relatively straight (not over-canted). He glides well, and has a relaxed appearance.

Good Lope:

This is a horse with an average motion but that exhibits positive characteristics in his performance. Some of these positive characteristics may be balance and self-carriage, a steady topline, responsiveness to the rider’s aids, and a relaxed appearance.

Very Good Lope:

This is a horse that appears to have more lift and flow than the average horse. He also has a strong but smooth drive from behind. He may bend his knee a little, or allow his off-lead hind or drive leg to

fall behind his tail, yet he still has a level topline, exhibits self-carriage with a relaxed appearance, and appears comfortable to ride.

Excellent Lope:

This horse rounds his back and has a strong, deep stride and a flat swing with his front legs. He swings his legs correct and long yet seems to do it effortlessly. He keeps a very level topline; his hocks don’t drift behind his tail. This horse has a relaxed yet alert and confident appearance. This is a very special horse that is correct, yet soft. This horse has a great degree of lift and self-carriage.

2. TOPLINE: The horse’s head should be carried at an angle that is natural and suitable to the horse’s conformation at all gaits.

Poor Topline:

The horse’s head may be too high or too low. If the horse’s head is consistently higher than his eye level with his withers, his back becomes hollow and he loses his drive from behind. When his head is consistently lower than his ear level with his wither, he becomes heavy on his forehead and has no lift or flow. In both cases the horse loses his self-carriage and appears to struggle.

Average Topline:

A horse who generally displays a level topline with the tip of the ear level with the wither at the lowest point or his eye level with the wither at the highest point, but is inconsistent with his head carriage.

Good Topline:

This horse will display a level topline with the tip of the ear level with the wither at the lowest point or his eye level with the wither at the highest point. He also displays a consistent topline that exhibits self-carriage.

3. BACK-UP

Poor Back-up:

This horse appears resistant or heavy in front. He may gap his mouth, throw his head, or back crooked.

Average or Correct Back-up:

This horse should back straight at least one horse length quietly. This should be done smoothly with light contact and without hesitation.

Good Back-up:

This horse will display balanced and smooth flowing movements, self-carriage, and look to be a pleasure to ride. The horse should back straight at least one horse length quietly and without gapping his mouth. This should be done smoothly with light contact and without hesitation.

4. IMPORTANT: As long as horses with naturally longer strides are performing the gaits correctly, they should not be penalized for passing other horses.

716. REINING

- A. In an open approved reining class, any one of the ten approved ApHC Reining patterns may be used. One of these patterns is to be selected by the judge of the class and used by all contestants in the class. The pattern must be posted one hour prior to the class.
- B. Each exhibitor will perform the required pattern individually and separately. To rein a horse is not only to guide him but also to control his every movement. The best reined horse should be willingly guided or controlled with little or no apparent resistance and dictated to completely. Any movement on his own must be considered a lack of or temporary loss of control and therefore faulted according to severity of deviation. Credit will be given for smoothness, finesse, attitude, quickness, and authority in performing the various maneuvers while using controlled speed.

C. SCORING

1. The scoring will be on a basis of 0 to infinity, with 70 denoting an average performance. The individual maneuvers are scored in 1/2 point increments,

- from a low of -1 1/2 to a high of +1 1/2, with a score of 0 denoting a maneuver that is correct with no degree of difficulty. Scores will be announced after each horse works.
2. Any ties for 1st place will be worked off, using the same pattern and order of go as was used during the event; however, there will not be more than one run off. If a tie occurs after the run off, the entrants will be named co-champions and will evenly split the prize money, but must determine the winner of the awards by a flip of a coin.
 3. Curb chains are permissible provided that:
 - a. they are at least 1/2 inch (1.27 cm) in width;
 - b. they are free of barbs, wire and/or twists;
 - c. they lay flat against the horse's jaw.
 4. The following will result in no score:
 - a. infraction of any state or federal law which exists pertaining to the exhibition, care, and custody of horses within the state or county where an ApHC-approved reining is being held;
 - b. willful abuse of animal in show arena and/or evidence that an act of abuse has occurred prior to or during the exhibition of a horse in competition.
 - c. use of illegal equipment, including wire on bits, bosals or curb chains;
 - d. use of illegal bits, bosals or curb chains;
 - e. use of tack collars, tie-downs or nosebands;
 - f. use of whips or bats;
 - g. use of any attachment which alters the movement of or circulation to the tail;
 - h. failure to provide horse and equipment to the appropriate judge for inspection;
 - i. disrespect or misconduct by the exhibitor.
 - j. the judge(s) may excuse a horse at any time while in the arena for unsafe conditions or improper exhibition pertaining to both the horse/rider.
 5. Excess rein may be straightened at any place a horse is allowed to be completely stopped during a pattern. When using a romal, no finger between the reins is allowed. The free hand may be used to hold the romal, provided it is held at least 16" (40.64 cm) from the reining hand and in a relaxed position. Use of the free hand while holding the romal, to alter the tension or length of the reins from the bridle to the reining hand, is considered to be the use of two hands, and score of 0 will be applied.
 6. The following will result in a score of 0:
 - a. use of more than one finger between reins;
 - b. use of romal other than as outlined in #5;
 - c. failure to complete pattern as written;
 - d. performing the maneuvers other than in specified order;
 - e. the inclusion of maneuvers not specified, including, but not limited to: (1) backing more than 2 strides; (2) turning more than 90 degrees (Exception: a complete stop in the 1st quarter of a circle after a canter departure is not to be considered an inclusion of maneuver; a 2 point break of gait penalty will apply).
 - f. equipment failure that delays completion of pattern;
 - g. balking or refusal of command where pattern is delayed;
 - h. running away or failing to guide where it becomes impossible to discern whether the entry is on pattern;
 - i. jogging in excess of one-half circle or one half the length of the arena while starting a circle, circling or exiting a rollback;
 - j. overspins of more than 1/4 turn;
 - k. fall to the ground by horse or exhibitor.
 7. The following will result in a penalty of five (5) points:
 - a. spurring in front of cinch;
 - b. use of either hand to instill fear or praise;
 - c. holding saddle with either hand;
 - d. blatant disobedience including kicking, biting, bucking, rearing and striking.
 8. The following will result in a 2-point penalty:
 - a. break of gait;
 - b. freezing up in spins or rollbacks;
 - c. on walk in patterns, failure to stop or walk before executing a canter departure;
 - d. on run in patterns, failure to be in a canter prior to reaching first marker.
 - e. if a horse does not completely pass the specified marker before initiating a stop position.
 9. Starting or performing circles or figure eights out of lead will be judged as follows:
 - a. Each time a horse is out of lead, a judge is required to penalize by one point. The penalty for being out of lead is accumulative, and the judge will add 1 penalty point for each 1/4 of the circumference of a circle or any part thereof that a horse is out of lead.
 - b. A judge is required to penalize a horse 1/2 of a point for a delayed change of lead of one stride.
 10. Deduct 1/2 point for starting circle at a jog or exiting rollbacks at a jog up to 2 strides. Jogging beyond two strides but less than 1/2 circle or 1/2 the length of the arena, deduct 2 points.
 11. Deduct 1/2 point for over or under spinning up to 1/8 of a turn; deduct 1 point for over or under spinning up to 1/4 of a turn.
 12. Where a change of lead is specified immediately prior to a run to the end of the pen, failure to change lead will be penalized as follows:
 - a. Failure to change leads by 1 stride, a half point penalty.
 - b. Failure to change leads beyond 1 stride but where lead change is completed prior to the next maneuver, 1 point penalty.
 - c. If the lead is not changed prior to the next maneuver, a 2 point penalty.
 - d. In patterns requiring a run-around, failure to be on the correct lead when rounding the end of the arena will be penalized as follows; for 1/2 the turn or less, 1 point; for more than 1/2 the turn, 2 points.
 13. There will be a half point penalty for failure to remain a minimum of 20 feet (6.09 m) from wall or fence when approaching a stop and/or roll back.
 14. Exhibitor **may be requested** to dismount and drop bridle to the designated judge. If requested, the exhibitor or a designated representative must drop the bridle immediately after the performance. **For safety reasons, exhibitors must dismount when dropping bridles.** The bridle must be checked by the designated judge in the arena or in close proximity to the arena.
 15. No "pattern spotters" will be used.
 16. The judge has the option of awarding a re-ride to any contestant who in the judge's opinion is unable to complete a pattern for reasons that are out of the exhibitor's control. In the instance where a re-ride is warranted in the judge's opinion, the judge should advise the show management as soon as is possible.

17. Judges may not confer as to any penalty or maneuver score prior to submitting a score. If a major penalty (a penalty which results in a no-score, 0 or 5-point penalty) is unclear, a judge will submit his/her score and ask that the score be held, pending a conference or review of the video at the next drag. Should the judges determine, via conference or video replay, that a penalty was incurred, it should be applied. If, however, no penalty occurred, the score will be announced as originally submitted. No judge shall be required to change his/her score following a conference or video replay. Each judge's decision is an individual call and based on individual decision from a conference or video replay. The use of video equipment by the judges is only permissible if the judge has reason to believe that all entries have been videotaped.

D. HACKAMORE/SNAFFLE BIT REINING

1. Open to horses five years old and younger shown with an acceptable hackamore or snaffle bit working in the same manner as prescribed for bridled horses, except must be shown two-handed. No cross entry will be allowed between Hackamore/Snaffle Bit Reining and Junior Reining at the same show.
2. Once a horse is shown in anything other than an acceptable snaffle bit or hackamore/bosal, it is ineligible to compete in Hackamore/Snaffle Bit Reining.

E. REINING PATTERNS

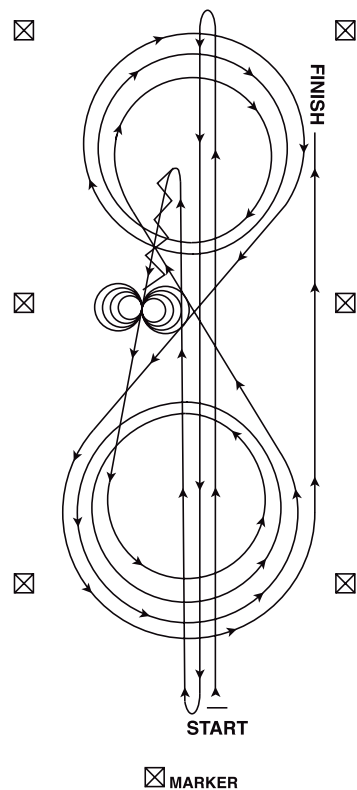

PATTERN 1

1. Run at speed to the far end of the arena past end marker and do a left rollback - no hesitation.
2. Run to opposite end of the arena past end marker and do a right rollback - no hesitation.
3. Run past center of the arena, do a sliding stop, back straight to the center of the arena. Hesitate.
4. Complete four spins to the right.
5. Complete four and a quarter spins to the left, so that horse is facing left wall or fence. Hesitate.
6. Beginning on the left lead, complete three circles to the left. The first circle large and fast - the second circle small and slow - the third circle large and fast. Change leads at the center of the arena.
7. Complete three circles to the right. The first circle large and fast - the second circle small and slow - the third circle large and fast. Change leads at the center of the arena.
8. Begin a large fast circle to the left. Do not close this circle. Run straight up the right side of the arena past center marker and do a sliding stop at least 20 feet (6.09 m) from wall or fence. Hesitate to demonstrate the completion of the pattern.

Exhibitor **may be requested to** dismount and drop bridle to the designated judge.

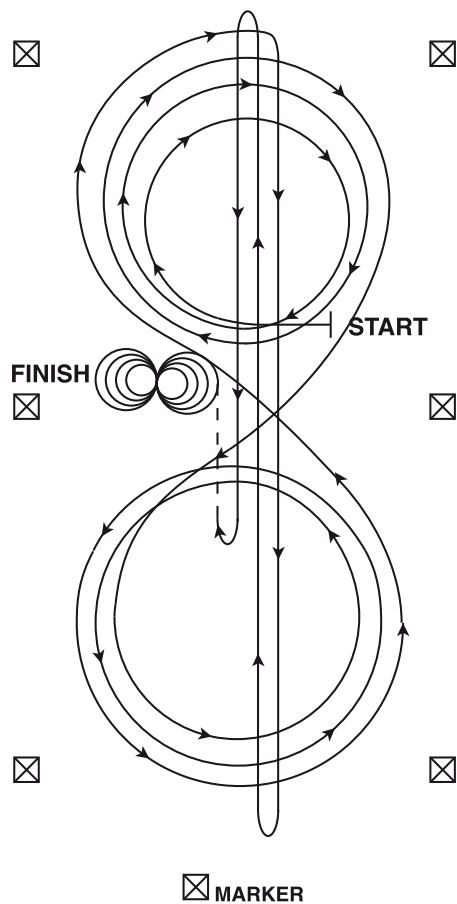

PATTERN 2

Beginning at the center of the arena facing the left wall or fence

1. Beginning on the right lead, complete three circles to the right: the first circle small and slow; the next two circles large and fast. Change leads at the center of the arena.
2. Complete three circles to the left: the first circle small and slow; the next two circles large and fast. Change leads at the center of the arena.
3. Continue around previous circle to the right. At the top of the circle, run down the middle to the far end of the arena past the end marker and do a right rollback - no hesitation.
4. Run up the middle to the opposite end of the arena past the end marker and do a left rollback - no hesitation.
5. Run past the center marker and do a sliding stop. Back up to the center of the arena or at least 10 feet (3.05 m). Hesitate.
6. Complete four spins to the right.
7. Complete four spins to the left. Hesitate to demonstrate the completion of the pattern.

Exhibitor **may be requested** to dismount and drop bridle to the designated judge.

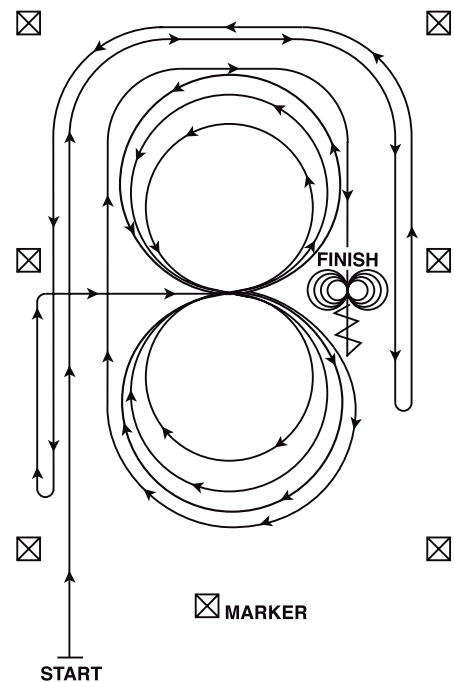

PATTERN 3

1. Beginning and staying at least 20 feet (6.09 millimetre) from the walls or fence, lope straight up the left side of the arena, circle the top end of the arena, run straight down the opposite or right side of the arena past the center marker and do a left rollback - no hesitation.
2. Continue straight up the right side of the arena staying at least twenty feet from the walls or fence, circle back around the top of the arena, run straight down the left side of the arena past the center marker and do a right rollback - no hesitation.
3. Continue up the left side of the arena to the center marker. At the center marker, the horse should be on the right lead. Guide the horse to the center of the arena on the right lead and complete three circles to the right: the first two circles large and fast; the third circle small and slow. Change leads at the center of the arena.
4. Complete three circles to the left: the first two circles large and fast; the third circle small and slow. Change leads in the center of the arena.
5. Begin a large fast circle to the right but do not close this circle. Continue up the left side of the arena staying at least twenty feet from the walls or fence, circle the top of the arena, run straight down the opposite or right side of the arena past the center marker and do a sliding stop. Back up at least 10 feet (3.05 m). Hesitate.
6. Complete four spins to the right.
7. Complete four spins to the left. Hesitate to demonstrate completion of the pattern.

Exhibitor **may be requested** to dismount and drop bridle to the designated judge.

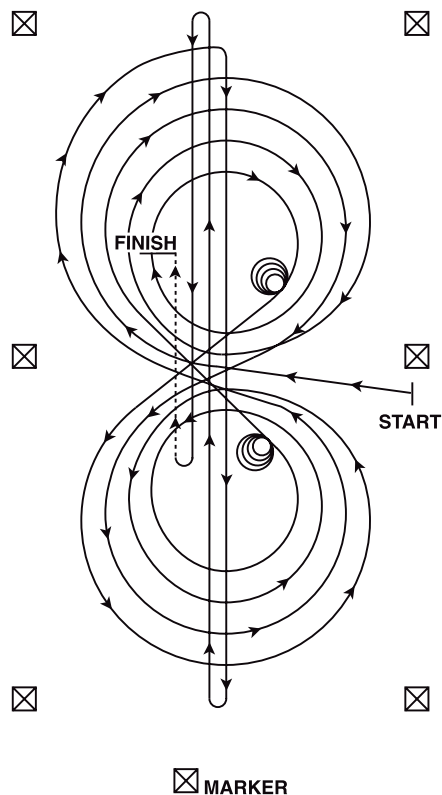

PATTERN 4

Begin at the center of the arena facing left wall or fence.

1. Beginning on right lead, complete three circles to the right: the first two circles large and fast; the third circle small and slow. Stop at the center of the arena.
2. Complete four spins to the right. Hesitate.
3. Beginning on the left lead, complete three circles to the left: the first two circles large and fast; the third circle small and slow. Stop at the center of the arena.
4. Complete four spins to the left. Hesitate.
5. Beginning on the right lead, run a large fast circle to the right, change leads at the center of the arena, run a large fast circle to the left, and change leads at the center of the arena. (Figure 8)
6. Continue around previous circle to the right. At the top of the circle, run down the middle to the far end of the arena past the end marker and do a right rollback - no hesitation.
7. Run up the middle to the opposite end of the arena past the end marker and do a left rollback - no hesitation.
8. Run past the center marker and do a sliding stop. Back up to the center of the arena or at least 10 feet (3.05 m). Hesitate to demonstrate completion of the pattern.

Exhibitor **may be requested to** dismount and drop bridle to the designated judge.

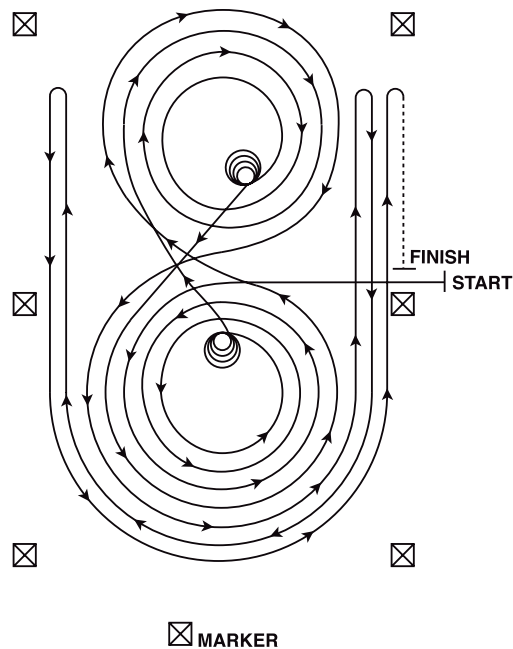

PATTERN 5

Beginning at the center of the arena facing the left wall or fence.

1. Beginning on the left lead, complete three circles to the left: the first two circles large and fast; the third circle small and slow. Stop at the center the arena.
2. Complete four spins to the left. Hesitate.
3. Beginning on the right lead, complete three circles to the right; the first two circles large and fast; the third circle small and slow. Stop at the center of the arena.
4. Complete four spins to the right. Hesitate.
5. Beginning on the left lead, run a large fast circle to the left, change leads at the center of the arena, run a large fast circle to the right, and change leads at the center of the arena. (Figure 8)
6. Continue around previous circle to the left but do not close this circle. Run up the right side of the arena past the center marker and do a right rollback at least 20 feet (6.09 m) from the wall or fence - no hesitation.
7. Continue around previous circle but do not close this circle. Run up the left side of the arena past the center marker and do a left rollback at least 20 feet (6.09 m) from the wall or fence - no hesitation.
8. Continue back around previous circle but do not close this circle. Run up the right side of the arena past the center marker and do a sliding stop at least 20 feet (6.09 m) from the wall or fence. Back up at least 10 feet (3.05 m). Hesitate to demonstrate completion of the pattern.

Exhibitor **may be requested to** dismount and drop bridle to the designated judge.

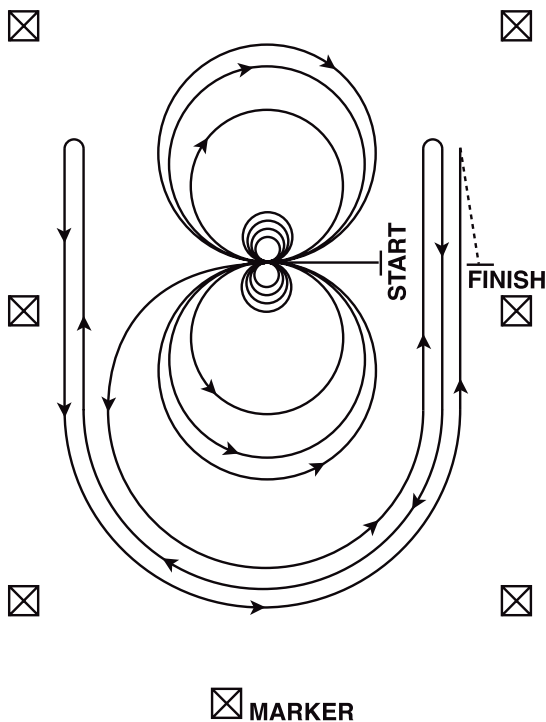

☒ MARKER

PATTERN 6

Beginning at the center of the arena facing the left wall or fence.

1. Complete four spins to the right.
2. Complete four spins to the left. Hesitate.
3. Beginning on the left lead, complete three circles to the left: the first two circles large and fast; the third circle small and slow. Change leads at the center of the arena.
4. Complete three circles to the right: the first two circles large and fast; the third circle small and slow. Change leads at the center of the arena.
5. Begin a large fast circle to the left but do not close this circle. Run up the right side of the arena past the center marker and do a right rollback at least 20 feet (6.09 m) from the wall or fence - no hesitation.
6. Continue back around previous circle but do not close this circle. Run up the left side of the arena past the center marker and do a left rollback at least 20 feet (6.09 m) from the wall or fence - no hesitation.
7. Continue back around previous circle but do not close this circle. Run up the right side of the arena past the center marker and do a sliding stop at least 20 feet (6.09 m) from the wall or fence. Back up at least 10 feet (3.05 m). Hesitate to demonstrate the completion of the pattern.

Exhibitor **may be requested to** dismount and drop bridle to the designated judge.

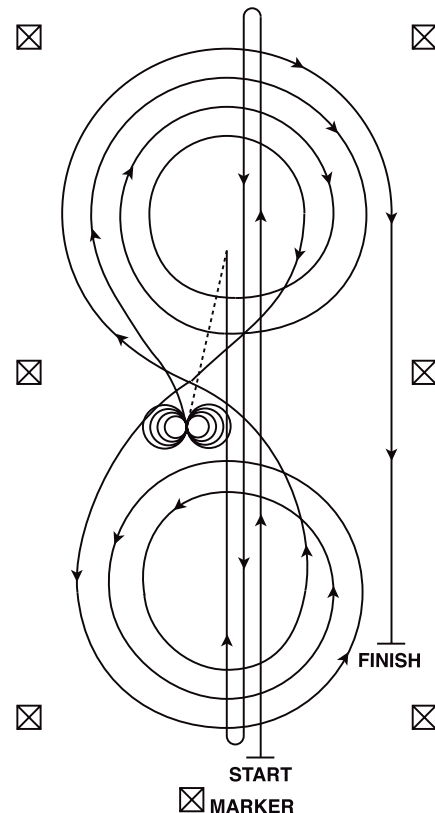

☒ MARKER

PATTERN 7

1. Run at speed to the far end of the arena past end marker and do a left rollback - no hesitation.
2. Run to the opposite end of the arena past end marker and do a right rollback - no hesitation.
3. Run past the center marker, do a sliding stop. Back up to the center of the arena or at least 10 feet (3.05 m). Hesitate.
4. Complete four spins to the right.
5. Complete four and a one-quarter spins to the left so that horse is facing left wall or fence. Hesitate.
6. Beginning on the right lead, complete three circles to the right: the first two circles large and fast, the third circle small and slow. Change leads at the center of the arena.
7. Complete three circles to the left: the first two circles large and fast, the third circle small and slow. Change leads at the center of the arena.
8. Begin a large fast circle to the right but do not close this circle. Run straight down the right side of the arena past the center marker and do a sliding stop at least 20 feet (6.09 m) from the wall or fence. Hesitate to demonstrate completion of the pattern.

Exhibitor **may be requested to** dismount and drop bridle to the designated judge.

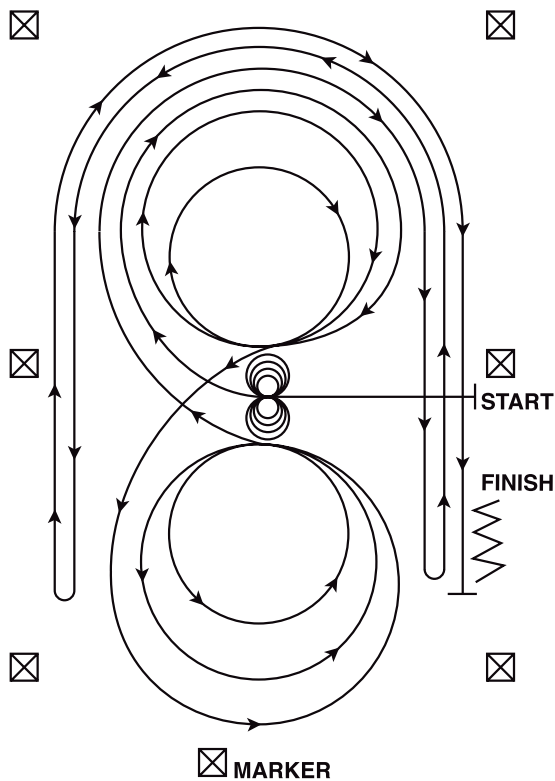

PATTERN 8

Beginning at the center of arena facing the left wall or fence.

1. Complete four spins to the left.
2. Complete four spins to the right. Hesitate.
3. Beginning on the right lead, complete three circles to the right: the first circle large and fast; the second circle small and slow; the third circle large and fast. Change leads at center of the arena.
4. Complete three circles to the left: the first circle large and fast; the second circle small and slow; the third circle large and fast. Change leads at the center of the arena.
5. Begin a large fast circle to the right but do not close this circle. Run straight down the right side of the arena past the center marker and do a left rollback at least 20 feet (6.09 m) from the wall or fence - no hesitation.
6. Continue back around the previous circle but do not close this circle. Run down the left side of the arena past the center marker and do a right rollback at least 20 feet (6.09 m) from the wall or fence - no hesitation.
7. Continue back around the previous circle but do not close this circle. Run down the right side of the arena past the center marker and do a sliding stop at least 20 feet (6.09 m) from the wall or fence. Back up at least 10 feet (3.05 m). Hesitate to demonstrate completion of the pattern.

Exhibitor **may be requested to** dismount and drop bridle to the designated judge.

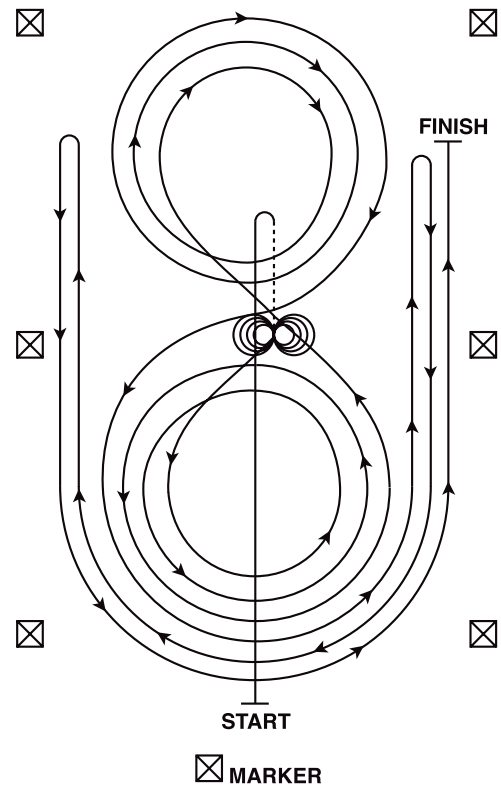

PATTERN 9

1. Run past the center marker and do a sliding stop. Back up to center of the arena or at least 10 feet (3.05 m). Hesitate.
2. Complete four spins to the right.
3. Complete four and one-quarter spins to the left so that horse is facing the left wall or fence. Hesitate.
4. Beginning on the left lead, complete three circles to the left: the first circle small and slow; the next two circles large and fast. Change leads at the center of the arena.
5. Complete three circles to the right: the first circle small and slow; the next two circles large and fast. Change leads at the center of the arena.
6. Begin a large fast circle to the left but do not close this circle. Run up the right side of the arena past the center marker and do a right rollback at least 20 feet (6.09 m) from the wall or fence - no hesitation.
7. Continue back around the previous circle but do not close this circle. Run up the left side of the arena past the center marker and do a left rollback at least 20 feet (6.09 m) from the wall or fence - no hesitation.
8. Continue back around previous circle but do not close this circle. Run up right side of the arena past the center marker and do a sliding stop at least 20 feet (6.09 m) from the wall or fence. Hesitate to demonstrate completion of the pattern.

Exhibitor **may be requested to** dismount and drop bridle to the designated judge.

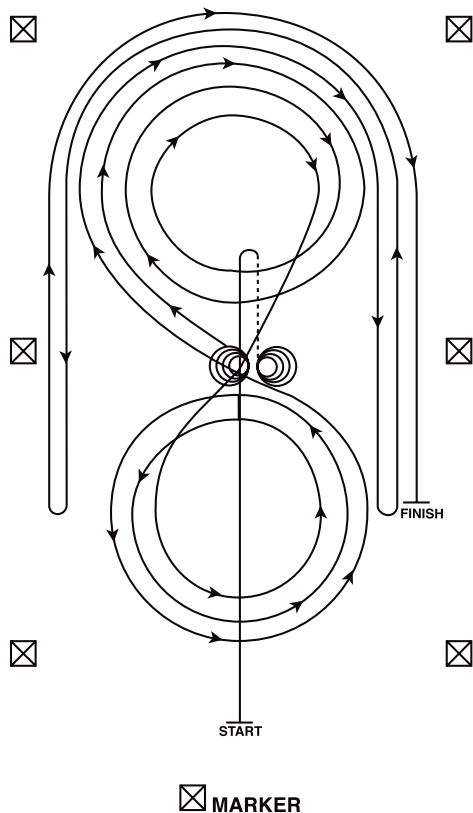

☒ MARKER

PATTERN 10

1. Run past the center marker and do a sliding stop. Back up to the center of the arena or at least 10 feet (3.05 m). Hesitate.
2. Complete four spins to the right.
3. Complete four and one-quarter spins to the left so that the horse is facing the left wall or fence. Hesitate.
4. Beginning on the right lead, complete three circles to the right: the first two circles large and fast, the third circle small and slow. Change leads at the center of the arena.
5. Complete three circles to the left: the first circle small and slow, the next two circles large and fast. Change leads at the center of the arena.
6. Begin a large fast circle to the right but do not close this circle. Run down the right side of the arena past the marker and do a left roll back at least 20 feet (6.09 m) from the wall or fence - no hesitation.
7. Continue back around the previous circle but do not close this circle. Run down the left side of the arena past the center and do a right roll back at least 20 feet (6.09 m) from the wall or fence - no hesitation.
8. Continue back around previous circle but do not close this circle. Run down the right side of the arena past the center marker and do a sliding stop at least 20 feet (6.09 m) from the wall or fence. Hesitate to demonstrate completion of pattern.

Exhibitor **may be requested to** dismount and drop bridle to the designated judge.

F. FREESTYLE REINING

1. The following rules apply only to classes held at an ApHC-sponsored show.
 2. Reining maneuvers originated from moves that a cow horse must use in performing its duties and have been refined to the high level of competition that exists today. Freestyle Reining not only provides an opportunity to use these maneuvers creatively, but also to expand them to music by means of choreography. Exhibitors are encouraged to use musical scores which permit them to show the athletic ability of the horse in a crowd appealing way. Musical selections are chosen by the exhibitor and may be combined and edited to fit the Freestyle pattern and time requirements.
 3. Time Limit: Maximum of 4 minutes including any introductions. The time limit will be from the beginning of the music or from the beginning of the introduction (whichever is first) and will end with the music. Failure to perform all the required maneuvers or failure to complete the performance within the time limit will result in a score of 0.
 4. Required maneuvers will be defined as follows:
 - a. A minimum of 4 consecutive spins to the right.
 - b. A minimum of 4 consecutive spins to the left.
 - c. A minimum of 3 stops.
 - d. A minimum of 1 lead change at the canter from right to left.
 - e. A minimum of 1 lead change at the canter from left to right.
 - f. Additional repetitions of required maneuvers are appropriate, but will only add or subtract from the existing scores already given for the required maneuvers, not as additional scores. Additional maneuvers such as rollbacks, backups, speed variations and non classical reining maneuvers such as half pass and side pass are appropriate in Freestyle and shall be given appropriate credit.
 5. Validating required maneuvers will not be the responsibility of the judges. At least one scribe will be used to verify the required maneuvers for each horse as they are completed in the pattern.
 6. Exhibitors will only be judged astride.
 7. Exhibitors are allowed to use two hands (as well as one or no hands) and any bit approved by the ApHC rulebook, including snaffle bits and bosals approved for use in the Snaffle Bit or Hackamore classes.
 8. Costumes: Permitted but not required. Emphasis is placed on performing the reining maneuvers to music.
 9. Show Management will reserve the right to rule on music or dress which may be inappropriate or offensive to the spirit and nature of the show. Show management may also determine the use of special lighting. Show management reserves the right to rule on props in addition to music and dress.
 10. Judging of Freestyle Reining: Each exhibitor will be judged 0 to infinity, with 70 denoting an average performance.
 - a. Three judges will judge reining maneuvers (technical merit).
 - b. Two judges will judge musical and costume choreography (artistic impression).
 - c. One judge will assign a score based upon the level of the applause meter.
- Scores will be weighted according to the following formula; Technical merit = 75%, artistic impression = 20% and applause meter = 5%.
11. Ties for first place will be run-off. Ties for any other place will be broken by a tie-breaking judge, who must be one of the technical merit judges.
 12. Props are permitted but at no time may they hinder the judges' view of the horse. The use of props will not add to the score. Props may not include open flame or live animals, (with the exception of additional horses being allowed in the arena).
 13. This class is open to horses of any age who are eligible to show in ApHC-sponsored shows.

717. WESTERN RIDING

- A. Western Riding is an event where the horse is judged on quality of gaits, lead changes at the lope, response to the rider, manners, and disposition. The horse should perform with reasonable speed, and be sensible, well-mannered, free and easy moving.
- B. Credit shall be given for an emphasis placed on smoothness, even cadence of gaits (i.e., starting and finishing the pattern with the same cadence), and the horse's ability to change lead precisely, easily, and simultaneously both hind and front at the center point between markers. The horse should have a relaxed head carriage showing response to the rider's hands, with a moderate flexion at the poll. Horses may be ridden with light contact or on reasonably loose rein. The horse should cross the log both at the jog and the lope without breaking gait or radically changing stride.
- C. The judge will select one of the five patterns to be performed. The judge is responsible for the pattern being correctly set.
- D. For the pattern:
1. The eight small circles represent markers (cones are recommended). These should be separated by a uniform measured distance of not less than 30 nor more than 50 feet (9.15 nor more than 15.24 m) on the side with five markers (see diagram). In Pattern 1, the three markers on the opposite side should be set adjacent to the appropriate markers. It is recommended that markers be set a minimum of 15 feet (4.57 m) from the fence and with 50 to 80 feet (15.24 to 24.39 m) width in the pattern, as the arena permits.
 2. The rectangle represents an obstacle (one small log, minimum of 8 feet (2.44 m) long recommended) just high enough to break the horse's stride.
 3. The long serpentine line indicates the direction to travel and the gaits at which the horse is to move. The dotted line (...) indicates walk. The dash line (- - -) jog, and the solid line (_____) lope. The recommended lead changing point is equal to 1/2 stride length before or after the center point between the markers. The recommended lead changing point is shaded in all pattern diagrams.
- E. Scoring will be on a basis of 0 to 100, with 70 denoting an average performance.
1. Scoring guidelines to be considered: points will be added or subtracted from the maneuvers on the following basis, ranging from + 11/2 point to - 11/2 point: +11/2 excellent; +1 very good; +1/2 good; 0 average; -1/2 poor; -1 very poor; - 11/2 extremely poor.
- F. An exhibitor will be penalized:
1. Five (5) points
 - a. Failure to change leads (including cross-cantering)
(Note: failures to change, including cross-cantering, at two consecutive change areas would result in 10 penalty points.)
 - b. Blatant disobedience such as kicking out, biting, bucking, rearing
 - c. Use of free hand to instill fear or praise.
 2. Three (3) points
 - a. Not performing the specific gait (jog or lope) or not stopping when called for in the pattern, within 10 feet (3.05 m) of the designated area
 - b. Breaking gait at lope
 - c. Simple lead change
 - d. Out of lead prior to the designated change from the cone to the previous change area or out of lead after the designated change from the cone to the next designated change area.
 - e. Additional lead changes anywhere in pattern (except when correcting an extra change or incorrect lead).
 - f. In patterns one and three, failure to start the lope within 30 feet (9.15 m) after crossing the log at the jog.
 - g. Break of gait at walk or jog for two or more strides.
3. One (1) point:
 - a. Break of gait at walk or jog up to two strides.
 - b. Hitting or rolling log.
 - c. Out of lead for more than one stride to the cone.
 - d. Splitting the log (log between the two front or two hind feet) at a lope.
 4. One half (1/2) point:
 - a. Tick or light touch of log.
 - b. Hind legs skipping or coming together during lead change.
 - c. Out of lead from 1/2 to 1 stride.
 5. Disqualified - 0 score (cannot place)
 - a. Fall to ground by horse or exhibitor.
 - b. Illegal equipment.
 - c. Willful abuse.
 - d. Off course - which includes an incomplete pattern, incorrect order of maneuvers or passing on wrong side of marker.
 - e. Knocking over markers.
 - f. Completely missing log.
 - g. Major refusal - stop and back 2 strides or 4 steps with front legs.
 - h. Major disobedience or schooling.
 - i. Failure to start lope prior to end cone in pattern #1.
 - j. Performance of four (4) or more simple lead changes and/or failures to change leads.
 - k. Overturns of more than 1/4 turn.
 6. The following characteristics are considered as faults and should be judged accordingly:
 - a. Opening mouth excessively or raising head on maneuvers.
 - b. Anticipating signals or early lead changes.
 - c. Stumbling.
 - d. Losing stirrup or holding on.
 - e. Any unnecessary aid given by the exhibitor, such as; unnecessary talking, petting, spurring, quirted or jerking of the reins.
 7. Credits:
 - a. Change of leads, hind and front simultaneously.
 - b. Changes at designated point.
 - c. Accurate and smooth pattern.
 - d. Even pace throughout.
 - e. Easy to guide and control with rein and leg.
 - f. Manners and disposition.
 - g. Conformation and fitness.

G. WESTERN RIDING PATTERNS

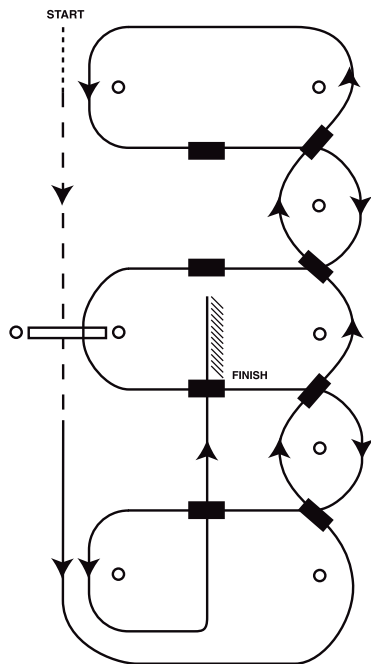

WESTERN RIDING PATTERN 1

1. Walk and jog over log
2. Transition to left and lope around end
3. First line change
4. Second line change
5. Third line change
6. Fourth line change and lope around the end of arena
7. First crossing change
8. Second crossing change
9. Lope over log
10. Third crossing change
11. Fourth crossing change
12. Lope up the center, stop and back

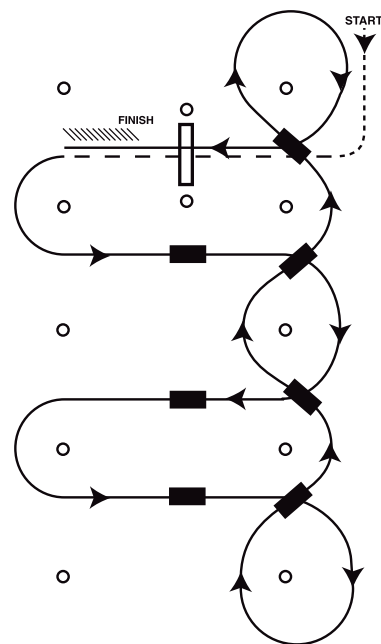

WESTERN RIDING PATTERN 2

1. Walk, transition to jog, jog over log
2. Transition to left lead
3. First crossing change
4. Second crossing change
5. Third crossing change
6. Circle and first line change
7. Second line change
8. Third line change
9. Fourth line change and circle
10. Lope over log
11. Lope, stop and back

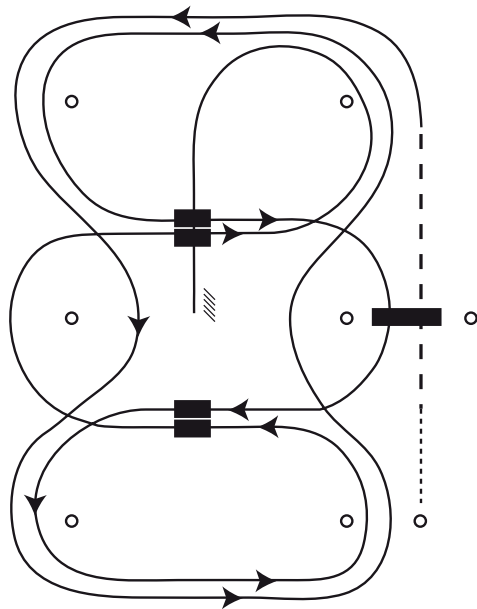

Recommended for small arenas.



WESTERN RIDING PATTERN 5

1. Walk, transition to jog, jog over log
2. Transition to the lope, on the left lead
3. First line change
4. Second line change
5. Third line change
6. Fourth line change
7. First crossing change
8. Lope over log
9. Second crossing change
10. Third crossing change
11. Fourth crossing change
12. Lope, stop & back

718. WESTERN PLEASURE

- A. Horses are to be shown at a walk, jog, and lope on a reasonably loose rein without undue restraint. Horses must work both ways of the ring at all three gaits to demonstrate their ability with different leads. Horses are required to back easily and stand quietly. Gaits should be asked for in the following manner: "walk", "jog", "extended jog" (at least one direction), and "lope". An extended jog (at least one direction) is required in all classes, except in walk-trot, novice youth, 12 & under and 13 & under youth classes. However, it is acceptable for a judge to ask for an extended jog in walk-trot, novice youth, 12 & under and 13 & under youth classes if so desired. See WESTERN GAITS.
- B. A good pleasure horse has a stride of reasonable length in keeping with his conformation. He has enough cushion to his pastern to give the exhibitor a pleasant, smooth ride. He carries his head in a natural position, not high, overflexed at the poll or low with the nose out. The horse should be relaxed but alert and ready to respond to the exhibitor's commands without excessive cueing. When asked to extend the jog, the horse moves out with the same smooth way of going.
- C. To be judged on performance, manners, conformation, quality and substance.
- D. Judge may ask for additional work of the same nature from any horse. He is not to ask for work other than what is listed above.
- E. Exhibitor shall not be required to dismount except in the event judge wishes to check equipment. Horses and equipment are subject to examination by the judge(s).
- F. Faults (except in Novice Non-Pro or Youth), will be scored according to severity but are not necessarily cause for disqualification:
 1. Missed lead or break of gait shall be penalized according to severity at judge's discretion.
 2. Any loss of forward motion may be penalized up to three places on judge's card or be placed last in a small class.
 3. Refusal to back shall result in a penalty or disqualification at the judge's discretion.
 4. When a transition is called for, the exhibitor should take the requested gait within five (5) seconds. Failure to do so may, at the judge's discretion, result in a penalty.
 5. Excessive speed (any gait).
 6. Excessive slowness in any gait, loss of forward momentum.
 7. Touching horse or saddle with either hand.
 8. Horse's head carried too low or too high.
 9. Overflexing or straining neck in head carriage so the nose is carried behind the vertical for five or less strides.
 10. Nosing out.
 11. Opening mouth excessively.
 12. Stumbling.
 13. A horse that appears sullen, dull, lethargic, emaciated, drawn or overly tired. (May also be cause for disqualification per Rule 30).
 14. Quick, choppy or short-strided.
 15. Reins draped to the point that light contact is not maintained.
 16. Overly canted at the lope. (when the outside hind foot is further to the inside of the arena than the inside front foot.)
- G. The following will be cause for automatic disqualification, except in novice non-pro or youth classes, in which faults will be scored according to severity:
 1. Changing hands on reins.
 2. More than one finger between reins.
 3. Over-flexing or straining neck in head carriage so the nose is carried behind the vertical consistently for more than five strides.

H. TWO-YEAR-OLD SNAFFLE BIT WESTERN PLEASURE

1. Open to 2-year-old colts, fillies or geldings.
2. To maintain eligibility the two-year-old year for two-year-old events, entry

into other performance events is prohibited with the following exceptions: Two-year-olds may cross enter two-year-old snaffle bit hunter under saddle, pleasure driving, men's heritage, ladies' heritage, 1st year green pleasure classes and snaffle bit/bosal futurities. A two-year-old may cross-enter junior western pleasure and/or junior hunter under saddle after May 20 only if there are no other entries in their respective two-year-old class and only if the two-year-old class precedes the junior class(es) on the class list.

- a. In order to maintain two-year-old eligibility, horses may only be shown in equipment acceptable for use in two-year-old classes regardless of the class in which they are exhibited.
3. Once a horse has been shown in anything other than an acceptable snaffle bit or bosal, it is no longer eligible to be shown in snaffle bit/hackamore classes. Once a horse has been shown in a mechanical hackamore, the horse is ineligible to be shown in hackamore/snaffle bit classes.
 - a. Horses shown in two-year-old snaffle bit hunter under saddle classes in acceptable equipment remain eligible to be shown in two-year-old snaffle bit western pleasure.
4. A 2-year-old cannot compete in any ApHC-approved performance event prior to May 20th of the current year. National points will not be accumulated for year-end high-point awards. Points will be accrued for horse's record only.
5. Equipment. (see WESTERN PERFORMANCE and ATTIRE), see rule 715.D for specifications.
6. Judging

- a. Entries must be shown with both hands on reins, maintaining light contact with horse's mouth. The exhibitor's hands should be carried near the pommel and not further than 4" (10.16 cm) out on either side of the saddle horn. Hands must be steady with very limited movements, and hands must be visible at all times.
- b. Show management shall provide a minimum five-minute warm-up, not to exceed 10 minutes, in the show arena. Horses must be ridden during the warm-up period with the same equipment used during the class.
- c. Headstalls must be dropped prior to judge's final placing. If horse's mouth or nose shows broken rawness or bleeding, the horse will be eliminated from competition.

I. THREE-YEAR-OLD SNAFFLE BIT WESTERN PLEASURE

1. Open to three-year-old stallions, mares and geldings who have been shown in an acceptable snaffle bit or hackamore/bosal only. Horses shown in any other bit are ineligible.
2. All three-year-old horses may be allowed to enter any open, youth or non-pro class ridden two-handed in an acceptable snaffle bit or hackamore/bosal.
3. Equipment. (see WESTERN PERFORMANCE), see rule 715.D for specifications.
4. Judging is same as Two-Year-Old Snaffle Bit Western Pleasure.
5. Once a horse is shown in anything other than an acceptable snaffle bit or hackamore/bosal, it is ineligible to compete in snaffle bit classes. Once a horse has been shown in a mechanical hackamore, the horse is ineligible to be shown in hackamore/snaffle bit classes.
 - a. Horses shown in three-year-old snaffle bit hunter under saddle classes in acceptable equipment remain eligible to be shown in three-year-old snaffle bit western pleasure.
6. Show management shall provide a minimum five-minute warm-up, not to exceed 10 minutes, in the show arena. Horses must be ridden during the warm-up period with the same equipment used during the class.
- J. When a horse is shown with a hackamore/bosal or snaffle bit, the rider must have both hands on both reins. Split reins must be crossed. Rider's hands should be carried near the pommel and not further than 4" (10.16 cm) out on either side of the saddle horn with very limited movement.

ACCEPTABLE

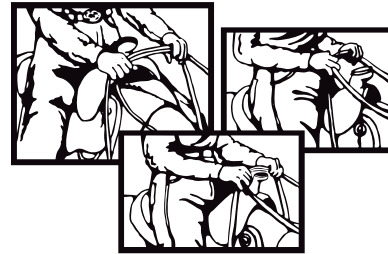

K. NOT ACCEPTABLE, SEVERELY PENALIZED

1. Not acceptable, severely penalized; reins too tight—straight line from bit to hands.
2. Not acceptable, severely penalized; reins too loose.
3. Acceptable.

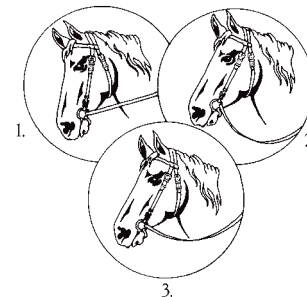

L. JUNIOR WESTERN PLEASURE

1. Open to all horses five years old and under.
 - a. Two-year-old snaffle bit/bosal horses are eligible to be shown in Junior Western Pleasure and/or Junior Hunter Under Saddle after May 20 only if there are no other entries in their respective two-year-old class and if the two-year-old class precedes the junior class(es) on the class list.
2. When there is no intention for a junior horse to remain snaffle bit class eligible, that horse may be shown in a snaffle bit, hackamore or curb bit at the same show. Once this horse has been shown in anything other than an acceptable snaffle-bit or bosal, the horse is expressly denied the right to compete in snaffle bit/hackamore classes.

M. SENIOR WESTERN PLEASURE

Open to all horses six years old and older.

N. LADIES' WESTERN PLEASURE & MEN'S WESTERN PLEASURE

Open to all horses except Two-Year-Old Snaffle Bit/Bosal horses. Three-Year-Old Snaffle Bit/Bosal horses are eligible.

O. WALK-TROT WESTERN PLEASURE

1. Except as noted below, general western pleasure rules apply (except that the exhibitors will not be asked to lope but may be asked to extend the jog).
2. If the horse breaks into a lope for more than three consecutive strides, it shall be disqualified.
3. See YOUTH WALK-TROT DIVISION, rule 807 for rules regarding youth eligibility for youth walk-trot classes.
4. See NON-PRO WALK-TROT DIVISION, rule 901.E for rules regarding non-pro eligibility for non-pro walk-trot classes.

719. YEARLING LONGE LINE

- A. Open to yearling fillies, colts and geldings that are eligible to show at ApHC-approved shows.
- B. The purpose of showing a yearling on a longe line is to demonstrate that the horse has the movement, manners, expression, attitude and conformation to become competitive under saddle. Therefore, the purpose of this class is to reward:
- Quality of movement, b) Manners, Expression and Attitude and c) Conformation suitable to future performance. The horse should be judged with its suitability as a future performer under saddle in mind. This class should define what it means to be a “western pleasure prospect” or “hunter under saddle prospect”. Because these are yearlings, they are not expected to demonstrate the behavior or quality of a finished show horse, but only that performance necessary for a reasonable presentation to the judge.
- C. Equipment: Horses are to be shown in a halter, regular or show type is acceptable.
- For the longeing demonstration, the only attachment allowed to the halter is the longe line. The longe line (including chain and snap) may not exceed 30 feet (9.15 m) in length with a chain or snap attached to the halter. The longe line must hang free from the halter without touching any part of the horse. It is permissible to use a longe whip however, disqualification will occur if the exhibitor blatantly strikes the horse with the whip; to cause forward or lateral movement at any time during the longeing demonstration. No other equipment is allowed on the horse during the class, except as noted in C.2. below. Mechanical or retractable longe lines are not allowed.
 - For conformation inspection, a lead shank may be exchanged for the longe line prior to the longeing demonstration. During the conformation inspection only, the lead shank or longe line chain can be used under the chin, over the nose or hanging from the halter.
 - Exhibitors are not to be penalized for using regular halters and plain longe lines, nor are they to be rewarded for using show halters and show longe lines. Only movement, manners, expression, way of going and conformation are being judged. The type of equipment used is not to be a consideration in placing the horse as long as the equipment meets the requirements stated above.
- D. Attire: The type of attire worn by the exhibitor is not to be a consideration in placing the horse as long as the attire meets the requirements stated here.
- Conventional western attire is mandatory when exhibiting a western pleasure prospect.
 - Conventional English attire or Hunter in Hand attire (to be worn with paddock boots only – no tennis shoes are allowed) is suggested when exhibiting a hunter under saddle prospect. Refer to ENGLISH PERFORMANCE for conventional English attire rules and to HUNTER IN HAND for appropriate attire. When exhibiting a hunter under saddle prospect, the horse may be braided and shown at the walk, long trot and canter.
- E. Gaits: To be judged according to ApHC rules for gaits for Western pleasure and hunter under saddle classes.
- F. Class Format: The class will consist of two parts: 1) a longeing demonstration lasting one and one-half minutes (90 seconds) and 2) a conformation inspection.
- The longeing demonstration will begin at the sound of a whistle or other audible indicator when the horse has reached the perimeter of its circle. Time will not begin until the horse reaches this perimeter. When the starting signal is given, the exhibitor will be allowed one and one-half minutes (90 seconds) to present the horse at all three gaits in both directions. At the end of the 90 seconds, a signal will be given to signify the end of the demonstration. Show management has the option of adding a “half-way” signal.
 - The conformation inspection will occur prior to the longeing demonstration. Each entry will be walked into the arena and will pause for evaluation

individually. Entries will then trot off straight and around a cone and then move in the arena under the direction of the ring steward. Horses showing evidence of lameness during this portion of the class shall be excused from the class at this time. An example of the conformation pattern is illustrated in Figure #1.

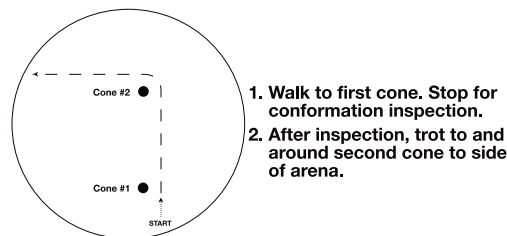

Figure #1

- It is recommended that show management take into account the number of horses in the class and adjust procedures accordingly to ensure that each horse is given equal consideration.
- G. Judging:
- Each horse is to be inspected by the judge on conformation, proper equipment and attire and for evidence of abuse, inhumane treatment, lameness and/or other violation of ApHC rules. If a horse's nose, mouth or jaw area shows broken skin, rawness or bleeding, the horse will be eliminated from competition. Horses will not be allowed to show if entrants do not conform to equipment and attire rules or if there is evidence of abuse or inhumane treatment.
 - It is mandatory that the horses “trot off” during the conformation inspection prior to the longeing demonstration. Horses that show evidence of lameness as defined by ApHC rules shall be excused prior to the longeing demonstration.
 - Judge(s) will be outside of the longeing circle. The exhibitor will enter the arena and await the audible start signal. The start signal may be a bell, whistle or announcement. When the signal is given, the exhibitor will be allowed 11/2 minutes to present the horse. At the end of the 11/2 minutes the signal will be given again to signify the end of the demonstration. Show management has the option of adding a “half-way” signal if they choose.
 - The horse will be scored at all three gaits in both directions. Western pleasure prospects are to be shown at the walk, jog and lope. Hunter under saddle prospects are to be shown at the walk, trot and canter. Any horse that does not exhibit these gaits in each direction will be disqualified from the class. The turnaround at the walk to take the second direction of the pattern shall be considered as fulfilling the walking requirement of the second direction portion of the scoring format. Additionally, the judge shall immediately excuse any horse who exhibits obvious lameness at any time during the class. The exhibitor may begin work in the direction of their choice (counter or clockwise).
 - At the end of the 11/2 minutes, a signal will be given and the exhibitor shall at the request of show management either 1) retire from the longeing area to the far end of the ring or 2) leave the ring and wait nearby for final class placings. If the horses remain in the ring, they are to stand quietly on the wall while the other exhibitors present their horses.

6. The horses are judged, suitable to their purpose by the following scoring system:
 - a. movement (80 points),
 - b. manners/expression/attitude (10 points),
 - c. conformation (20 points) and
 - d. use of circle (3 points)

Judges should evaluate the movement of the horse as defined in ApHC rules for gaits.

7. If the horse plays on the longe line, it shall not count against the horse. The judge will, however, penalize the horse for excessive bucking or running off, stumbling or displaying attitudes that are uncomplimentary to pleasure horses. Fall of horse shall constitute disqualification.
8. Exhibitors are encouraged to exhibit their horse making full use of the 25-foot-radius (7.62 m) longeing circle, as they will be scored on this.
9. The conformation inspection will occur as the horse is walked into the arena prior to the longeing demonstration at which time the judge will evaluate the horse for conformation suitable for future under-saddle performance. The judge may not discriminate for or against muscling, but rather look for a total picture, emphasizing balance, structural correctness and athletic capability.

H. Scoring: The official longe line scoring sheet provided by the ApHC must be used. The horse with the highest score is the winner, with the maximum possible total score of 113 with 56 being average. The judge shall have the sole discretion to use their own personal preference in order to break any ties that occur as a result of the scoring system.

1. Movement will count for 80 points of the total score. Judges are to evaluate movement based upon WESTERN GAIT descriptions for western pleasure prospects and ENGLISH GAIT descriptions for hunter under saddle prospects. This class should be looked upon as a class that defines what it means to be a "western pleasure prospect" or "hunter under saddle prospect" suitable to become a future performer under saddle. Therefore, attitudes and attributes that contribute to becoming a future performer will be rewarded within the gait scores. Higher gait scores will reflect: 1) Above-average to exceptional manners, expression, alertness, responsiveness and pleasant attitude, 2) Above-average to exceptionally smooth transitions between gaits, 3) Above-average to excellent cadence and consistency at all three gaits.

- a. Walk: The walk will be scored on a scale of 0-4 in each direction with 2 being average. The horse must walk long enough for the judge to have sufficient time to evaluate and score the walk. The walk to take the second direction during the demonstration may count for the second walk score on the score sheet.
- b. Jog or Trot: The jog or trot will be scored on a scale of 0-16 in each direction with 8 being average. Using a 25 foot (7.62 m) radius, the horse should jog or trot a minimum of one half of the circle in both directions.
- c. Lope or Canter: The lope or canter will be scored on a scale of 0-20 in each direction with 10 being average. Using a 25 foot (7.62 m) radius, the horse should lope or canter a minimum of one full circle in both directions. Any entry that fails to demonstrate the correct lead for one full circle will not place over another entry that has demonstrated the correct lead in its entirety.
- d. Stumbling at the walk, jog/trot and/or lope/canter should be reflected in lower gait scores.
- e. Circle Scores: A 25 foot (7.62 m) radius is the appropriate size of circle in which to show a longe line horse. It is the judges' responsibility to evaluate the circles and incorporate use of the circle in the gait scores based on the following scale.

1. +3 points (Good to Excellent use of circle): Horse consistently stays on the perimeter of the circle with slight looseness in the line. Horse turns around on the circle perimeter.
2. +2 points (Average use of the circle): Horse is only slightly inconsistent in using the 25 foot (7.62 m) radius of the circle.
3. +1 point (Adequate use of the circle): Horse is shown in a circle radius of less than 25 feet (7.62 m) .
4. 0 points (General use of the circle): Potentially dangerous slack in the line. Horse pulls exhibitor out of the circle.

2. Use of Circle: Consideration will be given to how well or how poorly the horse/exhibitor team uses the 25 foot (7.62 m) radius of the longeing circle. A separate box on the scoresheet is available to indicate an overall score from 0-3 points. In addition, scores for all gaits in both directions should reflect positive, consistent use of the 25 foot (7.62 m) radius of the circle. Credit will be given for full, extended use of the circle on a slightly loose line. Lack of full use of the circle should be reflected in lower gait scores.
3. Manners/Expression/Attitude will count for 0-10 points of the total score with 5 being average. Horses will be penalized for obvious signs of overwork and sourness such as ear-pinning, head-throwing, striking, tail-wringing, or a dull, lethargic manner of going. They will also be penalized for dangerous behavior such as excessive bucking, cutting into the circle or running off. Additionally, incidental touching of the horse with the whip, cross-cantering, balking, backing up on the longe line and excessive urging from the exhibitor should be penalized accordingly.
4. Conformation will count for up to 20 points of the total score. The horse will be judged on conformation suitable to future performance as a western pleasure or hunter under saddle competitor. The judges should look for a total picture, emphasizing balance, structural correctness and athletic capability. Performance conformation will be judged on a scale of 0-20 with 10 being average.
5. Penalties and Disqualifications
 - a. Five-point penalty: Failure to demonstrate the correct lead, jog or trot for an adequate distance to allow for proper evaluation of gait.
 - b. Disqualifications will occur in the following instances:
 - 1) Evidence of lameness – judge will immediately excuse horse from arena
 - 2) Blatant striking of horse with whip during longeing demonstration that will cause forward or lateral movement
 - 3) Fall of horse
 - 4) Horse steps over or becomes entangled in longe line.
 - 5) Improper equipment, evidence of abuse or inhumane treatment and/or other violation of ApHC rules
 - 6) Failure to show all three gaits in both directions
 - 7) Loss of control of the horse in which horse is loose in the arena
 - 8) Exhibitor disrespect toward the judge(s)

I. Yearling longe line may not be held prior to May 20. National points will not be accumulated for year-end high-point awards. Points will be accrued for horse's record only.

J. An exhibitor may show a maximum of two horses in each longe line class. The same exhibitor must show in both segments of the class. An additional handler may hold the second horse while the first horse is being worked. An additional handler may hold the first horse while the second horse is being worked. A maximum of two handlers may be used. In non-pro classes, any additional handlers must be current ApHC non-pro members. Exhibitors and handlers must not do anything to disturb any horses in the class while they change handlers.

Rules 720-723 are not assigned.

724. TRAIL

- A. This class will be judged on the performance of the horse over the obstacles, with emphasis on manners, response to the exhibitor, and attitude. Credit will be given to those horses negotiating the obstacles with style, expression, and some degree of speed, providing carefulness is not sacrificed. Credit will be given to horses showing the capability of picking their own way through course when obstacles warrant it and willingly responding to exhibitor's cues on more difficult obstacles.
- B. Horses shall be penalized for any unnecessary delay while approaching the obstacles. Horses with artificial appearance over obstacles should be penalized as should exaggerated standing in stirrups and leaning forward over horse's neck by exhibitor.
- C. A minimum of six obstacles (maximum of 10 obstacles) will be used, three of which will be mandatory and others selected from the approved list. The course shall be returned to its original design after each horse has worked. Management, when setting course, should keep in mind that the idea is not to trap a horse, or eliminate it by making an obstacle too difficult. If difficult courses are set, junior, youth, novice non-pro and non-pro trail should be less difficult.
1. Horses shall not be required to work on the rail. The course will be designed, however, to require each horse to show the three gaits (walk, jog, lope) somewhere between the obstacles as a part of its work. Gait between obstacles shall be at the discretion of the judge. Quality of movement and cadence should be considered part of the maneuver score. Enough space should be provided for a horse to jog at least 30 feet (9.15 m) and lope at least 50 feet (15.24 m) for the judge to evaluate these gaits.
 2. When distances and spaces are measured between all obstacles, the inside base to inside base measurement of each obstacle considering the normal path of the horse, should be the measuring point.
 3. The judge must walk the course and has the right and duty to alter the course in any manner. The judge may remove or change any obstacle (s)he deems unsafe or non-negotiable. All courses and obstacles are to be constructed with safety in mind so as to guard against accidents. If at any time a trail obstacle is deemed to be unsafe by the judge, it shall be repaired or removed from the course. If it cannot be repaired and horses have completed the course, the score for that obstacle shall be deducted from all previous entries in that class.
 4. The course must be posted at least one hour before scheduled time of the class.
- D. Each obstacle should receive an obstacle score and is subject to a penalty that should be subtracted. Each obstacle should be scored on the following basis, ranging from plus 1 1/2 to minus 1 1/2; -1 1/2 extremely poor, -1 very poor, -1/2 poor, 0 correct, +1/2 good, +1 very good, +1 1/2 excellent. Obstacle scores are to be determined and assessed independently of penalty points.
- E. Penalties should be assessed per occurrence as follows:
1. Disqualification (from entire class)
 - a. Use of more than one finger between reins.
 - b. Use of two hands (except for Junior horses shown with a snaffle bit or hackamore).
 - c. Changing hands on reins (except when necessary to work an obstacle).
 - d. Use of romal other than as outlined in 715.A.7.
 - e. Performing the obstacles other than in specified order.
 - f. No attempt to perform an obstacle.
 - g. Equipment failure that delays completion of pattern.
 - h. Touching the horse on the neck to lower the head or use of free hand to instill fear or praise.
 - i. Fall to the ground by horse or rider.
 - j. Riding outside designated boundary marker of the course.
 - k. Failure to enter, exit or work obstacle from correct side or direction.
 - l. Failure to perform correct line of travel within or between obstacles.
 - m. Third refusal, balk or attempt to evade an obstacle by shying or backing more than 2 strides away.
 2. 1/2-Point Penalty
 - a. Each tick of log, pole, cone or obstacle.
 3. 1-Point Penalty
 - a. Each hit of or stepping on a log, pole, cone or obstacle.
 - b. Break of gait at walk or jog for two strides or less.
 - c. Both front or hind feet in a single-strided slot or space.
 - d. Skipping over or failing to step into required space.
 - e. Split pole in lope-over.
 4. 3-Point Penalty
 - a. Break of gait at walk or jog for more than 2 strides.
 - b. Out of lead or break of gait at lope (except when correcting an incorrect lead).
 - c. Knocking down an elevated pole, cone, barrel or plant obstacle or severely disturbing an obstacle.
 5. 3 to 5-Point Penalty (Depending on severity)
 - a. Stepping outside the confines of, falling or jumping off an obstacle (back through, bridge, side pass, box, water box) with one foot.
 6. 5-Point Penalty
 - a. Dropping slicker or object required to be carried on course.
 - b. First refusal, balk or attempt to evade an obstacle by shying or backing more than 2 strides away.
 - c. Loss of control or letting go of gate.
 - d. Stepping outside the confines of, falling or jumping off an obstacle (back through, bridge, sidepass, box, water box) with more than one foot.
 7. Five (5) or more penalty points:
 - a. Blatant disobedience (kicking out, biting, rearing, striking).
 - b. Failure to ever demonstrate correct lead or gait if designated.
 - c. Failure to complete obstacle.
 - d. Second refusal, balk or attempt to evade an obstacle by shying or backing more than 2 strides away.
- F. Only one hand may be used on reins, except for junior horses shown with a snaffle bit hackamore/bosal. Hands must not be changed, except that it is permissible to change hands to work with an obstacle. While the horse is in motion, there shall be no changing of hands on the reins. Hand to be around reins. One finger between reins permitted. While horse is in motion, exhibitor's hands shall be clear of horse and saddle.
- G. Mandatory obstacles are:
1. Sidepass (over obstacle is optional). May be elevated to 12" (30.48 cm) maximum.

VARIATIONS OF SIDEPASS:

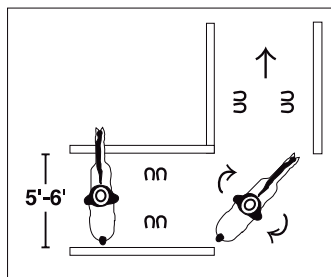

(Sidepass right, turn right, sidepass left.)

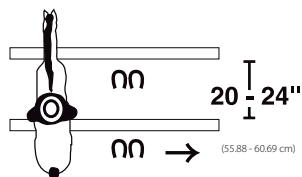

Front feet inside or back feet inside.

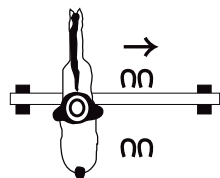

Raised object
(no more than 12 inches.)
(no more than 30.48 cm)

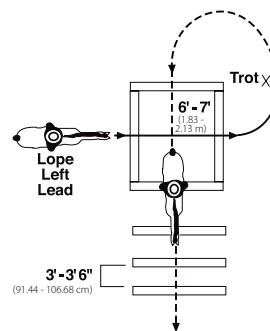
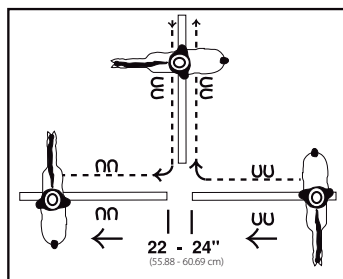

Widths may be doubled or tripled to allow for more than one stride between poles.

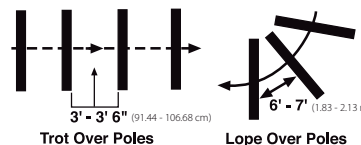

Trot overs, lope overs

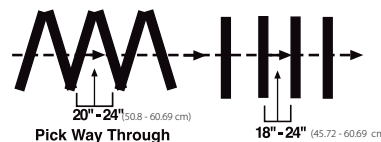

Pick Way Through

18"-24" (45.72 - 60.69 cm)

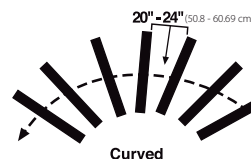

Curved

Walk overs

2. Ride over at least four logs or poles. These can be in a straight line, curved, zigzag raised or combination. The space between poles/ logs is to be measured. Elevated trot-overs and lope-overs cannot be used in novice classes. All elevated elements must be placed in a cup, notched block or otherwise secured so they cannot roll. The height should be measured from the ground to the top of the element.

- Spacing for walk-overs shall be 20-24" (50.8 - 60.69 cm) and may only be elevated to 12" (30.48 cm). Elevated walk-overs shall be set 22-24" (55.88-60.69 cm) apart.
- Spacing for trot-overs shall be 3'-3'6" (91.44-106.68 cm) (or in increments thereof) and may only be elevated to 8" (20.32cm).
- Spacing for lope-overs shall be 6'-7" (1.83-2.13m) or in increments thereof and may only be elevated to 8" (20.32cm).

3. Ride over wooden bridge. Minimum width shall be 36" (91.44 cm) wide and at least 6 feet (1.83 m) long. Bridge should be sturdy, safe and negotiated at a walk only.

4. Opening, passing through and closing gate (mandatory at ApHC-sponsored events only). A gate that will not endanger horse or exhibitor must be used. If the gate has a metal, plastic or wooden support bar under the opening, contestants must work the gate moving forward through it.

H. Optional obstacles are:

- Water hazard (ditch or small pond). No metal or slick bottom-boxes shall be used.
- Carry object from one part of arena to another. Only objects that might reasonably be carried on a trail ride may be used.
- Backing obstacle. Backing obstacles to be spaced a minimum of 28" (71.22 cm) apart. If elevated to be placed at least 30" (76.2 cm) apart. Entrants cannot be asked to back over a stationary object such as a wooden pole or metal bar.
 - Back through and around at least three markers.
 - Back through L, V, U, straight or similar-shaped course. Shall be elevated no more than 24" (60.96 cm).

BACK THROUGH AND AROUND THREE MARKERS:

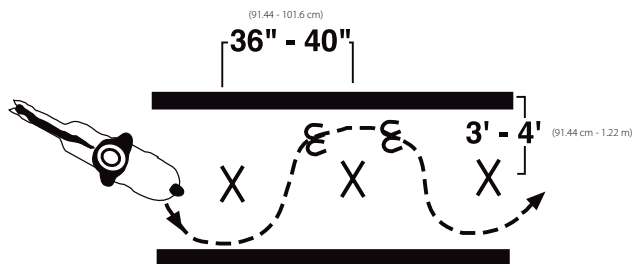
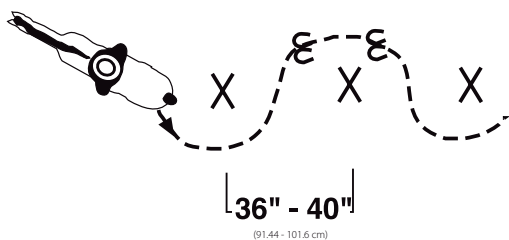
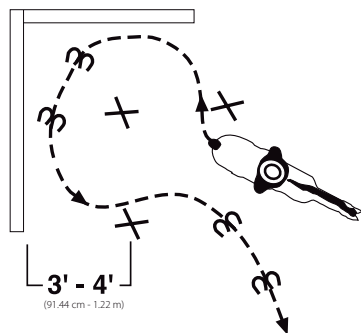
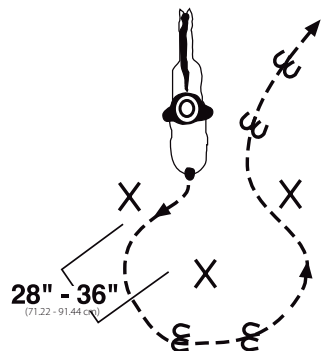

VARIATIONS OF L BACK THROUGH:

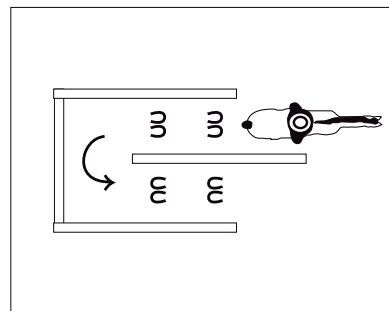
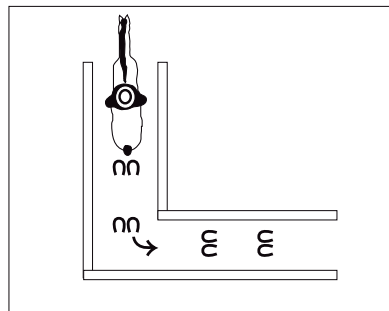

4. Put on and remove slicker.
5. Remove and replace material from mailbox.
6. Serpentine obstacles at a walk or jog. Spacing to be a minimum of 6' (1.83 m).
7. An obstacle consisting of four logs or rails, each 5'-7' (1.52-2.13 m) long, laid in a square. Each exhibitor will enter the square over log or rail as designated. When all four feet are inside the square, exhibitor will execute a turn as indicated and depart.
8. Any other safe and negotiable obstacle that could reasonably be expected to be encountered on a trail ride and meets the approval of the judge may be used.
9. A combination of two or more of any obstacle is acceptable.

I. Prohibited Obstacles

1. Tires
2. Animals
3. Hides
4. PVC pipe
5. Dismounting
6. Jumps
7. Rocking or moving bridges
8. Water box with floating or moving parts
9. Flames, dry ice, fire extinguishers, etc.
10. Logs or poles elevated in a manner that permits such to roll
11. Ground ties

J. WALK-TROT TRAIL

1. The conditions of this class are the same as outlined under trail (with the exception that contestants will not be asked to lope but may be asked to extend the jog or trot).

2. If the horse breaks into a lope for more than three consecutive strides, it shall be disqualified.
3. See YOUTH WALK-TROT DIVISION, rule 807 for rules regarding youth eligibility for youth walk-trot classes.
4. See NON-PRO WALK-TROT DIVISION, rule 901.E for rules regarding non-pro eligibility for non-pro walk-trot classes.

725. GAMING CLASSES GENERAL RULES

DISCLAIMER: The ApHC encourages the use of ASTM/SEI approved protective headgear by all exhibitors and requires youth exhibitors 18 years of age and younger to wear ASTM/SEI approved protective headgear in all game classes. Game classes constitute an inherently dangerous activity and exhibitors participate at their own risk. All exhibitors in all game classes at ApHC approved and/or sponsored show or events, and the parents or guardians of all such exhibitors who are minor children, will be required to execute a release in form satisfactory to the ApHC indemnifying and holding harmless the ApHC and the show sponsors from any liability for injury or death arising from such exhibitor's participation in any game class, or such exhibitor will not be allowed to participate in any game class at any such approved and/or sponsored show or event.

A. In all game classes, it is mandatory to wear appropriate western attire, which includes a long-sleeved shirt and cowboy boots. Chaps are optional in games. The exhibitor must wear either a western hat or ASTM/SEI approved protective headgear. If the exhibitor wears a hat, the hat must be on the exhibitor's head when the exhibitor enters the arena. Youth exhibitors 18 years of age and younger are required to wear ASTM/SEI approved helmet with safety harness attached and fastened in all game classes. ASTM/SEI approved protective headgear, while optional for adults, is strongly recommended for use by all exhibitors in all game classes.

1. In timed game events, a five-second penalty will be assessed if the hat or helmet is not on the exhibitor's person for the entire time the exhibitor is in the arena.
- B. In Stump and Stake Races if arena size permits, horses should be run horse against horse. If arena size does not permit horses to be run safely horse against horse, horses may be run on time.
- C. In any timed or racing (speed) events all arena gates must be closed before contestants compete. Exhibitors will not be allowed to enter or leave the arena moving at full speed. Exhibitors will not be allowed to enter the arena until the course or courses have been pronounced ready by the judge(s).
1. Once the arena has been pronounced ready by the judge(s) and the entry gate is open, exhibitor(s) have 30 seconds to enter the arena. Entries not in the arena at the expiration of this time limit shall be disqualified.
- D. In horse-against-horse gaming classes, once the arena has been pronounced ready by the judge(s) and the entry gate is open, both horses have 30 seconds to enter the arena. The determination of which horse will enter first is decided outside the arena in advance of the heat by the flip of a coin or by mutual consent of the entrants competing in that heat. Entries not in the arena at the expiration of this time limit shall be disqualified.
- E. Games classes will be started by an audible signal (bell, horn, whistle, gong, or buzzer). The signal will not be given until the gate is closed. In all time trials and all classes run on time, exhibitors will have 30 seconds from time of audible signal to get over start line.
- F. When an exhibitor competes in a timed event or time trials, each qualifying time shall be announced over the public address system by the show announcer immediately following his or her qualifying run. Any exhibitor receiving no time due to disqualification shall also be announced over the loud speaker by the show announcer.

- G. Any horse breaking or crossing the plane of the starting line with any part of its body after the judge signals time and before the starting signal will be disqualified for that heat.
- H. Horses not under reasonable control will be disqualified.
- I. When possible it is recommended the electric timers be used as official time in all timed events. When hand timers are used a minimum of three watches is recommended, with the median time being the official time. (The median time is the time indicated by two of the three stop watches, if two agree. If no two watches agree, the median time is the time indicated by the watch which has neither the fastest nor slowest time).
- J. Care should be taken to see that the ground surrounding barrels and poles is safe and free from holes. Exhibitors may request that area around stakes and stumps be raked and leveled.
- K. If only one exhibitor qualifies in a class, the class shall be considered completed. Should no exhibitors qualify the class may be rerun once in order to establish a winner.
- L. In case of mechanical failure of either an electrical timer or stop watches, an exhibitor may be given a rerun in any event in which the exhibitors qualify by time.
- M. In timed events, the starting and finishing time shall be taken the instant the horse's chest reaches the plane of the timing line.
- N. In Open classes, an exhibitor may ride only one horse except where the class is a totally timed event. Non-Pros can only ride one horse in Non-Pro Camas Prairie Stump Race and Non-Pro Nez Perce Stake Race **except that a non-pro exhibitor may ride a maximum of two horses in these two classes provided they are timed-only classes.** Youth exhibitors may only ride one horse in youth Nez Perce stake race and youth camas prairie stump race **except that a youth exhibitor may ride a maximum of two horses in these two classes provided they are timed-only classes.**
- O. Each class in a multi-judge show shall be run concurrently. However, in timed gaming events at multi-judge shows, a maximum of one run per every two judges may be allowed at show management's sole discretion.
- P. Paintings and markings on the horse shall be permitted in games classes.
- Q. An exhibitor may not walk through the course in order to qualify for a placing position nor in the run-off for a tie, except in walk-trot games classes.
- R. In all game classes, it is acceptable to ride two-handed.

726. TIME TRIAL ELIMINATIONS OR TIMED EVENTS

- A. DISQUALIFICATION:** Any horse running in the time trial eliminations or when the class is run on time only, shall be disqualified from the entire class for any of the following infractions:
1. Horse not running to the right hand barrel in the Camas Prairie Stump Race.
 2. Horse not running down the right hand side of the stakes at the start in the Nez Perce Stake Race.
 3. Fall of horse or rider.
 4. Striking horse forward of cinch.
 5. Touching barrel or stake with hand.
 6. Running off course.
 7. Crossing finish line before completion of pattern.
 8. Equipment failure or casting of shoe unless entry can continue without interruption.
 9. Injury to horse or exhibitor.
- B. FIVE SECOND PENALTY:** When competing for time or in time trials in Camas Prairie Stump Race and Nez Perce Stake Race, a five-second penalty shall be added to the final time for each knocked over barrel or stake and if exhibitor loses hat (see Rule 725.A.1).

727. HORSE AGAINST HORSE

- A. When racing horse against horse and one exhibitor disqualifies through an infraction, the remaining exhibitor must maintain his or her reasonable speed and complete the course. Reasonable speed shall be considered as any gait faster than a walk. Walking through the remaining course or loss of forward motion will result in disqualification of that heat.
- B. When racing horse against horse, if any exhibitor incurs any type of infraction resulting in disqualification in the same heat in which the opposing exhibitor is disqualified for a similar infraction, both exhibitors shall be allowed to rerun.
1. Example: If an exhibitor touches a stump or stake with his hand s/he shall be eliminated unless the other entry in the same heat incurs a similar infraction.

C. DISQUALIFICATION FROM HEATS ONLY

1. Falling

- a. A fall in a heat (horse against horse) shall NOT disqualify an exhibitor from the entire class. It shall be considered as a disqualification from that heat only. When a fall and a knock-down of a barrel or stake or similar infraction occurs in the same heat, they shall nullify one another and the heat shall be rerun until one exhibitor finishes the course clean.
2. Knocking over barrel or stake.
3. Touching barrel or stake with hand.
4. Running off course.
5. Crossing start line before signal to start.
6. Crossing the finish line before completion of pattern.
7. Not maintaining speed.
8. Equipment failure or casting of a shoe that causes the horse to be pulled up, shall disqualify the horse for that heat only. Upon repair of equipment they may return to the next elimination heat (if any) when called by the show announcer.
9. Horse not running to the right-hand barrel in the Camas Prairie Stump Race.
10. Horse not running down the right side of the stakes at the start of the Nez Perce Stake Race.
11. Loss of hat or helmet from the exhibitor's person.

D. DISQUALIFICATION FROM ENTIRE CLASS

1. Striking horse forward of cinch.
2. Injury to horse or exhibitor.
- E. When exhibitors are running horse against horse and an entry is disqualified from the entire class (per rule 711.C, 711.E or 727.D.2) or scratched for any reason, the remaining entry will automatically advance in the bracket, even if s/he has sustained a disqualifying infraction for any reason (such as knocking over stake or stump.)
1. The entry that was disqualified from the entire class (per rule 711.C, 711.E or 727.D.2) or scratched for any reason, shall be carried on the bracket as a bye for the remainder of the class.
- a. Should a disqualification (per rule 711.C, 711.E or 727.D.2) occur during the final placing of the class, all placings will automatically be moved up to fill the vacancy of the disqualified entry.
- b. Should a scratch occur during the final placing of the class, the scratched entry shall receive the placing they would have received had they run the heat and lost.

NOTE (for quick reference)

- 711.C. In all classes and all divisions of classes, if a horse's mouth is found to be bloody, disqualification is at the judge's discretion. Judges may also, at their discretion, disqualify a horse anytime it is exhibited with an open, raw or bleeding sore that repeatedly comes in contact with the hackamore.
- 711.E. Any exhibitor striking or hitting the horse forward of the cinch with any object (other than the hands) shall constitute immediate disqualification from any performance class (exception: Hunter and Jumpers). Any exhibitor striking the horse on the head with anything, including the hands, will be subject to disqualification. This rule will be strictly enforced by the judge. These objects include romal, spurs, whip, bat, quirt, crop, switches, wire, reins, or any other object.
- 727.D.2. It is a disqualification from the entire class if there is an injury to horse or exhibitor.

F. FIVE-SECOND RULE

1. When both horses enter the arena, they will have 30 seconds to get behind the starting line and in reasonable position. If they do not, one or both will be disqualified for that heat.
2. A solid line will indicate the starting line.
3. Once horses are behind the starting line, they must stay there. No riding out.
4. Once in reasonable position, the judge will signal time with an audible signal and the timer will start.
5. When "5" (five) seconds are up, the starting signal will sound.
- G. If exhibitors choose to flip a coin to determine the direction or which course they shall compete on, the paddock judge or show judge shall flip the coin.

728. BRACKETS FOR STUMP AND STAKE RACES

- A. At ApHC-approved shows, the Nez Perce Stake Race and Camas Prairie Stump Race may be run horse against horse.
1. Show management may either randomly draw the bracket for the horse-against-horse races or run time trial eliminations first and then seed the bracket with the fastest horse running against the slowest horse per the diagram in Rule 728.B.
2. If there are more than 8 horses, it is acceptable to use a 16-horse bracket with byes.
3. If there are more than 16 horses, the class can be eliminated by time down to an 8-horse or 16-horse bracket. Or, larger brackets can be used as long as they are in powers of 4 such as a 32-horse bracket.
4. If more than eight placings are awarded, a 16-horse bracket should be used.
5. If there are fewer than eight horses entered, the bye system should be invoked, and those byes shall be placed only in the first bracket. If there are fewer than eight qualifiers for the final race through disqualifications, the bye system shall be used.
6. No horse disqualifying shall be allowed to rerun for a qualifying position.

B. At ApHC-sponsored shows, time trials are to be used to determine the finalist positions on the 16-horse brackets and horses will be seeded with the fastest horse running against the slowest horse according to the following bracket.

- A. Fastest time
- B. 2nd fastest time
- C. 3rd fastest time
- D. 4th fastest time
- E. 5th fastest time
- F. 6th fastest time
- G. 7th fastest time
- H. Slowest qualifying time

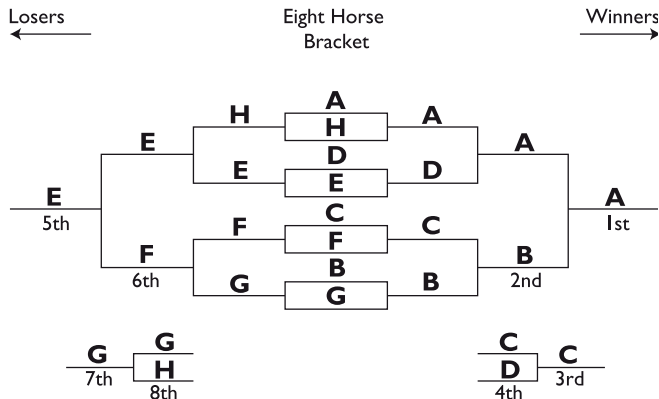

C. In an elimination where there are numbers which do not happen to fall upon powers of four, it is necessary to invoke the "Bye" system. By doing this, the numbers of byes necessary are drawn. For example, this illustration will use six entries and proceed to eliminate them by using the bye system. Use a chart which is in powers of four: This is necessary to arrive at a winner. In this illustration the horses are named A, B, C, D, E and F. Since two more horses are needed to complete eight which is the next power of four higher than six, draw out two byes placed at the top and bottom of bracket. To determine the finalist positions on the bracket, horses will be seeded with the fastest horse running against the slowest horse, and must be seeded according to the diagram below. Assuming that A and C win the next race and that when they run A will win, this gives a first and second place horse. Then go back and run B and D to determine which is third and fourth place. To determine fifth and sixth place, E and F will run. The winner becomes fifth place, the loser becomes sixth place.

- A. Fastest time
- B. 2nd fastest time
- C. 3rd fastest time
- D. 4th fastest time
- E. 5th fastest time
- F. Slowest time

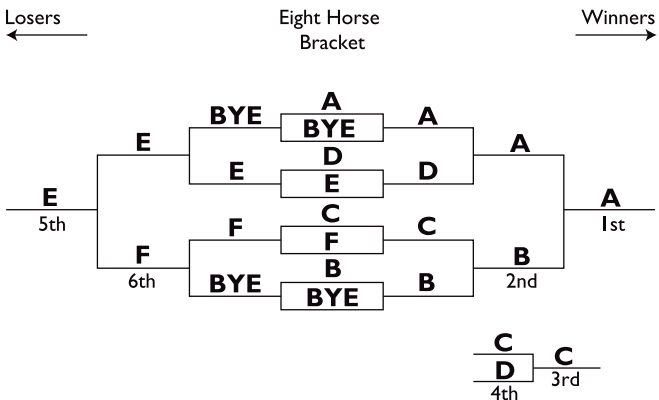

D. Use brackets in powers of four. Get byes out of the way during the first race. Select brackets closest to the number of entries and put in byes to fill brackets.

1. When randomly drawing the bracket, place byes alternately from the top and from the bottom to fill the necessary spaces.
2. When seeding the bracket with the fastest horse running against the slowest horse, byes should be awarded to horses based upon their elimination times with the first bye going to the fastest horse, the second bye to the second fastest horse and so on until the bracket is filled.

729. CAMAS PRAIRIE STUMP RACE

- A. The race shall be run in traditional Nez Perce fashion if arena size permits. Two horses at a time on two opposite three-barrel courses, triangular in nature, will race from a common starting and finish line to the barrel on their right, turning right and racing to the barrel on the left of the starting line around it to the left and race to the barrel farthest from the starting line turn left around this third barrel and race to the starting line which is now the finish line, until eliminations are complete.
- B. Original positions will be drawn; the bye system may be invoked in the event of an odd number of entries.
- C. The two opposite three-barrel courses, triangular in nature, should be set up with a common start/finish line. The front barrels 30 feet (9.15 m) from the starting line; barrels to be 75 feet (22.86 m) apart with the back barrel 94 feet (28.65 m) from the finish line. A course may be reduced by 3 to 5 feet (91 cm–1.52 m) to fit a smaller arena.

D. COURSE LAYOUT:

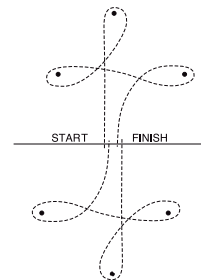

730. NEZ PERCE STAKE RACE

- A. The race shall be run in traditional Nez Perce fashion if arena size permits. Two horses at a time on two adjacent six-stake courses will race from a common start/finish line, down the right side of the course to the farthest stake, then turn left, weave through stakes, and race to starting point. Losing horse is eliminated. Repeat this elimination procedure until elimination is complete.
- B. Original positions will be drawn; the bye system will be invoked in the event of an odd number of entries.
- C. Two adjacent six-stake courses should be set up with a common finishing line. First stake 21 feet (6.4 m) from starting line; other stakes 21 feet (6.4 m) apart.

D. COURSE LAYOUT:

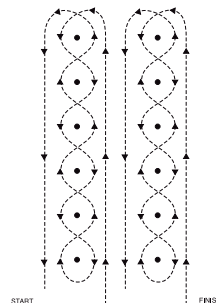

731. FIGURE 8 STAKE RACE

- A. This is a timed event.
- B. The start/finish line is 30 feet (9.15 m) wide and marked by two upright markers (cones or pylons) short enough to not interfere with the timer if one is used. Short pylons or cones are recommended.
- C. There are two stakes in this event. The stakes shall be 80 feet (24.38 m) apart. The first stake shall be 21 feet (6.4 m) from the start/finish line and the second stake shall be 101 feet (30.78 m) from the start/finish line if arena size permits. The pattern may be shortened depending upon arena size; however the two stakes must always be placed 80 feet (24.38 m) apart, regardless of the distance between the first stake and the start/finish line.
- D. Exhibitor shall cross the start/finish line and run down the right side or left side of the poles to the second pole making either a right- or left-hand turn. Exhibitor shall not cross between the two poles before making the first turn. Exhibitor shall then run to the first pole and make a turn in the opposite direction. Exhibitors must then run back to the second pole and repeat first turn then run straight back down either the left or right side of the poles (opposite side than when first crossing start line and running to second pole) and cross the start/finish line. Pattern must be run according to diagram in G.
- E. A no-time is given if either of the upright poles or either of the two upright markers are knocked down.
- F. An exhibitor may not walk through the course in order to qualify for a placing position nor in the run-off for a tie.

G. COURSE LAYOUT:

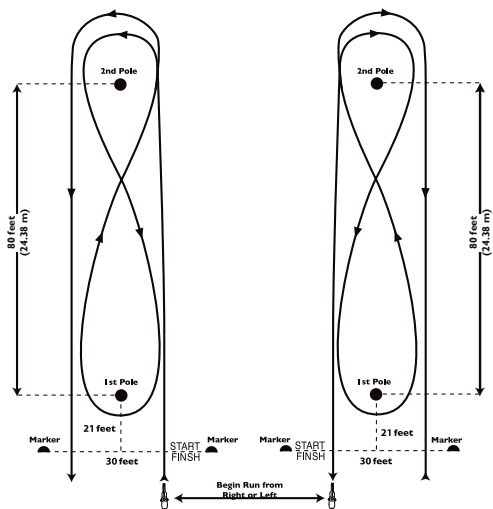

732. KEYHOLE RACE

- A. The starting line shall be 50 to 100 feet (15.24–30.48 m) (according to arena size) from the entrance to the keyhole. The entrance shall be 4 feet (1.21 m) wide and 10 feet (3.05 m) long, connected to a circle 20 feet (6.09 m) in diameter. Time starts as the contestant crosses the starting line. He/she shall proceed through the entrance, turn right or left in the circle, return through the entrance and cross the finish line. An exhibitor is disqualified if a horse steps on or outside of the chalk line. A judge or judges must be at the keyhole to decide upon these qualifications, and their decisions will be final.

- B. A marker should be placed at each end of the starting and finish line and the horse must start and finish by passing between the markers. A running start is permissible. Fastest time wins. An exhibitor may not walk through the course in order to qualify for a placing position or in the run-off for a tie.

C. KEYHOLE RACE COURSE LAYOUT

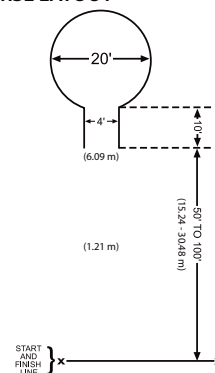

733. WALK-TROT GAME CLASSES

- A. Except as noted below, general gaming class rules and TIME TRIAL ELIMINATIONS OR TIMED EVENTS rules apply to all walk-trot game classes.
- B. Approved walk-trot game classes: Camas Prairie Stump Race, Nez Perce Stake Race, Keyhole Race, Figure 8 Stake Race (youth only).
- C. If the horse breaks into a lope for more than three consecutive strides, it shall be disqualified.
- D. These are timed events where the fastest time wins.
- E. See YOUTH WALK-TROT DIVISION, rule 807 for rules regarding youth eligibility for youth walk-trot classes.
- F. See NON-PRO WALK-TROT DIVISION, rule 901.E for rules regarding non-pro eligibility for non-pro walk-trot classes.

734. ROPE RACE

- A. Small four foot ropes are loosely tied to a wire line or lariat stretched taut across the arena 2 feet (60.96 cm) above the head of a mounted horseman (one rope less than the number of exhibitors). At the direction of the starter, the exhibitors race to take hold of one of the dangling ropes with one hand. The exhibitor without a rope will be eliminated. Another small rope shall be removed, again leaving one less rope than exhibitors. Exhibitors will repeat race to the lariat or wire until all but one is eliminated. The last exhibitor eliminated will win second place and the exhibitor holding the last rope shall be the winner. The exhibitor eliminated in the heat prior to the final race will be awarded third place; fourth place shall be awarded to the exhibitor eliminated in the previous heat. The number of class placings shall be specified in the premium list. EXHIBITOR MAY RIDE ONLY ONE HORSE.
- B. In the event of a tie between two exhibitors on the same rope, those two will immediately run to determine the winner, separate and apart from the balance of exhibitors with winner of tie returning to race with the others and loser being eliminated as outlined above. An exhibitor must hold onto rope and be mounted until judge signals heat finished and next heat to begin. Any unnecessary roughness, unsportsmanlike conduct, etc., on the part of an exhibitor may be grounds for disqualification at the discretion of judge. Exhibitors' working order may be drawn for permanent working positions throughout Rope Race contest.
- C. A fall of horse or exhibitor shall be a disqualification from the heat in either the eliminations and/or finals. Any exhibitor striking the ropes with a bat or any other object other than his or her hands is automatically disqualified from the class in either the eliminations and/or finals.

- D. Any horse touching the starting line after the judge signals time and before the starting signal, will be disqualified for that heat. One or more horses may be disqualified; however, that heat shall be run.
- E. Starting line should be 75 to 80 feet (22.86–24.38 m) from the finish line.
- F. At the discretion of the show management eliminations may be held in the Rope Race to eliminate all but eight horses. Classes may be divided into two or more heats eliminating down to equal numbers in each heat to arrive at the eight horses to compete in the finals.
- G. Additional judges may be appointed by the show management to watch for ties and/or fouls. These judges should stand at a distance from the ropes so as not to interfere with the actual running of the Rope Race.
- H. In the Rope Race, equipment failure or casting of a shoe shall disqualify the horse from the class unless the entrant can continue without interruption.
- I. When horses have been eliminated to the number of awards being given and two or more horses are eliminated by the Five-Second-Rule, the placing shall be at the discretion of the judge in the order of violations.

J. FIVE-SECOND RULE

- 1. When horses enter the arena, they will have 30 seconds to get behind the starting line and in reasonable position. If they do not, one or more will be disqualified for that heat.
- 2. A solid line will indicate the starting line.
- 3. Once horses are behind the starting line, they must stay there. No riding out.
- 4. Once in reasonable position, the judge will signal time with an audible signal and the timer will start.
- 5. When “5” (five) seconds are up, the starting signal will sound.

Rules 735-739 are not assigned.

740. CATTLE CLASSES

A. MANDATORY EQUIPMENT AND ATTIRE

- 1. See WESTERN PERFORMANCE EQUIPMENT and ATTIRE.
- 2. The hat must be on the exhibitor's head when the exhibitor enters the arena.
- 3. Chaps are optional at ApHC-approved shows but are mandatory at ApHC-sponsored shows, except as stated in (a) below:
 - a. In roping and team penning classes, chaps are optional as a western requirement at all ApHC shows.
- 4. In timed cattle classes at multi-judged shows, a maximum of one run per every 2 judges is allowed at show management's sole discretion.

741. WORKING COW HORSE

- A. Both the cow work portion of this event and the reined work portion are mandatory. Scoring emphasis on the cow work portion shall be based on the horse maintaining control of the cow at all times, exhibiting superior cow sense and natural cow working ability without excessive reining or spurring. Failure of an exhibitor to attempt to complete the cow work portion of the class, as well as the reined work, will result in the exhibitor not being considered an entry in the class. A horse going off pattern in the reined work will receive a score of zero. A horse that attempts both the reined work and the cow work portions may be placed, even if disqualified in one portion of the class. (Example: If a horse is disqualified and receives a 0 score for the reined work, but scores a 70 for the cow work, its total score would be 70 and the horse would be eligible for placing.)
- B. In approved working cow horse classes, any of the twelve ApHC-approved patterns may be used. A pattern is to be selected by the judge of the class and used by all contestants in the class. Each contestant will cause his horse to travel at the gait indicated for each part of the pattern. When judging reined work, the judge should refer to the reining portion of the handbook for scoring/penalty guidelines, except that the reined work in working cow horse will be scored 60-80.

C. Prescribed Cow Work:

- 1. Judging begins when the contestant enters the arena. There shall be no schooling between the completion of the rein work and cow work when the cow work immediately follows the rein work; the penalty for this will be a zero.
 - 2. At the start of the work, each contestant upon receiving a cow in the arena, shall hold the cow on the prescribed end of the arena for sufficient time to demonstrate the ability of the horse to contain the cow on that end. Boxing: Working the cow on the end of the arena until such time as the contestant has proven the ability of the horse to hold the cow. The horse should exhibit superior cow sense and natural cow-working ability without excessive reining or spurring. In the head-to-head working position, the degree of difficulty shall be considered.
 - 3. After a reasonable amount of time, the contestant shall take the cow down the fence, making at least one turn each way on the fence. Turning on the fence: A good turn on the fence may be defined as one in which the cow, while being run down the fence on one side of the arena, is turned in the other direction and held near the same fence while being run in the new direction. During the turn the horse should use himself in a controlled, athletic manner, using its hocks to stop and drive out of the turn, while using its front end to balance and turn. The contestant must get at least one turn in each direction. To be considered a turn, the contestant must be close enough to the cow to be the cause of the turn. The turn must be tight enough so as not to be considered just circling the fence. More than two good turns in each direction should not result in extra credit but also should not be penalized, unless the cow is thereby too exhausted to circle correctly. One turn each way may not necessarily result in extra credit if the horse and/or cow are out of control.
 - 4. The contestant shall then take the cow to an open part of the arena and circle it at least once in each direction. Circling: Maneuvering the cow smoothly at least 360 degrees in each direction without interference from the fence. The circle's size, symmetry, speed and relative balance from right and left show control. Tightening the circles down with fast head-to-head speed will be a credit situation. The circles should be completed before the cow is exhausted.
 - 5. The exhibitor has thirty (30) seconds in which to accept or reject the cow. If s/he does not reject the cow within 30 seconds, the cow is hers/his. If s/he does exercise her/his option to reject the cow, s/he gets one new cow.
 - 6. The judge has the option of calling for a new cow at any time if he/she has determined that the cow drawn is unreasonably difficult or unworkable even if the exhibitor has already accepted or rejected the cow.
 - a. It is up to the exhibitor to determine if they wish to continue working the cow they currently have drawn or to accept the new cow that the judge has called for.
- D. The judge should take into consideration the size of the arena, condition of the ground and disposition of the cattle in scoring each work. If ground, arena and/or weather conditions are deemed unfavorable by the exhibitors, they may inform the judge who may elect to alter the required cattle work for safety reasons.
- 1. The greater the difficulty of the run, the more credit should be given. The difficulty may be due to the extreme speed or stubbornness of the cow, or the cow's reluctance to move down the fence when sufficiently driven by the contestant. The most controlled cow work with the highest degree of difficulty should be marked the highest. Bad manners exhibited by the horse will be penalized under run content.
 - 2. Allowing the horse to quit working after 30 seconds has elapsed and before the judge signals for a new cow, will result in a zero score. The judge may blow his/her whistle at any time to terminate the work. A score of zero will be given if the work is not complete at that point. If a new cow is called,

judging and time will start over with the new cow. With a multiple judge system, any one of the judges may signal for a new cow. Judging ends when the whistle blows.

3. In the cow work phase of any class, one hand on the horn may be used to prevent the fall of the rider. Holding the horn excessively may be penalized under run content.
 4. During the cow work, when a cow leaves the working area, it is automatic that the contestant will receive a new cow and scoring will begin again with the new cow.
- E. At the discretion of the judge, cow work may be done immediately following each individual's pattern work or immediately after completion of pattern work by all horses being exhibited.
- F. Scoring will be on a basis of 60 to 80 with 70 denoting an average performance. The same basis of scoring shall apply to both the reined work and cow work. In the event of a tie, the entry with the highest cow work score will be declared the winner. If still tied, a work-off on the cattle work will be required.
1. 5-point penalties
 - a. Not getting one turn each way (5 points each way).
 2. 3-point penalties
 - a. Biting or striking the cow
 - b. Hanging up on the fence (refusing to turn)
 - c. Exhausting or overworking the cow before circling
 - d. Knocking down the cow without having a working advantage
 3. 2-point penalties
 - a. Going around the corner of the arena before turning the cow when going down the fence (when the cow's head breaks the plane of the 2-point penalty marker).
 4. 1-point penalties
 - a. Loss of working advantage
 - b. For each length horse runs past cow. A length is one horse length of daylight between the cow's head and the top of the horse's tail.
 - c. Using the corner or the end of the arena to turn the cow when going down the fence. In an oval arena, when the cow's head breaks the plane of the end marker.
 - d. Changing sides of arena to turn cow (1 point each time)
 - e. Slipping a rein
 - f. Turning cow before passing middle marker on first turn
 5. Zero (0) score
 - a. Turning tail to the cow
 - b. Fingers between the reins
 - c. Deliberate spurring or use of the romal forward of the cinch
 - d. Leaving the work area before the pattern or work is complete
 1. Any horse that is out of control while working the cow, thus endangering the rider (i.e. crossing the path of the cow) shall be called off the cow.
 2. Any horse that runs over the cow thus causing the fall of horse and/or rider shall terminate the work at that time.
 - e. During the cow work, use of two hands on the reins, except with junior horses ridden two handed in an acceptable snaffle bit or bosal
 - f. Fall of horse or rider
 - g. Balking
 - h. Schooling the horse between the rein and cow work when the cow work immediately follows rein work

Note: A judge may blow his/her whistle at any time to terminate the work. A score of zero will be given if the work is not complete at that time.

G. The following characteristics of the horse are considered faults:

1. Exaggerated opening of the mouth
2. Hard or heavy mouth
3. Nervous throwing of head
4. Lugging on bridle
5. Halting or hesitation while being shown, particularly when being run out, indicating anticipation of being set up
6. Losing a cow or being unable to finish a pattern because of a bad cow – the contestant should be penalized at the judge's discretion.
7. Touching the horse or saddle with the free hand except during the cow-work portion of the class where the rider may hold onto the horn.

H.

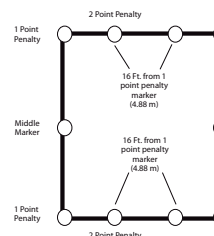
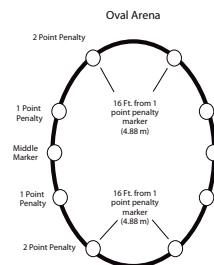

I. The characteristics of a good working cow horse are:

1. Good manners
2. Shifty, smooth and having its feet under it at all times; when stopping, hind feet should be well under it
3. A soft mouth and should respond to a light rein, especially when turning
4. Head should be maintained in its natural position
5. Work at reasonable speed and still be under control of the rider

J. HACKAMORE/SNAFFLE BIT WORKING COW HORSE

1. Open to horses five and under shown in acceptable hackamore or snaffle bit working in the same manner as prescribed for bridled horses, except must be shown two-handed. No cross entry will be allowed between Hackamore/Snaffle Bit Working Cow Horse and Junior Working Cow Horse at the same show.
2. Once a horse has been shown in anything other than an acceptable snaffle bit or hackamore/bosal, it is ineligible to compete in hackamore/ snaffle bit classes.
3. This is an optional, non-pointed class.

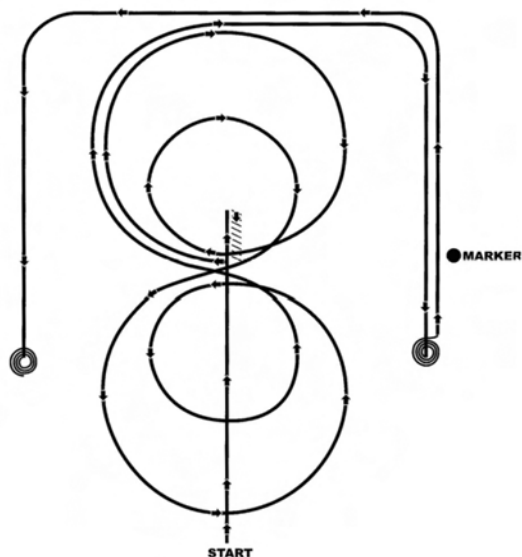

WORKING COW HORSE PATTERN #1

1. Start at end of arena. Run down middle past center marker to sliding stop.
2. Back up 10 to 15 feet (3.05–4.57 m) to center. 1/4 turn left.
3. Pick up right lead, big fast circle, small slow circle.
4. Change leads to left, big fast circle, small slow circle.
5. Change leads to right, do not close this circle.
6. Run around end of arena and down the side (approximately 20 feet (6.09 m) from fence, past center marker and come to a sliding stop.
7. Complete 3 1/2 spins to the right.
8. Continue back down side and end of arena to other side (approximately 20 feet (6.09 m) from fence, go past center marker and come to a sliding stop.
9. Complete 3 1/2 spins to the left.
10. Hesitate to complete pattern.

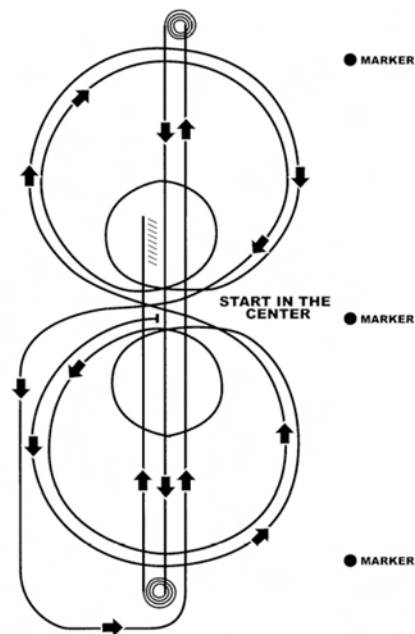

WORKING COW HORSE PATTERN #2

Trot to center of arena, stop. Start pattern facing toward judge.

1. Proceed to center of arena, stop. Pick up left lead, complete 3 circles to the left (the first one large and fast, the second small and slow, the third large and fast).
2. Change leads at center of arena.
3. Complete 3 circles to the right (the first one large and fast, the second small and slow, the third large and fast).
4. Change leads at center of arena.
5. Do not stop, continue on to run downs.
6. Run to far end past the marker to a sliding stop. Hesitate.
7. Complete 3 1/2 spins to the left. Hesitate.
8. Run to far end past the marker to a sliding stop. Hesitate.
9. Complete 3 1/2 spins to the right. Hesitate.
10. Run past center marker to a sliding stop. Hesitate.
11. Back 10 to 15 feet (3.05–4.57 m) in a straight line. Hesitate.
12. Hesitate to complete pattern.

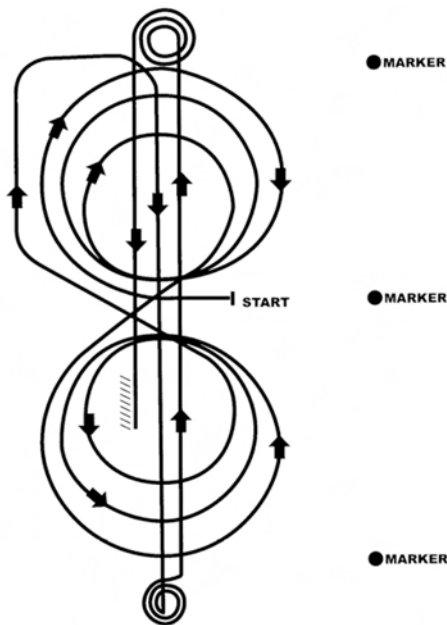

WORKING COW HORSE PATTERN #3

Trot to center of arena, stop. Start pattern facing toward judge.

1. Begin on right lead complete 3 circles to right (2 big fast circles followed by 1 small slow circle), change to left lead.
2. Complete 3 circles to left (first 2 big, fast circles followed by 1 small, slow circle). Change to right lead.
3. Continue loping around end of arena without breaking gait.
4. Run up center of arena to far end past the end marker and come to a sliding stop.
5. Complete 2 1/2 spins to the right.
6. Run up center of arena past the end marker, come to a sliding stop.
7. Complete 2 1/2 spins to the left.
8. Run back to middle of the arena past the center marker and come to a sliding stop.
9. Back 10 to 15 feet (3–4.57 m) in a straight line.
10. Hesitate to complete pattern.

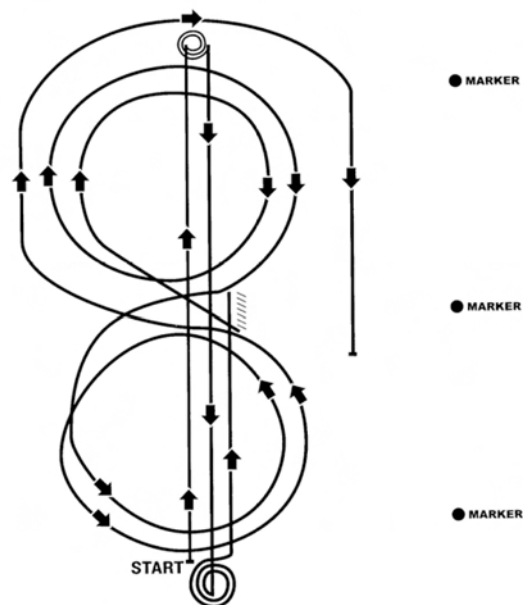

WORKING COW HORSE PATTERN #4

1. Start at end of arena.

2. Run up center of arena past the end marker and come to a sliding stop. Complete 2 1/2 spins to the left.
3. Run to other end of arena past the end marker and stop. Complete 2 1/2 spins to the right.
4. Run past the center marker and stop.
5. Back 10 to 15 feet (3.05–4.57 m) in a straight line.
6. Complete 1/4 turn to the left, hesitate. Begin on right lead. Circle to the right.
7. Complete one small, slow circle and one large, fast circle. Change leads to the left.
8. Complete one small, slow circle and one large, fast circle. Change leads to the right.
9. Run around end of arena to the other side, past center marker, at least 20 feet (6.09 m) from fence and come to sliding stop.
10. Hesitate to complete pattern.

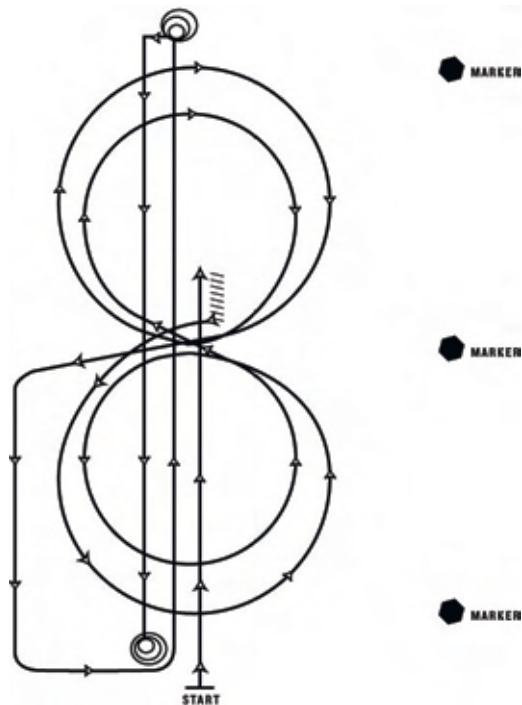

WORKING COW HORSE PATTERN #5

This pattern works best when the exhibitor and cattle enter from the same end of arena.

1. Start at end of arena.
2. Run past the center marker and stop.
3. Back up at least 10 feet.
4. Complete 1/4 turn to the left.
5. Complete 2 circles to the left, the first one large and fast and the second small and slow. Change leads at the center of the arena.
6. Complete two circles to the right, the first one small and slow, the second large and fast. Change leads at the center of the arena.
7. Continue around end of arena without breaking gait or changing leads, run down center of arena past end marker, come to a square sliding stop.
8. Complete 3 1/2 spins to the right.
9. Run down center of arena past end marker and come to a square sliding stop.
10. Complete 3 1/2 spins to the left.
11. Hesitate to complete pattern.

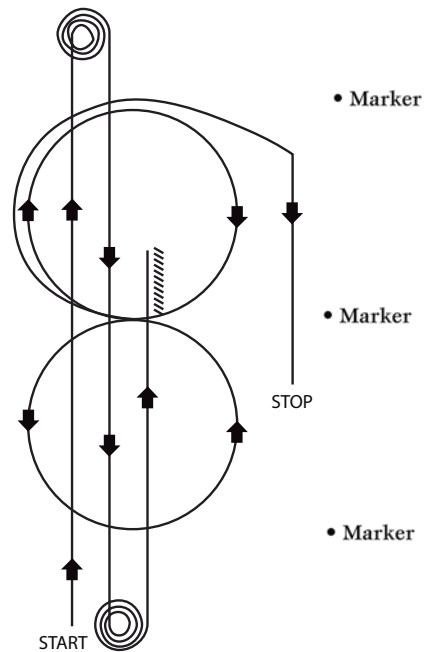

WORKING COW HORSE PATTERN #6

1. Start at end of arena.
2. Run down the middle of the arena, past the end marker and come to a sliding stop.
3. Complete 3 1/2 spins to the right.
4. Run to the other end of the arena, past the end marker and come to a sliding stop.
5. Complete 3 1/2 spins to the left.
6. Run back to the middle of the arena, past the center marker and stop.
7. Back at least 10 feet. Hesitate.
8. Complete 1/4 turn to the left.
9. Beginning on right lead, complete one circle to right, change leads. Complete one circle to left. Change leads and begin a large fast circle to the right, but do not close this circle.
10. Run straight down the right side of the arena past the center marker and do a sliding stop at least 20 feet (6 meters) from the wall or fence.
11. Hesitate to complete pattern.

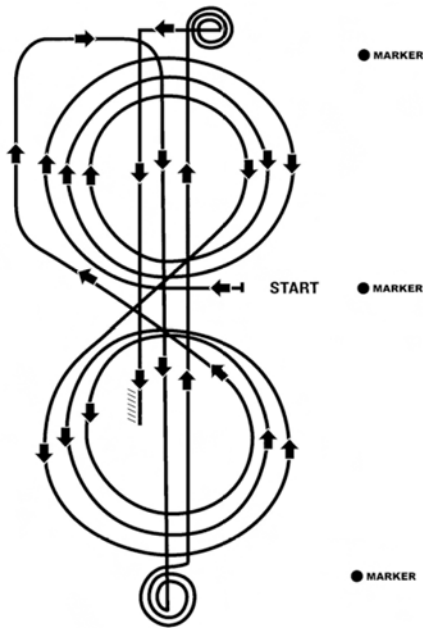

WORKING COW HORSE PATTERN #7

Trot to center of arena, stop. Start pattern facing toward judge.

1. Begin at center of arena. Pick up right lead and complete 3 circles (the first big, fast; the second small, slow; the third big, fast). Change leads to the left.
2. Complete 3 circles (the first big, fast; the second small, slow; the third big, fast). Change leads to the right.
3. Continue loping around end of arena without breaking gait or changing leads.
4. Run down the center of arena, past end marker, and come to a sliding stop. Hesitate.
5. Complete 2 1/2 spins to the right.
6. Run down the center of arena, past end marker, and come to a sliding stop. Hesitate.
7. Complete 2 1/2 spins to the left.
8. Run past center marker and come to a sliding stop.
9. Back up at least 10 feet (3.05 m).
10. Hesitate to complete pattern.

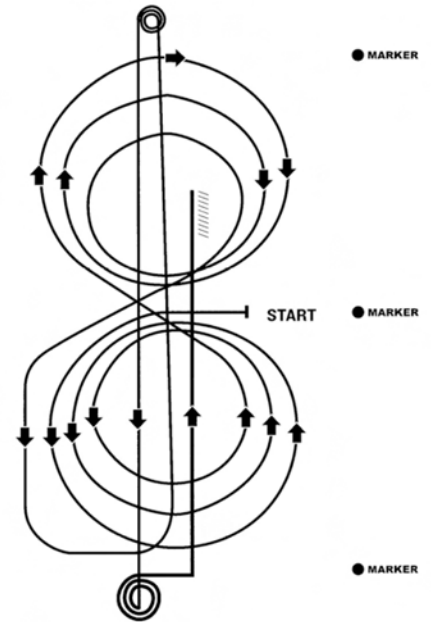

WORKING COW HORSE PATTERN #8

Trot to center of arena, stop. Start pattern facing toward judge.

1. Begin at center of arena. Pick up left lead and complete 3 circles (2 large, fast circles; then 1 small slow circle). Change leads to the right.
2. Complete 3 circles (2 large, fast circles; then 1 small slow circle). Change leads to the left.
3. Continue around end of arena without breaking gait or changing leads, run down center of arena past end marker and come to square sliding stop.
4. Complete 3 1/2 spins to the left.
5. Run down center of arena past end marker and come to a square sliding stop.
6. Complete 3 1/2 spins to the right.
7. Run down center of arena past center marker and come to square sliding stop.
8. Back up at least 10 feet (3.05 m).
9. Hesitate to complete pattern.

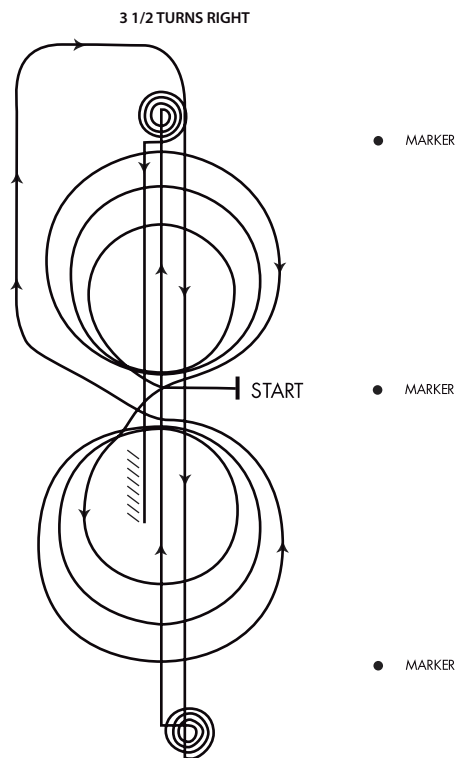

3 1/2 TURNS LEFT

WORKING COW HORSE PATTERN #9

Trot to center of arena, stop. Start pattern facing toward judge.

1. Beginning on the right lead complete 3 circles to the right; the first circle small and slow followed by two large fast circles. Change leads at the center of the arena.
2. Complete 3 circles to the left, the first circle small and slow followed by two large fast circles. Change leads at the center of the arena.
3. Continue around end of arena without breaking gait or changing leads, run down center of arena past end marker, and execute a square sliding stop.
4. Complete 3 1/2 spins to the left.
5. Run down center of arena past end marker, and execute a square sliding stop.
6. Complete 3 1/2 spins to the right.
7. Run down center of arena past center marker, and execute a square sliding stop.
8. Back up at least 10 feet.
9. Hesitate to complete pattern.

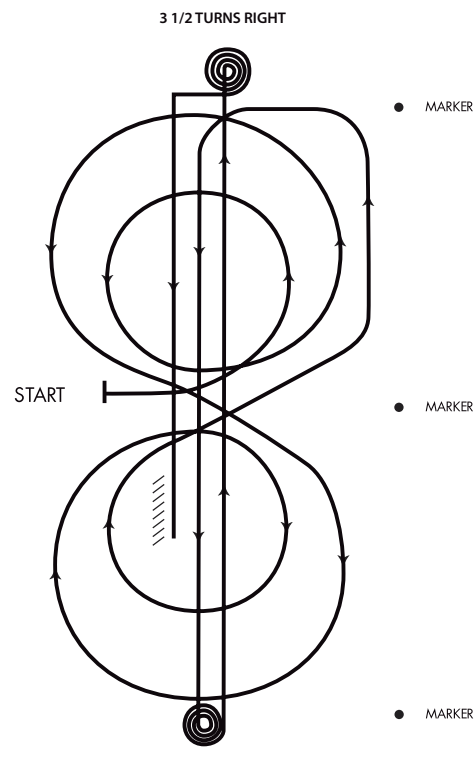

3 1/2 TURNS LEFT

WORKING COW HORSE PATTERN #10

Trot to center of arena, stop. Start pattern facing away from judge.

1. Beginning on the left lead, complete 2 circles to the left; the first circle small and slow, the second circle large and fast. Change leads at the center of the arena.
2. Complete 2 circles to the right; the first circle large and fast, the second circle small and slow. Change leads at the center of arena.
3. Continue around end of arena without breaking gait or changing leads, run down center of arena past end marker, and execute a square sliding stop.
4. Complete 3 1/2 spins to the left.
5. Run down center of arena past end maker, and execute a square sliding stop.
6. Complete 3 1/2 spins to the right.
7. Run down center of arena past center marker, and execute a square sliding stop.
8. Back up at least 10 feet.
9. Hesitate to complete pattern.

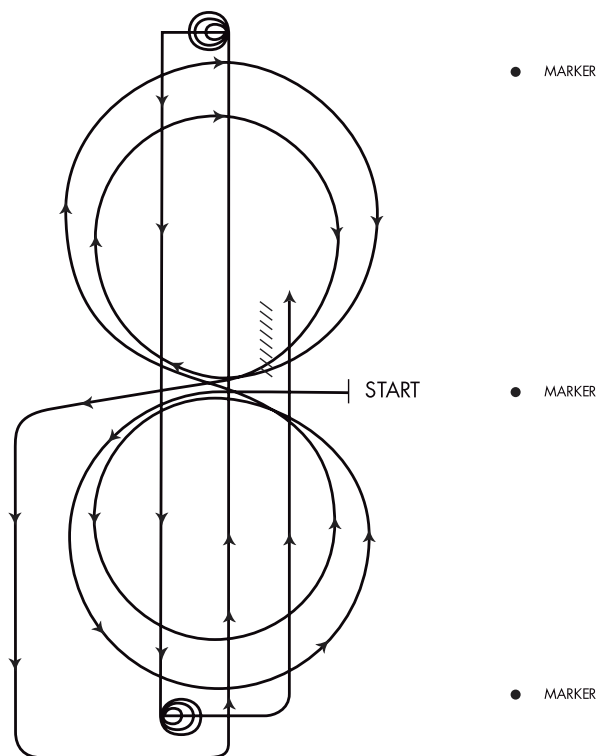

WORKING COW HORSE PATTERN #11

Trot to center of arena, stop. Start pattern facing away from judge.

1. Beginning on the left lead, complete 2 circles to the left; the first circle large and fast, the second circle small and slow. Change leads at the center of the arena.
2. Complete 2 circles to the right; the first circle large and fast, the second circle small and slow. Change leads at the center of arena.
3. Continue around end of arena without breaking gait or changing leads, run down center of arena past end marker, and execute a square sliding stop.
4. Complete 3 1/2 spins to the left.
5. Run down center of arena past end maker, and execute a square sliding stop.
6. Complete 3 1/2 spins to the right.
7. Run down center of arena past center marker, and execute a square sliding stop.
8. Back up at least 10 feet.
9. Hesitate to complete pattern.

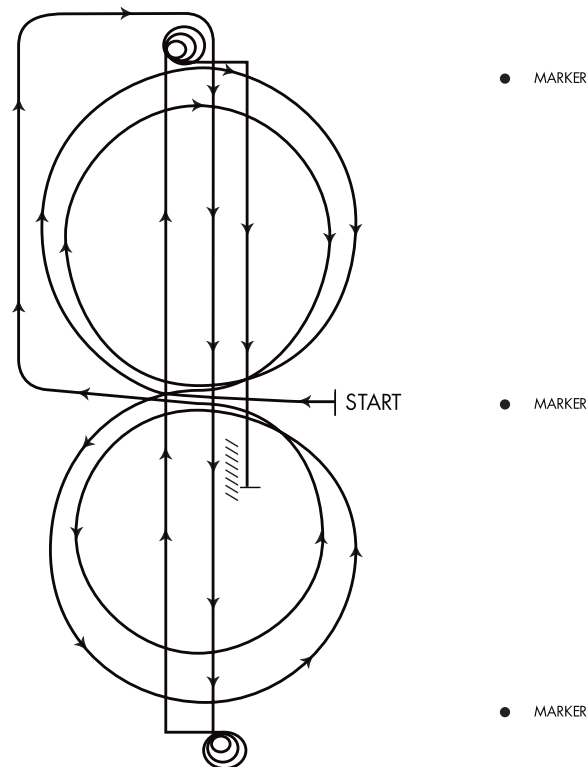

WORKING COW HORSE PATTERN #12

Trot to center of arena, stop. Start pattern facing toward judge.

1. Beginning on the right lead complete 2 circles to the right; the first circle large and fast and the second small and slow. Change leads at the center of the arena.
2. Complete 2 circles to the left, the first circle large and fast and the second small and slow. Change leads at the center of the arena.
3. Continue around end of arena without breaking gait or changing leads, run down center of arena past end marker, and execute a square sliding stop.
4. Complete 2 1/2 spins to the left.
5. Run down center of arena past end marker, and execute a square sliding stop.
6. Complete 2 1/2 spins to the right.
7. Run down center of arena past center marker, and execute a square sliding stop.
8. Back up at least 10 feet.
9. Hesitate to complete pattern.

742. STEER DAUBING

- A. This is a contest judged on time only. Exhibitor may ride one or more horses (except youth may ride **a maximum of two horses**). Cattle may be assigned by draw or cattle may be chute-run and working order will be drawn.
- B. This class will be run very similar to tie-down roping. Time will start when the barrier is sprung and will stop when the exhibitor raises his lance aloft signaling that he has marked the animal.
- C. The horse and exhibitor must start behind a barrier; if the horse breaks the barrier there is an automatic ten-second penalty.
- D. If a horse takes longer than 30 seconds to enter the box after the judge has signaled the course ready, the entry shall be disqualified.
- E. Score line to be determined by arena conditions.
- F. The exhibitor will use a "lance" furnished by the show management, approximately six feet long, padded on one end and soaked in washable paint or white wash. A broken or dropped lance is cause for disqualification from the class.
- G. The steer should have a 16-inch to 20-inch (40.64 – 50.8 cm) circle painted on each side, starting from a point just in front of the hip bone and below the back bone toward the rib cage.
- H. The object of this event is for the exhibitor to daub his lance into one of the circles. One touch allowed per steer. If the daub is inside or on the line, it is considered legal. If any part of the daub is outside the painted circle, no time is awarded.
- I. If a circle is not used, the legal touch area is back of the shoulder and front of the hip bone and on the rib cage, not on the back.
- J. There will be a 35-second time limit on this event, to prevent needless chasing of the steer.
- K. Each exhibitor may daub the steer only once within the 35-second time limit, then must raise his lance aloft, signaling he has marked the animal. More than one mark is a no time.

743. CUTTING

- A. ApHC-approved or -sponsored cutting events will be held in accordance with the National Cutting Horse Association rules for judging. Contact the National Cutting Horse Association, for more information.
- B. The mandatory attire for ApHC cutting shall be long sleeve shirt, pants, boots, cowboy hat. Chaps are optional at ApHC-approved shows and mandatory at ApHC-sponsored shows.
- C. In ApHC-approved cutting events, non-ApHC-registered horses may be used in the arena as turn-back and herd-holder horses. At ApHC-sponsored shows, all horses in the arena must be registered with the ApHC.

744. TEAM PENNING

- A. Within a 90-second time limit, a team of three must cut out from the herd and pen three head of cattle with the same assigned identity number out of a herd of 30. Numbers will be applied to both sides of the animal, high up on its side, with the top near the midline of the animal's back between the shoulder and the hip. The numbers and working order will be drawn by show management prior to the start of the contest. The fastest time wins. A warning will be given to the team working the cattle at 30 seconds prior to the final time being called. In the event a warning is not given, a re-ride may be given at the request of the team. If the team requests a re-ride, the cattle will be settled and a re-ride will be given immediately using the same numbered cattle. The team cannot improve their time in the re-ride over their time in the run in which a warning signal wasn't given. A team may call for time with only one or two assigned cattle penned. However, teams penning three head of cattle place higher than two, and two higher than one regardless of time.
 - 1. If there are twenty (20) or more teams entered in a class, the top ten (10) will come back for the final go. The order of go for the finals will be in the

reverse order of their placing in the first go. Final placing will be based on combined number of cattle penned and time. Placings are determined by the total number of cattle penned and then by time. A team that pens cattle in each go places higher than a team that does not.

- B. All cattle will be bunched on the cattle side of the starting line before the time begins. The line flagman will raise the flag to signal when the arena is ready. Contestants will be given their cattle penning number when the line flagman drops his flag as the nose of the first horse crosses the starting line. Exhibitors are committed once they enter the arena. Any delay will be a disqualification.
- C. To call for time, one rider must break the plane at the opening of the pen with one hand raised. The judge will drop the flag stopping time, once the nose of the first horse has broken the plane and cattle are completely in the pen. If there are any unpenned cattle on the pen side of the start/foul line, time will continue until all unpenned cattle are on the cattle side of the start/foul line. Should an animal escape the pen after time is called for and prior to all unpenned cattle being on the cattle side of the line, the team will be judged a NO TIME. If an animal escapes as a team is calling for time, they will be judged a NO TIME.
- D. As each new team begins a run, there must be three head of cattle per team in the arena. There must always be the same number of cattle in each of the herds used in go-rounds. In the event that more or less than three identical numbers are discovered within a herd, the teams with more or less than three identical numbers must have a rerun at the end of the total go-round. Times for all other teams within such a mis-numbered herd will remain the same. A team calling for time with any wrong numbered cattle in the pen will be judged no time. Contact with cattle by hands, hats, ropes, bats, romal or any other equipment is a disqualification. A team exhibiting any unnecessary roughness will be judged no time. No hazing with whips, hats or ropes allowed. Romals or reins may be swung or popped on chaps.
- E. Fall of horse and/or exhibitor shall not eliminate the entry; however, any attempt by a dismounted exhibitor to work cattle before remounting will result in an automatic disqualification.
- F. In the event a team is given a number that has already been used with a given herd, a rerun must be given immediately using the correct number within that same herd. Should the error be discovered after the herd has been removed from the arena, then the rerun will be given at the end of the total go-round using the same herd.
- G. Once committed to the cattle, the team is completely responsible for their animals. It is a team's responsibility before working the cattle to pull up and call for a judge's decision if, in their opinion, there is an injured or unusable animal in their numbered cattle. Once the cattle are worked, no excuses are accepted. If an animal leaves the arena, either over or through the fence, the team can either be disqualified for unnecessary roughness, or can be given a rerun depending on the judge's decision. If a rerun is given, it must be given at the end of the total go-round. If no fresh cattle are available for reruns, the cattle to be used will be determined by the show management and judge. If more than one rerun is given in any go-round, they will be taken in order of occurrence. If cattle are to be re-used and additional fresh cattle are needed, the used cattle must be mixed with the fresh cattle and renumbered. Every attempt must be made to insure each team works the same number of used and fresh cattle.
- H. A team will be disqualified by the judge for any action he feels to be unnecessary roughness to the cattle or horses, or unsportsmanlike conduct.
 - I. If five or more head of cattle cross the starting line at the same time, that team will be judged no time.
 - J. If for any reason a team does not show after the order of go has been drawn, their cattle number will be drawn in the order the team would have run and the drawn number will not be used in that set of teams. This will avoid changing the order of go for the other contestants.
- K. In the event of a tie affecting the placings, each team will be allowed to pen one numbered animal. Fastest time breaks the tie.

- L. There shall be two flagmen, one at the line and one at the pen and at least two timers. The starting and foul line must be designated by markers located on the arena fence easily viewed by the line judge and the exhibitors.
- M. Course Design for Team Penning:

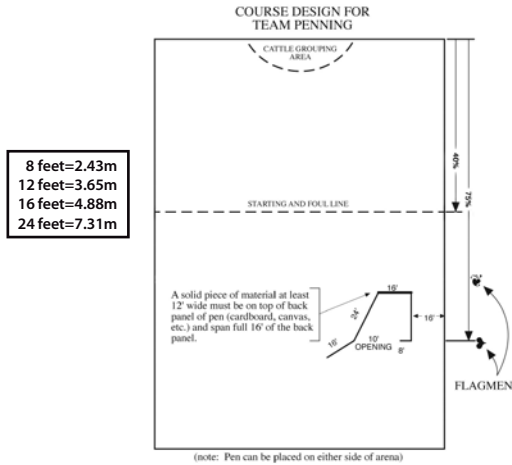

- N. Riders shall not be disqualified for riding two-handed or making hand contact with the horse or saddle.

745. GENERAL RULES FOR ROPING CLASSES

- A. Roping events recognized by the ApHC are:
1. Judged Tie-Down Roping (Non-Pro, Youth, Junior, Senior)
 2. Timed Tie-Down Roping (Non-Pro, Open)
 3. Judged Heading (Non-Pro, Youth, Junior, Senior)
 4. Judged Heeling (Non-Pro, Youth, Junior, Senior)
 5. Timed Heading & Heeling (Non-Pro, Open)
 6. Breakaway Roping (Non-Pro, Youth)
- B. Roper may ride one or more horses. Cattle may be assigned by draw or cattle may be chute-run and working order will be drawn. All changes in working order must be made before any stock for that event is loaded in chutes. After stock is loaded roper must rope in order listed.
- C. Show management has the option of dividing ApHC Timed Tie-Down Roping at their discretion providing it is so stated in the premium list. Classes may be divided into Senior Tie-Down Roping and Junior Tie-Down Roping. A horse shall only be permitted to enter any Timed Tie-Down Roping class once.
- D. Show committee should make every effort to have cattle of equal size and weight.
- E. Barrier neck ropes may be tied with strong or suitable rubber band and should have slide knot on it to insure snug fit around neck. In timed events, there will be a 10-second penalty for breaking or beating the barrier. The barrier will not be considered broken if dropped more than 10 feet (3.05 m) from post. In judged events, breaking the barrier is a fault, not a disqualification and should be judged accordingly.
- F. At shows sponsored or approved by the ApHC, the following procedure is used: The horse and exhibitor that are entered will be considered the entry (which may be either the header or heeler) and will receive a number for that team. Points and placings will be counted on this entry only.
- G. Barrier must be used in all roping events. Electronic barriers are not allowed.
- H. In judged events, a rerun may be given if the animal being roped leaves the arena. In timed events, if calf or steer escapes the arena, field flagman will stop

time. Roper will begin from the chute, lap and tap, adding first time to the additional time required to finish the run.

- I. If in the opinion of the line judge, the exhibitor is fouled by any moving part of the chute, barrier, etc. or in the event of a malfunction of the chute or barrier, ropers shall get their calf or steer back providing exhibitor declares himself by pulling up immediately.
- J. The judges will decide any questions as to catches.
- K. In all roping events the exhibitor shall not attempt to rope the animal until the barrier flag has been dropped. Any attempt by an exhibitor to position his horse behind the barrier enabling the exhibitor to rope the animal without leaving the barrier (box) shall be considered a disqualification.
- L. In tie-down roping classes, if calf is jerked down so that calf is upside down with all four legs in the air at the same time, this will be cause for disqualification.
- M. For all Heading and Heeling events, exhibitors are to stay mounted. When both ropes are dalled and both horses are facing stretched steer, run is completed. The rope must be wrapped around the saddle horn at least one complete turn before it is considered a dally.
 1. Heelers over the age of 50 and women of any age may tie on with the use of a quick release device, rather than dally to the saddle horn.
- N. In timed roping events, if a horse takes longer than thirty seconds to enter the roping box, he will be disqualified. In judged roping events, three refusals into the roping box will be cause for disqualification.
- O. Any unnecessary whipping, jerking of reins, talking, noise making, slapping, jerking of the rope, or any other unnecessary action to induce the horse to perform better, will be considered a fault and scored accordingly.
- P. In judged events, use of two hands shall result in disqualification. Second hand is allowed to adjust reins when the horse is completely stopped but not for maneuvering or positioning the horse.

746. TIMED TIE-DOWN ROPING

- A. Rope must be tied hard and fast; exhibitors must rope calf, dismount, go down rope and throw calf by hand, cross and tie three feet. To qualify as legal tie, there shall be one or more wraps, and a half hitch. If calf is jerked down by horse, it must be allowed to regain its feet and roper must throw calf by hand, cross any three feet and tie with not less than one complete wrap and a half hitch. If roper's hand is on the calf when calf falls, calf is considered thrown by hand. Rope must hold calf until roper gets hand on calf. Tie must hold and three legs remained crossed until passed on by the judge, and roper must not touch the calf after giving finish signal until after the judge has completed his examination. If tie comes loose or calf gets to his feet before the tie has been ruled a fair one, the roper will be marked no time.
- B. In tie-down roping classes, if calf is jerked down so that calf is upside down with all four legs in the air at the same time, this will be cause for disqualification.
- C. Two loops will be permitted. Should the roper miss with both he must retire and no time will be allowed. Catch as catch can but roping calf without releasing loop from hand is not permitted. Jerk lines are not permitted.
- D. If roper intends to throw two loops, he/she must carry two ropes.
- E. There will be a 35-second time limit in open tie-down roping and a 60-second time limit on Youth and Non-Pro tie-down roping. In either case the calf must be roped and tied within the time limit. The timer at the end of the 35-second or 60-second span shall blow a whistle indicating no time. A broken barrier will not count against the time limit.
- F. Rope must be run through a foul rope around horse's neck, or may, at the discretion of the exhibitor, be run through a "keeper." If a keeper is used, it must be attached to the noseband of the tie-down and cannot be attached to the bit or bridle. Exhibitors must adjust rope and reins in a manner that will prevent horses from dragging calf. Exhibitors must receive no assistance of any kind

from the outside. If horse drags calf more than 10 feet (3.05 m) after exhibitor has completed tie, the field judge may stop the horse and the exhibitor will be disqualified. Penalty for such offense can be assessed by the field judge.

- G. The field judge will pass on the tie of calves through use of stop watch; timing six seconds from the time the rope horse takes his first step forward after the roper has remounted. Rope will not be removed from calf and rope must remain slack until field judge has passed on tie. In the event a contestant's catch rope is off a calf, after completion of tie, the six-second time period is to start when roper clears calf.
1. Flagman must watch calf during the six-second period and will stop watch when calf kicks free using the time shown on the watch to determine whether calf was tied long enough to qualify.
 2. Roper will be disqualified for removing rope from calf after signaling for time, until the field judge has passed on the tie.
- H. If a horse takes longer than 30 seconds to enter the box after the judge has signaled the course ready, the entry shall be disqualified.

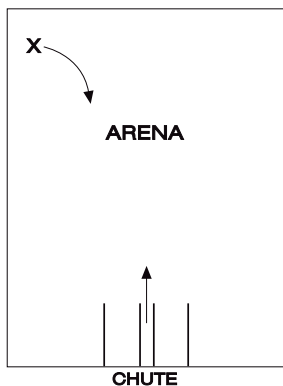

747. JUDGED TIE-DOWN ROPING

- A. The tie-down roping horse must start from behind barrier. The horse will be judged on manners going into the box, behind barrier, scoring, speed to calf, rating calf, stop, working the rope, and its manners while roper is returning to horse after tie has been made. Only the performance of the horse is to be judged. Time is not a factor.
- B. Scoring will be done on the basis of 0-100 with 70 denoting an average performance.
- C. The roper may throw a maximum of two loops and this must be done within a one-minute time limit from time calf leaves the chute. If more than one loop is thrown, the roper may recoil the rope and build the additional loop or may carry a second rope tied to the saddle in which case, this rope must be used for the second loop. If the roper fails to catch, he will retire from the arena with no score. Any catch that holds is legal, but rope must remain on calf until tie is completed and roper has mounted horse.
- D. If calf is jerked down by horse, it must be allowed to regain its feet and roper must throw calf by hand, cross any three feet and tie with not less than one complete wrap and a half hitch. Failure of calf to stay tied until roper has remounted and ridden forward to loosen rope shall disqualify entry. Rope must hold calf until rider rides forward one step. Once the rider has ridden forward one step and loosened the rope the run is complete.
1. If the calf is jerked down so that the calf is upside down with all four legs in the air at the same time, this will be cause for disqualification.
 2. Dragging the calf more than 10 feet (3.05 m) will be cause for disqualification.

- E. Rope must be run through a foul rope around horse's neck, or may, at the discretion of the exhibitor, be run through a "keeper." If a keeper is used, it must be attached to the noseband of the tie-down and cannot be attached to the bit or bridle. No jerk line is permitted.
- F. In tie-down roping classes, only the roper may touch calf while horse is being judged. Roper may dismount from either side and leg or flank the calf.

The following is not part of ApHC rules, but is merely to serve as a guideline.

ELEMENTS OF A TIE-DOWN ROPING RUN

1. Horse should enter the box freely and willingly and back smoothly and quietly into the correct corner.
2. Horse should stand squarely on all four feet while in the box.
 - a. Horse should not squat in any manner.
 - b. Horse should not dance.
3. Horse's attention should be on the front of the chute. He should not be gazing all around. A horse will not be penalized for having its head slightly turned one way or the other. However, if the horse's head is turned excessively to one side, then it will be penalized.
4. When the roper calls for the calf, the horse should run out of the box and not lunge. The smoother and flatter a horse leaves the box, the quicker the roper can get ready to rope.
 - a. Breaking the barrier will be penalized.
 - b. Anticipating the roper calling for the calf will be penalized. The horse moving forward and needing to be reset indicates this.
 - c. Stalling or freezing in the box will be severely penalized.
 - d. Because the calf gets a head start, the horse should leave the box at an angle to intercept the path of the calf as quickly as possible.
5. The horse should get to a "pocket" directly behind the calf. When the horse gets to that pocket, he should "rate" the calf. This means he should run in that pocket at the same speed that the calf is running, making adjustments to his own speed should the calf slow down, speed up or change directions. He should stay in this position until the roper ropes. In a calf run, pocket, rate and rope times are instantaneous. The main thing is that the horse must have speed enough to catch the fastest calf and yet not run by or run over the calf. His job is to help the roper during every aspect of the run.
6. When the roper ropes, the horse should stop hard and straight without any forward movement. The horse should stop on his own when he feels the roper leaving the saddle. Any excessive pulling on the reins by the roper will be penalized. Any premature stopping or scotching will also be penalized.
7. After the calf has been roped, the horse should immediately be prepared to "work the rope". He must keep firm pressure on the rope that is on the calf's neck, enabling the roper to go down the rope to the calf in preparation for flanking and tying the calf. In order to keep this firm pressure the horse may need to back up to tighten the rope between the saddle horn and the calf's neck. When the roper flanks and throws the calf and begins to tie it, the horse must maintain the pressure on the rope without choking the calf and/or dragging it. Overworking the rope is not good because the calf will struggle if it can't breathe, thereby making the roper struggle to tie it. Additionally, if the horse drags the calf too far, it will be cause for disqualification. If a horse underworks the rope, allowing slack between the saddle horn and the calf, he is not doing his job. He is forcing the roper to work alone to get to the calf, flank it, and tie it.
8. The horse's attention should be solely on the calf and the roper.
9. The horse should maintain firm pressure on the rope until the roper remounts and moves the horse forward. He should then stand quietly.

The following is not part of ApHC rules, but is merely to serve as a guideline.

SUGGESTED GUIDELINES FOR SCORING TIE-DOWN ROPING

Box and Barrier

Credit: Up to 2 points

Penalties:

- 1- 2 points - Nervousness
 - a) Entering the box
 - b) Turning around
 - c) Ready position
 - d) Turns head severely
 - e) Squats in the corner
- 2- 5 points - Depending on severity
 - a) Refusing to enter box
 - b) Rearing up in box
 - c) Freezing in the box (refusing to move)
 - d) Broken barrier

Running and Rating

Credit: Up to 3 points

Penalties:

- 1 - 2 points - a) Trouble maintaining position
- 2 - 5 points - a) Setting up or scotching
- 3 - 5 points - a) Running into calf

Stop

Credit: Up to 3 points

Penalties:

- 1 - 3 points
 - a) Using reins to stop horse
 - b) Stopping crooked
- 3 points
 - a) Begins the stop on front end
 - b) Rearing up in stop
 - c) Ducking off badly

Working Rope

Credit: Up to 3 points

Penalties:

- 1 point
 - a) Looking off
- 1 - 3 points
 - a) Failure to continue backing while roper is flanking calf
 - b) Slack in rope
 - c) Dragging calf excessively while tying or while roper returns to horse
 - d) Shying away from roper while remounting
- 3 points
 - a) Rubbing the rope
- 5 points
 - a) Running rope down opposite side of horse's neck.

748. TIMED HEADING & HEELING

- A. Each exhibitor will be allowed to carry only one rope. Each team is allowed as many throws as designated by the judge or show committee. Roping steers without turning loose of the loop will be considered no catch. Roper must dally to stop steer. No tied ropes allowed.
- B. Steer must be standing up when roped by head or heels. Time will be taken when steer is roped, both horses facing steer in line with ropes dallied and tight. Horse's front feet must be on ground and roper should be mounted when time is taken.
- C. Steer must not be handled roughly at any time, and ropers will be disqualified if in the opinion of the field judge they have intentionally done so.

- D. If header accidentally jerks steer off his feet or steer trips or falls, header must not drag steer over approximately eight feet before steer regains his feet or the team will be disqualified.
- E. If the heeler ropes a front foot or feet in the heel loop, this is a foul catch. Neither contestant may remove the front foot or feet from the loop by hand. However, should the front foot or feet come out of the heel loop by the time the field judge drops his flag, time will be counted.
- F. If exhibitor drops loop, loop shall be considered thrown.
- G. In case the field judge flags out a team that still legally has one or more loops coming, the judge may give the same steer back lap and tap, and a five-second penalty will be assessed for each loop already thrown.
- H. Suggested options for judges in Heading & Heeling: Prior to the start of the class, the judge or show committee should decide if they will allow each team two or three loops per run. In either case, the header must throw the first loop; steer must be roped by the head before he can be roped by the heels.
- I. When only two loops are allowed and the header misses the first loop, the team is eliminated. If the header catches and the heeler misses, the team is eliminated. Both must catch with their first loops to receive a time.
- J. When three loops are allowed, the header must still throw the first loop. If the header misses, then either roper may take the second loop. The header may rebuild his loop or the heeler may rope the steer around the head. If this second loop is missed, then the team is eliminated. If the second loop is a catch, then the remaining roper must rope the steer by the heels to receive a time. There will be a 35 second time limit.
- K. There will be only three legal head catches:
 - 1. Around both horns.
 - 2. Half a head.
 - 3. Around the neck.
- L. If honda passes over one horn and the loop over the other, catch is illegal. If rope is in steer's mouth, catch is illegal.
- M. If loop crosses itself in a head catch, it is illegal. This does not include heel catches.
- N. Any heel catch behind both shoulders is legal if rope goes up heels.
 - 1. The steer must be controlled by the header and make a full body turn before the heel loop can be thrown. In the instance where a steer sets up, the steer must be in tow for the heel loop to be legal. Any heel loop thrown in the switch is considered a crossfire and illegal.
- O. One hind foot receives five-second penalty.
- P. Heelers over the age of 50 and women of any age may tie on with the use of a quick release device, rather than dally to the saddle horn.
- Q. If either horse takes longer than 30 seconds to enter the box after the judge has signaled the course ready, the entry shall be disqualified.

749. JUDGED HEADING

- A. The manners of the horse shall be judged at all times.
- B. Only the heading horse shall be started and judged behind a barrier. The heading horse shall be judged going into the box, behind the barrier, on the rate of speed, ability of horse to rate, check, set and turn the steer into position for heeler and turn and face the steer until the rope is tight. Only the performance of the horse is to be judged. Time is not a factor.
- C. Scoring will be done on the basis of 0-100 with 70 denoting an average performance.
- D. Riders are to stay mounted, and when both ropes are dallied and both horses are facing the stretched steer, the run is completed. The rope must be wrapped around the saddle horn at least one (1) complete turn before it is considered a dally.
- E. When the heading horse is being judged, the roper may throw a maximum of two loops within a one-minute time limit. If roper fails to catch with either loop, they are to retire from the arena with no score. The exhibitor not being

judged may use a maximum of two loops to make the catch within a one-minute time limit. If a header or heeler drops his rope, the contestant being judged will receive no score.

- F. There will be only three legal head catches:
1. Around both horns.
 2. Half a head.
 3. Around the neck.
- G. The following catches are illegal: honda passes over one horn and loops the other, loop crosses itself on the head catch or loop is in steer's mouth.
- H. Any catch by the heeler not being judged must be a legal catch defined as a catch which holds from behind the steer's shoulder and back, around the flank, or on one or both heels, but not by the tail only.
1. The steer must be controlled by the header and make a full body turn before the heel loop can be thrown. In the instance where a steer sets up, the steer must be in tow for the heel loop to be legal. Any heel loop thrown in the switch is considered a crossfire and illegal.
- I. Heelers over the age of 50 and women of any age may tie on with the use of a quick release device, rather than dally to the saddle horn.

The following is not part of ApHC rules, but is merely to serve as a guideline.

ELEMENTS OF A HEADING RUN

1. Horse should enter the box freely and willingly and back smoothly and quietly into the correct corner.
2. Horse should stand squarely on all four feet while in the box.
 - a. Horse should not squat in any manner.
 - b. Horse should not dance.
3. Horse's attention should be on the front of the chute. He should not be gazing all around. A horse will not be penalized for having its head slightly turned one way or the other. However, if the horse's head is turned excessively to one side, then it will be penalized.
4. When the roper calls for the steer, the horse should run out of the box and not lunge. The smoother and flatter a horse leaves, the quicker the header can get ready to rope.
 - a. Breaking the barrier will be penalized.
 - b. Anticipating the roper calling for the steer will be penalized. The horse moving forward and needing to be reset indicates this.
 - c. Stalling or freezing in the box will be severely penalized.
 - d. Because the steer gets a head start, the horse should leave the box at an angle to intercept the path of the steer as quickly as possible.
5. On leaving the box, the horse should get to a "pocket" slightly to the left and behind the steer. When the horse gets to that pocket, he should "rate" the steer. He should remain in that pocket no matter where the steer goes or at what speed.
 - a. When the header ropes the steer, the heading horse should have the athletic ability and strength to slow the steer down and begin to move sideways without jerking the steer or turning at a 90 degree angle.
 - b. The horse will be penalized for dropping his left shoulder and going hard left with the steer. The header must have the time to get slack out of his loop and dally.
 - c. The pace that a steer is taken off is very important. If the pace is too slow, the steer will trot which makes catching two feet more difficult. Likewise, if the steer is taken off too fast, there will be no rhythm to the steer's feet making it difficult to heel. When a steer is taken off at an optimum pace, the steer will "hop", and there will be a rhythm with the steer's hind feet hitting the ground at the same time. A good heading horse must also be able to handle a steer that drags. When a steer drags, the heading horse must exhibit enough strength to "get the steer out of the ground", thereby giving the heeler opportunity to rope the heels.

- d. The horse will be penalized for making two left turns. This causes the heeler to have to cover too much ground to get a throw at the heels.
6. When the horse has the steer in position for the heeler to rope, he should then be prepared to "face" as soon as the heeler's rope comes tight around the hind legs of the steer.
- a. If a heading horse faces too soon, the result may be the heeler loses one or both heels because there was slack left in the rope.
 - b. If the heading horse faces too late, he could jerk the rope out of the heeler's hand or cause injury to the steer.

The following is not part of ApHC rules, but is merely to serve as a guideline.

SUGGESTED GUIDELINES FOR SCORING HEADING

Box and Barrier

Credit: Up to 2 points

Penalties:

1-2 points - Nervousness

- a) Entering the box
- b) Turning around
- c) Ready position
- d) Turns head severely
- e) Squats in the corner

2- 5 points - Depending on severity

- a) Refusing to enter box
- b) Rearing up in box
- c) Freezing in the box (refusing to move)
- d) Broken barrier

Running and Rating

Credit: Up to 3 points

Penalties:

2 points

- a) Incorrect position
- b) Does not rate
- c) Does not run to steer
- d) Gets out run

3 - 5 points

- a) Ducking off
- b) Setting up or scotching
- c) Running into steer

Setting and Handling

Credit: Up to 4 points

Penalties:

1 - 2 points

- a) Changing speed leading the steer
- b) Lunging while pulling the steer
- c) Pulling steer with shoulders

8 points

- a) Refusing to pull

Facing

Credit: Up to 2 points

Penalties:

1 - 2 points

- a) Failure to face completely
- b) Rearing while facing

5 points

- a) Refusal to face

750. JUDGED HEELING

- A. The manners of the horse shall be judged at all times.
- B. The heeling horse shall be judged going into the box, in the box, on ease of manner in which he turns and prepares for heeler's position to throw loops, set and stop steer while holding rope tight in preparation for header's facing. Only the performance of the horse is to be judged. Time is not a factor.
- C. Riders are to stay mounted, and when both ropes are dalled and both horses are facing the stretched steer, the run is completed. The rope must be wrapped around the saddle horn at least one (1) complete turn before it is considered a dally. This must be completed within a one-minute time limit, or the exhibitor shall retire from the arena with no score.
- D. Scoring will be done on the basis of 0-100 with 70 denoting an average performance.
- E. The heeler may use a maximum of two loops to make the catch.
- F. All exhibitors in a class are required to compete using the same class procedures. Show management shall inform exhibitors concerning which procedure will be used by posting notification at least one hour prior to the class. At ApHC-approved shows only, class must be conducted using one of the following procedures:
 1. A head loop may be placed on the steer's head or horns before the animal leaves the chute. The header must let the steer pass the marker halfway down the arena before turning the steer back. The heeler may use a maximum of two loops to make the catch. Or,
 2. The header may throw a maximum of two loops. If the header fails to catch with either loop, they are to retire from the arena with no score.
- G. At ApHC-sponsored shows:
 1. The header may throw a maximum of two loops. If the header fails to catch with either loop, they are to retire from the arena with no score.
- H. If a header or heeler drops his rope, the contestant being judged will receive no score.
 1. The steer must be controlled by the header and make a full body turn before the heel loop can be thrown. In the instance where a steer sets up, the steer must be in tow for the heel loop to be legal. Any heel loop thrown in the switch is considered a crossfire and illegal.
- I. The heel catch is defined as a catch which holds from behind the steer's shoulder and back, around the flank, or on one or both heels, but not by the tail only.
- J. Any catch made by the header not being judged must be a legal catch defined as a catch that is around both horns, half-head or around the neck. The following catches are illegal: honda passes over one horn and loops the other, loop crosses itself on the head catch or loop is in steer's mouth.
- K. Heelers over the age of 50 and women of any age may tie on with the use of a quick release device, rather than dally to the saddle horn.

The following is not part of ApHC rules, but is merely to serve as a guideline.

ELEMENTS OF A HEELING RUN

1. Horse should enter the box freely and willingly and back smoothly and quietly into the correct corner.
2. Horse should stand squarely on all four feet while in the box.
 - a. Horse should not squat in any manner.
 - b. Horse should not dance.
3. Horse's attention should be on the front of the chute. He should not be gazing all around. A horse will not be penalized for having its head slightly turned one way or the other. However, if the horse's head is turned excessively to one side, then it will be penalized.
4. Since the heeling horse does not initiate the run, he reacts more than acts. The heeling horse should not move until the steer moves. Again, the heeling horse should run out of the box and not lunge. In a sense, the heeling horse

can break the barrier, too. Part of the heeling horse's job is to keep the steer straight out of the chute. If the horse leaves the box too early, this may cause the steer to go left making it difficult for the header to get into position. Leaving too late allows the steer to go to the right fence making a difficult throw for the header.

- a. The heeling horse should also get to a "pocket" that is 8-10 feet (2.44–3.0 m) to the right of the steer. The heeling horse's head should be even with the flank or hip of the steer and no farther back than the tail. This is called "shaping" the steer to keep it from drifting to the right fence. The ideal "shape" will be a steer that goes down the center of the arena or slightly left.
 - b. The heeling horse should be prepared to react the instant the steer is roped around the horns and started left.
 - c. A heeling horse should be penalized for cutting in too soon to the left causing rider to check horses and gets back into position. This is called "coming in too soon".
 - d. A heeling horse will also be penalized for running by the steer causing the rider to hold his loop and get back into position. This is called "running by a steer".
 - e. The ideal time for a heeler to make a throw is the first or second hop or stride after the steer changes direction. Therefore, the heeling horse must be athletic enough and quick enough to be directly behind the steer when it turns left.
5. When the proper roping position is reached and the heeler makes his throw, the horse must now be in position to stop and stop hard. By stopping hard, the horse allows slack to be taken out of the rope quicker. This allows for a faster time and for the heeler to rope two feet more often.
- a. At the finish of the run, the heeling horse should not give ground or in any way move forward until the heeler releases his dally and allows the horse to walk forward. The heeling horse will not be penalized for moving forward if the heading horse does not face properly.

The following is not part of ApHC rules, but is merely to serve as a guideline.

SUGGESTED GUIDELINES FOR SCORING HEELING

Box

Credit: Up to 2 points

Penalties:

1 - 2 points - Nervousness

- a) Entering the box
- b) Turning around
- c) Ready position
- d) Turns head severely
- e) Squats in the corner

2- 5 points - Depending on severity

- a) Refusing to enter box
- b) Rearing up in box
- c) Freezing in the box (refusing to move)
- d) Broken barrier

1 – 3 points

- a) If the header breaks the barrier, assess penalty depending on the severity of infraction.

Running, Rating, Stopping

Credit: Up to 3 points on each portion of the run

Penalties:

1 - 3 points

- a) Failure to be in correct lead before horse moves into position on steer
- b) Excessive use of reins to stop the horse

2 points

- a) Getting out late
- b) Failure to reach steer before the header has roped and turned the steer

2 - 4 points

- a) Stopping on front end
- b) Dribbling to a stop
- c) Bouncing up out of stop
- d) Sucking backward out of stop
- e) Shying sideways as roper dallies
- f) Drops shoulder and ducks straight into steer
- g) Hits the steer

3 - 5 points

- a) Assuming position on wrong side of steer

751. BREAKAWAY ROPING

- A. This is a timed event. This event will be performed under the same general rules and conditions as Tie-Down Roping with the exceptions that the roper neither dismounts nor ties the calf.
- B. Barrier requirements are the same as Tie-Down Roping. Horse must start from behind a barrier. A 10-second penalty will be added to the time for breaking the barrier. Calves must be used.
- C. The exhibitor shall use a regulation loop with the rope tied to the saddle horn by a piece of string in such a manner as to allow rope to be released from the horn when the calf reaches the end of the rope.
- D. The exhibitor will be allowed a maximum of two loops and a one-minute time limit. Should the roper desire to use a second loop, s/he may recoil the rope and build the additional loop or may carry a second rope tied to the saddle to be used for the second loop.
- E. The loop must leave the roper's hand, then catch as catch can, with any catch considered legal, as long as the loop has first passed over the calf's head. The field flagman shall rule on the legality of a catch.
- F. Time will be called from the drop of a barrier to the break of the string attached to the saddle horn. To aid the field flagman in calling time, a visible cloth should be attached to the end of the rope the exhibitor carries.
- G. The string must be broken from the saddle horn by the jerk of the rope securing the calf. The contestant shall receive no time should he break the rope from the horn by hand or touch the rope or string after the catch is made. If the rope dallies or will not break free when the calf reaches the end of it, the contestant will receive no time.
- H. The Show Committee and/or Show Management may determine whether the calves will be (a) chute run, or (b) drawn for order.
- I. The judge should be mounted on a horse and serve as field flagman to judge when the string breaks and time stops.
- J. If a horse takes longer than 30 seconds to enter the box after the judge has signaled the course ready, the entry shall be disqualified.

Rules 752-759 are not assigned.

SPECIALTY CLASSES

760. HERITAGE CLASS

- A. To be judged on authenticity of trappings and equipment, attire of exhibitor, markings and colorful qualities of horse—the overall picture including the exhibitor's verbal presentation is to be considered.
 1. Narration of the costume by the exhibitor is limited to no more than 90 seconds.
- B. The judge, at his/her discretion, can dismiss entries that are, in their opinion, frivolous, not in keeping with the respect that the ApHC encourages for the history and heritage of our breed, or entries that violate the intent of Rule 609.A.2.
- C. Since the Appaloosa is rich in history, this class is designed to vividly portray some of this history. The Heritage class will be divided in the following two classes: Men's Heritage class (Warriors) and Ladies' Heritage class. Men's and Ladies' Heritage may be combined at regional shows at the discretion of show management only with the unanimous consent of all exhibitors involved in the classes in question. Costumes other than Native American costumes may be used. The costumes may depict the various stages of Appaloosa history such as Chinese emperors, kings, nobles, Spanish conquistadores, fur trappers, buffalo hunters, missionaries or other depictions of Appaloosa history.
- D. There shall be only one exhibitor and one horse allowed per entry. Exhibitors will not be permitted to use a travois in the Heritage class for safety reasons.
- E. The class shall be worked at a walk and jog only, on the rail, both directions of the ring. The judge will then go through the line evaluating each entry and judging authenticity of the entries.
- F. Any exhibitor not having his mount under sufficient control shall be dismissed from the ring and shall be disqualified from the class.
- G. Native American personal appointments: Men and boys shall dress as American Indian (Native American) men being chiefs or warriors braves only. Youth boys should be dressed according to their age. Women and girls shall dress as American Indian (Native American) women and/or girls or princesses only.
- H. Tack Appointments: Horses are to be shown in authentic period trappings and equipment with a bridle, hackamore, mouth rope or other suitable head stall which will enable the exhibitor to have full control of his horse. Reference to "hackamore" in this class shall mean that the horse will be ridden only with a rawhide braided or leather braided or rope bosal. No wire curbs, regardless of how padded or taped, or no chin strap narrower than one-half inch will be permitted. Curb chains are permissible, but must meet the approval of the judge and must be at least one-half inch in width, lying flat against the jaw of the horse.
- I. Prohibited Appointments: Travois, hackamore bits, mechanical hackamores. Use of prohibited appointments is cause for disqualification of the entry from the class. It is the responsibility of the exhibitor who chooses to use feathers in any portion of the Heritage class to be aware of US Federal Laws including the Migratory Bird Act, the Bald and Golden Eagle Protection Act, and the Endangered Species Act.
- J. Paintings and markings of American Indian (Native American) significance shall be permitted on the horse in the Heritage class if the exhibitor so desires.
- K. Heritage exhibitors are allowed to ride two-handed.

Note: For further information regarding authentic period Native American costumes see COSTUME BROCHURE published by the ApHC and EXHIBITORS & JUDGES GUIDE FOR AMERICAN INDIAN COSTUME CLASSES by Jack R. Williams.

761. BUCKBOARD DRIVING

- A. The Buckboard class is designed to depict the early American or Frontier age of which the Appaloosa was a part. Further, the class shall depict the usefulness of the Appaloosa as a family horse used for pleasure driving. The entry shall be limited to not more than four people riding in the vehicle. The class will be judged on authenticity of equipment, attire of exhibitors, markings and colorful qualities of horses - the overall picture and presentation to be considered.
- B. Extremely high action will be severely penalized by the judge. Entries that do not conform to class specifications shall be eliminated.
- C. Handlers will be permitted in the arena during lineup.
- D. Either one or two horses to be shown in harness as a pleasure driving horse to a four-wheel vehicle. The type of vehicle shall be optional providing it portrays an Early American or Frontier mode of transportation. All vehicles shall be of good appearance and stability.
- E. The Buckboard Driving class will be judged on performance, and overall presentation of the horse, suitability of vehicle and trappings, driver, exhibitor, and handler to be dressed to fit time period depicted.
- F. To be shown at a flat-footed walk, a slow trot, and a fast trot (extreme speed to be penalized). Horses must walk both directions of the ring. Horses must stand quietly and back readily. Horses are not to be stretched on the line.
- G. Horses to be penalized for pulling on the bits, tossing of head, breaking stride, going sideways and excessive switching of tail. If team is entered, consideration shall be given to the uniformity as a well-matched pair.
- H. PERSONAL APPOINTMENTS: The attire of the driver, exhibitors, and handler shall be optional. However, the entry should keep in mind the Early American or Frontier theme when choosing the attire. Originality of attire shall be given consideration.
- I. TACK APPOINTMENTS: Type of harness is optional. A snaffle bit with overcheck or a snaffle bit or Liverpool bit with side check will be considered proper in driving class. Bridles with blinkers and/or overcheck are optional. A spoon crupper is prohibited. All equipment to be clean, neat and in sound condition.

762. LADIES' SIDE SADDLE

- A. Show management has the option of conducting this class as a Western Side Saddle Pleasure, an English Side Saddle Pleasure or as a combined Western-English Side Saddle Pleasure class. The Side Saddle class, either western or English (hunt seat or saddle seat) shall be a specialty class and the use of a side saddle will not be permitted in any class except classes designated in the premium as specifically Side Saddle classes.
- B. In combined English-Western Side Saddle classes, horses to be shown at walk, jog-trot or trot, and lope or canter, as appropriate.
 1. Western gaits:
 - a. Walk: True and flat-footed.
 - b. Jog-Trot: Square, slow and easy (a ground covering gait).
 - c. Lope: Smooth and easy on both leads with the ability to push on if required to do so.
 2. English gaits
 - a. Walk: True and flat-footed for pleasure classes.
 - b. Trot: Brisk, smart, cadenced and balanced without loss of form. An extended trot may be called for at the judge's option, but the judge may not call for a canter from a trot.
 - c. Canter: Smooth, collected and straight on both leads with the ability to push on if so required into a hand gallop.

- C. Horses to back easily and stand quietly. Horses required to back at judge's option. Entries shall be penalized for being on the wrong lead at the lope. Horses are to be reversed at the walk or trot at the discretion of the judge, but horses shall not be asked to reverse at the lope. It is the judge's option to require an exhibitor to extend the walk, trot or lope. Exhibitors shall not be required to dismount. Horses to be shown at a walk, trot and canter both ways of the ring. It is the judge's option to require an exhibitor to extend any gait, to back easily, and stand quietly. Light contact with horse's mouth is recommended. Horse must be brought to a flat-footed walk before changing gaits. The judge may ask the group to halt and stand quietly on a free rein (loosened rein). Horses should be obedient, alert, responsive and move freely: They need not be eliminated for slight errors.
NOTE: For more information on side saddle classes, contact the International Side Saddle Association.

Rules 763-769 are not assigned.

770. ENGLISH PERFORMANCE

A. EQUIPMENT.

1. In all English classes, an English snaffle (no shank - conventional O-ring, egg-butt, D-ring or full cheek snaffle with bit keepers), kimberwick, pelham and/or a double bridle consisting of two bits - a curb or weymouth and a snaffle or bradoon (all with two reins, no convertor strap), all with cavesson nosebands and plain leather brow bands must be used. The inside circumference of the ring shall be no smaller than 2" (5.08 cm) and no larger than 4" (10.16 cm). On all snaffle bits, the inside circumference of the ring must be free of rein, curb or headstall attachments which would provide leverage.
2. In reference to mouthpieces, nothing may protrude above or below the mouthpiece (bar) such as extensions or prongs (See Unacceptable Bits). Mouthpieces may be two or three pieces. On broken mouthpieces only, connecting rings of 1 1/4" (3.17 cm) or less in diameter or a connecting flat bar 3/8" to 3/4" (.95 to 1.9 cm) (measured top to bottom with a maximum length of 2" (5.08 cm)) which lie flat in the horse's mouth are acceptable. All mouthpieces must be a minimum of 5/16" (.79 cm) in diameter with snaffles to be measured 1" (2.54 cm) in from the cheek with a gradual decrease to the center of the snaffle. Mouthpiece may be inlaid, but smooth or latex wrapped. Smooth, round, oval or egg-shaped, slow twist, corkscrew, single twisted wire, double twisted wire mouthpieces and straight bar or solid mouthpieces with a maximum port no higher than 1 1/2" (3.81 cm) are allowed.
3. In English classes designated for two year olds, references to an acceptable snaffle bit mean the use of a conventional O-ring, egg-butt or D-ring with a ring no smaller than 2 inches (5.08 cm) and no larger than 4 inches (10.16 cm). The inside circumference of the ring must be free of rein, curb or headstall attachments which would provide leverage. The mouthpiece should be round, oval or egg-shaped, smooth, and no mouthpieces can be wrapped in metal. Bit may be inlaid, smooth or latex wrapped. No untwisted square-stock steel can be used. The bars must be a minimum of 5/16 inch (.79 cm) in diameter, measured 1 inch (2.54 cm) in from the cheek with a gradual decrease to the center of the snaffle. (See Figure 1). Slow twists, corkscrew, double and single twisted wires may be used if they are a minimum of 5/16 inch (.79 cm) in diameter to be measured 1 inch in from the cheek or ring. No bit with leverage (such as kimberwicks or pelhams) or any bit with shanks, a curb chain, or reins attached to the bit may be used.

- a. Notwithstanding the above, the mouthpiece may be two or three pieces. See A.2. above for requirements regarding three-piece mouthpieces.
4. When a curb bit is used, a curb strap or curb chain is required, but must meet the approval of the judge, be at least 1/2" (1.27 cm) width and lie flat against the jaw of the horse.
5. In jumping classes only, mechanical hackamores are allowed.
6. Bits of any style (pelham, snaffle, kimberwick) featuring cathedral, fishback or donut mouthpieces; prongs, edges or rough, sharp material shall be cause for elimination.
7. A bit cannot be physically or mechanically altered to increase the severity of its use and may be eliminated at the discretion of the judge. Spring-loaded bits are approved as long as they meet all bit specifications outlined in this handbook.
8. A dropped noseband is prohibited in all English classes except jumping. A dropped noseband shall be interpreted as a cavesson and/or noseband which is fastened below the bit or mouthpiece.
9. An exhibitor may be required by the judge to remove or alter any piece of equipment which, in his opinion, would tend to give a horse or exhibitor an unfair advantage.
10. Saddles must be heavy, plain, leather skirted (of hunt seat type) or forward (of hunt seat type) may have suede seat and/or suede inset on skirt and either leather or cloth lining. Either, leather, web, cord, neoprene or linen girths are permitted.
11. Saddle pads should fit size and shape of saddle, except when necessary to accommodate numbers on both sides for which a square pad or suitable attachment maybe used. Saddle pads and attachments shall be white or neutral color with no decorative trim or logos and without ornament.

B. OPTIONAL EQUIPMENT:

1. Spurs of the unroweled type.
2. Crops or bats.
3. Gloves.
4. English breast plate.
5. Braiding of mane or tail in hunt style.
6. Martingales in working hunter, jumping or equitation over fences.
7. Boots in jumping only.
8. Leg wraps in jumping only.
9. Loose curb strap
10. A standard sliding, rundown or skid boot on the rear fetlocks and splint boots or bell boots on the front legs are optional appointments in jumping. The use of gel-casts or any other hard type casts will not be permitted. In the event of injury, the judge may permit a protective bandage.

C. PROHIBITED EQUIPMENT:

1. Draw reins except in open jumping.
2. Roweled spurs.
3. Martingales except in working hunter, jumping or equitation over fences.
4. Boots of any description, except in open jumping.
5. Leg wraps, except in jumping.
6. Whips other than crops or bats.

ACCEPTABLE ENGLISH BITS

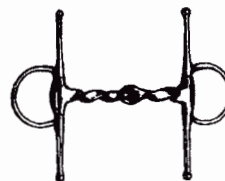

Slow Twist

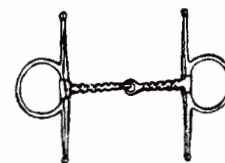

Corkscrew

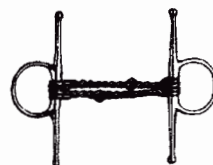

Double Twisted Wire



Single Twisted Wire

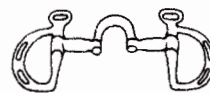

Correction Bit



Snaffle Bit with
Connecting Flat Bar

UNACCEPTABLE ENGLISH BITS



Excessive Port

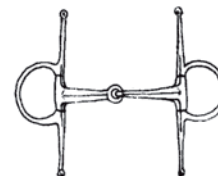

Triangular Mouth

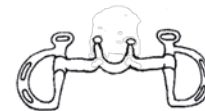

Prong Bits

SOME ACCEPTABLE SNAFFLE BITS

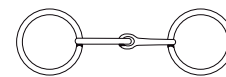

O-Ring Snaffle Bit



Eggbutt Snaffle Bit

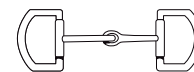

D-Ring Snaffle Bit

FIGURE #1

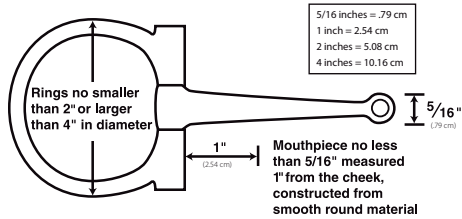

D. ATTIRE

1. Exhibitors should wear coats of any tweed or melton for hunting (conservative wash jackets in season), breeches of traditional shades (or jodhpurs), high English boots or jodhpur shoes. Dark or conservative hunting cap is mandatory. Shirt shall be conservative in color. Stock tie or choker is required. Hair must be neat and contained (as in a net or braid). Judges must penalize exhibitors who do not conform.
2. Protective Headgear.
 - a. Effective January 1, 1993, all exhibitors 18 years old and under riding in all over fence classes including Hunter Hack must wear properly fitting protective headgear passing applicable ASTM (American Society for Testing and Materials) standards while riding in the designated schooling exercise areas, the show ring and while jumping anywhere on the competition grounds. Harness must be secured and properly fitted. Any exhibitor violating this rule at anytime must immediately be prohibited from further riding until such headgear is properly in place.
 - b. The ApHC strongly encourages all exhibitors, regardless of age, to wear protective headgear passing or surpassing current applicable ASTM standards with harness secured while riding anywhere on the competition grounds including while practicing, schooling, and/or showing. It is the responsibility of the exhibitor, or parent or guardian or trainer of the junior exhibitor to see that the headgear worn by the junior exhibitor complies with appropriate safety standards for protective headgear intended for equestrian use, and is properly fitted and in good condition. The ApHC, Show Committees, and Licensed Officials are not responsible for checking headgear worn by the junior exhibitor for compliance with these rules.
 - c. ApHC makes no representation or warranty, express or implied, about any protective headgear, and cautions exhibitors that death or serious injury may result despite wearing such headgear as all equestrian sports involve inherent dangerous risks and as no helmet can protect against all foreseeable injuries.
- E. Under no conditions may Hunt Seat and Saddle Seat classes be combined. They may be offered only as separate open, non-pro or youth classes.
- F. Traditionally braided manes are recommended in all English classes. However, the absence of a braided mane shall not constitute disqualification.
- G. For requirements on exhibitor numbers, see Rule 711.M.

H. ENGLISH GAITS:

1. WALK: Forward working walk, rhythmical and flat-footed; extremely slow, or "jiggy" walk to be penalized.
2. TROT: Long, low, ground-covering, cadenced and balanced strides. Smoothness more essential than speed. Extreme speed to be penalized. Excessive knee action to be penalized.
3. CANTER: Smooth, free moving, relaxed and straight on both leads. The stride should be suitable to cover ground following hounds. Over-collected, four-beat canter to be penalized. Excessive speed to be penalized.
4. HAND GALLOP: Should be a definite lengthening of the stride with a noticeable difference in speed. The horse should be under control at all times and be able to pull up (not a sliding stop).

771. PLEASURE DRIVING

- A. Horses to be shown harnessed to a modern pleasure-type one horse cart. Either a two-(Informal) or four-wheeled (Formal) cart may be used. All carts must be equipped with 24" (60.96 cm) through 48" (121.92 cm) cart wheels. Two wheeled carts must be basket-type and four-wheeled carts must be designed with a floor. No stirrup-type carts, chariots or racing sulkies will be allowed. No more than one person shall be permitted in a two-wheeled cart and no more than two persons shall be permitted in a four-wheeled cart while the horse is being exhibited. No pets are allowed. Dash and blanket cover are optional. When entries warrant, i.e., when each class will count for points, class may be split into: Formal Driving (four-wheeled vehicles) and Pleasure Driving (Two-wheeled vehicles).
- B. After all entries have finished their ring work and are lined up waiting to demonstrate the back, headers may quietly enter the arena and position themselves squarely 2 to 3 feet (60.69 to 91.44 cm) in front of the horse's head. Headers shall stand still with hands behind their back. Should it become necessary to restrain a horse prior to the completion of judging, the judge shall penalize that entry. Judges shall also penalize an entry whose header disturbs or distracts any horse. Headers shall be neatly dressed in western or English attire.
 1. In driving classes, the number must be displayed on both sides of the vehicle shafts.
- C. Exhibitors to dress conservatively and neatly. Dress should conform to the type of vehicle, i.e., casual or sporty attire for a sport or natural finish vehicle, formal attire for a more formal vehicle.
 1. Gentlemen must wear a coat, hat and tie.
 2. Ladies must wear a conservative dress, tailored suit or slacks and a hat. Floppy brimmed hats are not permitted or acceptable. If a short dress or suit is worn, a lap robe is required.
 3. Exhibitors may wear rainwear or inclement weather apparel when showing outside if weather conditions require.
- D. A pleasure driving horse should carry himself in a natural balanced position with a relaxed head and neck. His poll should be level with, or slightly above the level of the withers.
 1. Maximum credit should be given to a horse that moves straight, with free movement, manners and a bright expression.
 2. The horse shall be severely penalized if:
 - a. he carries his head behind the vertical,
 - b. he is overflexed,
 - c. is excessively nosed-out,
 - d. if the poll is below the withers.
 3. Horses to be penalized for pulling on the bit, tossing of head, breaking stride, going sideways and excessive switching of the tail.
- E. Horses shall enter the ring to the right at a normal trot. Each horse shall then be exhibited at the following gaits:
 1. Normal walk,
 2. Normal trot (Park gait),
 3. Extended trot (Road gait). Extreme speed and excessive animation will be penalized.
- F. Each horse shall demonstrate each of such gaits, in both directions of the ring, and at the direction of the ring steward. Such change of directions shall be accomplished by the horse crossing the show ring while walking or in normal trot only. Each horse shall also be required to demonstrate its ability to back readily and stand quietly.
- G. Equipment to be used shall include a whip suitable to the cart, light horse breast collar harness to include surcingle with shaft tie downs or quick hitch and crupper and standard bridle with acceptable snaffle or curb bit. If a curb bit is used, the chain must be at least one-half inch (1.27 cm) in width, must be flat against the jaw of the horse and must meet with the judge's approval. Judge to inspect equipment and vehicle prior to entering the arena. Judge must disqualify unsafe (broken or damaged) harness or vehicle.

- H. Optional equipment: Blinders, overcheck or check reins, breeching or thimbles, running martingales, cavesson noseband.
- I. Prohibited equipment:
 1. Wire curbs, regardless of how padded or covered.
- J. Placings for the class shall be determined by judging each horse on the following basis:
 1. 70% on performance, manners and way of going.
 2. 20% on the condition and fit of harness and vehicle.
 3. 10% on neatness of attire.

772. HUNTER UNDER SADDLE

- A. Hunters Under Saddle should be suitable to purpose. They should move in a long low frame and be able to lengthen their stride and cover ground, as in traversing hunt country following hounds. They should be obedient, alert and responsive to their exhibitors. Quick, short strides should be penalized. Horses which move in an artificial frame and are overflexed and behind the bit should also be penalized. Judges should emphasize free movement and manners.
- B. Horses to be shown at a walk, trot and canter both ways of the ring. Horses should back easily and stand quietly. May be asked to extend the trot.
 1. At the option of the judge, all or just the top eight horses may be required to hand gallop, one or both ways of the ring. Never more than twelve horses to hand gallop at one time. At the hand gallop, the judge may ask group to halt and stand quietly on a free rein (loosened rein).
 2. Horses may be asked to canter from the flat-footed walk or the trot at the judge's discretion.
- C. The horse is to be judged on performance, manners, conformation, quality and substance.
- D. Exhibitor shall not be required to dismount except in the event judge wishes to check equipment.
- E. Judge may ask for additional work of the same nature from any horse. He is not to ask for work other than that listed above.
- F. Horses and equipment are subject to examination by the judge(s).
- G. Faults, to be scored according to severity:
 1. Quick, short or vertical strides.
 2. Being on the wrong lead and/or wrong diagonal at the trot.
 3. Breaking gait.
 4. Excessive speed at any gait.
 5. Excessive slowness in any gait, loss of forward momentum.
 6. Failure to take the appropriate gait when called for.
 7. Head carried too high.
 8. Head carried too low.
 9. Overflexing or straining neck in head carriage so the nose is carried behind the vertical .
 10. Excessive nosing out.
 11. Failure to maintain light contact with the horse's mouth.
 12. Stumbling.
 13. Horse appears sullen, dull, lethargic, emaciated, drawn or overly tired (May also be cause for disqualification per Rule 30).
 14. Refusal to back shall result in a penalty of disqualification at the judge's discretion.
- H. Faults that shall be cause for disqualification, except in novice non-pro or youth, in which faults will be scored according to severity:
 1. Overflexing or straining neck in head carriage so the nose is carried behind the vertical consistently for more than five strides.
- I. TWO-YEAR-OLD SNAFFLE BIT HUNTER UNDER SADDLE
 1. Open to 2-year-old colts, fillies and geldings.
 2. To maintain eligibility the two-year-old year for two-year-old events, entry into other performance events is prohibited with the following exceptions: Two-year-olds may cross enter two-year-old western pleasure, pleasure

driving, 1st year green pleasure classes, snaffle bit/bosal futurities, men's heritage and ladies' heritage. A two-year-old may cross-enter junior western pleasure and/or junior hunter under saddle after May 20 only if there are no other entries in their respective two-year-old class and only if the two-year-old class precedes the junior class(es) on the class list.

- a. In order to maintain two-year-old eligibility, horses may only be shown in equipment acceptable for use in two-year-old classes regardless of which class in which they are exhibited.
- 3. Once a horse is shown in anything other than an acceptable snaffle bit or hackamore/bosal, it is ineligible to compete in Snaffle Bit Hunter Under Saddle. Once a horse has been shown in a mechanical hackamore, it is ineligible to compete in snaffle bit classes.
- 4. A 2-year-old cannot compete in any ApHC-approved performance event prior to May 20th of the current year. National points will not be accumulated for year-end high-point medallions. Points will be accrued for horse's record only.
- 5. See ENGLISH PERFORMANCE EQUIPMENT and ATTIRE, rule 770.A.3 for bit specifications.
- 6. Show management shall provide a minimum of five minutes, not to exceed ten minutes for warm-up period in show ring.
- 7. During the class, horses must be ridden with the same equipment used during the warm-up period.

J. THREE-YEAR-OLD SNAFFLE BIT HUNTER UNDER SADDLE

- 1. Open to 3-year-old stallions, mares, and geldings who have been shown in an acceptable snaffle bit or hackamore/bosal only. Horses shown in any other bit are ineligible.
- 2. All three-year-old horses may be allowed to enter any open, youth or non-pro class ridden two-handed in an acceptable snaffle bit or hackamore/bosal.
- 3. Once a horse is shown in anything other than an acceptable snaffle bit or hackamore/bosal, the horse is ineligible to compete in snaffle bit classes. Once a horse has been shown in a mechanical hackamore, it is ineligible to compete in snaffle bit classes.
- 4. See English Performance Equipment and Attire, rule 770.A.3 for bit specifications.
- 5. Show management shall provide a minimum of five minutes, not to exceed ten minutes for warm-up period in show ring.

K. JUNIOR HUNTER UNDER SADDLE

- 1. Open to all horses five years old and under.
 - a. Two-year-old snaffle bit horses are eligible to be shown in junior hunter under saddle and/or junior western pleasure after May 20 only if there are no other entries in their respective two-year-old class and if the two-year-old class precedes the junior class(es) on the class list.
 - b. Three-year-old snaffle bit horses are eligible.

L. SENIOR HUNTER UNDER SADDLE

- 1. Open to all horses six years old and older.

M. WALK-TROT HUNTER UNDER SADDLE

- 1. Except as noted below, general hunter under saddle rules apply (except that the exhibitors will not be asked to lope but may be asked to extend the trot).
- 2. If the horse breaks into a lope for more than three consecutive strides, it shall be disqualified.
- 3. See YOUTH WALK-TROT DIVISION, rule 807 for rules regarding youth eligibility for youth walk-trot classes.
- 4. See NON-PRO WALK-TROT DIVISION, rule 901.E for rules regarding non-pro eligibility for non-pro walk-trot classes.

773. JUMPING

- A. An Appaloosa open, youth or non-pro jumping is a horse not restricted by previous winnings in any division. Cross entry with Hunter classes shall be allowed.
- B. Exhibitor may ride one or more horses in open and non-pro jumping classes. Youth may ride a maximum of two horses in youth classes.

C. ARENA ARRANGEMENT:

1. There will be a minimum of six obstacles; horses are to make a minimum of eight jumps.
 2. A spread fence consisting of two or more elements will be mandatory.
 3. Optional obstacles may include but are not limited to (it is recommended that first obstacles should be no more than minimum height):
 - a. Post and Rail (at least two).
 - b. Coop.
 - c. Simulated stone or brick wall.
 - d. Triple Bar.
 - e. Brush Jump
 4. The judge has the right and duty to alter the course in any manner to remove any obstacle he deems unsafe. All courses and obstacles are to be constructed with safety in mind so as to eliminate any accidents.
 - a. Prohibited equipment or obstacles include PVC, metal poles and metal boxes.
 5. It is recommended that first obstacles should be no more than minimum height.
 6. Exhibitor must wait for audible signal before proceeding across starting line. The same audible signal is used to stop exhibitor on course, i.e., elimination, fence reset, off course. Both a starting line (at least 12 feet (3.66 m) in front of the first obstacle), and a finish line (at least 24 feet (7.31 m) beyond the last obstacle) must be indicated by markers (at least 12 feet (3.66 m) apart) at each end of the lines. Horse must start and finish by passing between markers.
 7. Obstacles (except within combinations) should be located a minimum distance of 48 feet (14.63 m) apart, size of arena permitting.
 8. Height of obstacles must be a minimum of three feet six inches (106.68 cm) for open classes.
 9. In youth and non-pro classes the height of fences shall be a minimum of three feet three inches (99.06 cm). The maximum first round height for youth and non-pro classes shall be three feet six inches (106.68 cm).
 10. Spreads must be a minimum of three feet (91 cm) except in combinations with a maximum spread of four feet (1.22 m).
- D. Jump-offs: In the case of clean round ties for first place or in the case of ties for point-earning placings, a jump-off shall be held.
1. Jump-offs must be held immediately after the original round of the competition.
 2. Jump-offs will be held over the original course. In a jump-off, the sequence of obstacles may be in any order (1, 3, 6, 7, 9) as long as the original direction of travel is maintained.
 3. The same jump may not be used twice in a jump-off.
 4. The height and spread of at least fifty percent of the obstacles shall be increased not less than three (7.62 cm) and not more than six inches (15.24 cm) in height and to a maximum spread of five feet (1.52 m) for open classes and four feet (1.22 m) for youth and non-pro classes. In case of ties involving faults, rails shall not be raised.
 5. Courses may be shortened for the jump-off. However, the course may not be shortened to less than fifty percent of the original obstacles and must include at least one vertical jump and one spread jump.
 6. In a jump-off, the distance between the elements of a combination may never be altered.
 7. Jump-offs must be timed. The horse with the least number of faults shall be the winner. The winner will be decided on time only if faults are equal.
 8. Time shall be taken from the instant the horse's chest reaches the starting line until it reaches the finish line.
 9. Time shall be stopped while a knocked-down jump is being placed - this is, from the moment the exhibitor gets his mount in a position to retake the jump until the proper authority signals with an audible signal that the jump has been replaced. It shall be the exhibitor's responsibility to be ready to continue the course when the signal is given.

10. In cases of timer failure, a re-run will be permitted.
 11. Jump-off order will be the same as the original order of go.
 12. A competitor who is eliminated in a jump-off will be placed last of the competitors who have completed the jump-off. A competitor who withdraws from a jump-off must always be placed after a competitor eliminated or who retires for a valid reason while on the course.
 13. The first round may be timed in order to break ties (other than those outlined in 773.D). However, this procedure must be stipulated in the premium book conditions for the class.
- E. Both the original course and shortened course must be posted at least one hour before scheduled time of class.
- F. A schooling area must be provided with at least one practice jump.
- G. SCORING.

Jumpers are scored on a mathematical basis and penalty faults, which include knockdowns, disobediences, and falls.

1. Knockdown; An obstacle is considered knocked down, and four faults assessed, when a horse or exhibitor, by contact:
 - a. Lowers any part thereof which establishes the height of any element of a spread obstacle even when the falling part is arrested in its fall by any portion of the obstacle; or
 - b. Moves any part thereof which establishes the height of the obstacle as aforesaid so that it rests on a different support from the one on which it was originally placed.
 - c. If an obstacle falls after the horse leaves the run, it shall not be considered a knockdown.
2. Disobediences:
 - a. Refusal. When a horse stops in front of an obstacle (whether or not the obstacle is knocked down or altered), it is a refusal unless the horse then immediately jumps the obstacles without backing even one step; but if horse takes even one step backwards, it is a refusal.
 - b. If horse is moved toward obstacle after a refusal without attempting to jump, it is considered another refusal.
 - c. In the case of a refusal on an in-and-out jump, the horse must return to the start of the in-and-out sequence and re-jump previous elements as well as following elements.
 - d. Run-out. A run-out occurs when a horse evades or passes the obstacle to be jumped; jumps an obstacle outside its limiting markers; or when horse or exhibitor knocks down a flag, standard, wing or other object limiting the obstacle (without obstacles being jumped).
 - e. Loss of forward movement. Failure to maintain walk, trot, canter, or gallop after crossing starting line (except when it is a refusal, a run-out, or when due to uncontrollable circumstances such as when an obstacle is being reset) is a disobedience.
 - f. Unnecessary circling on course. Any form of circle or circles, whereby the horse crosses its original track between two consecutive obstacles anywhere on course, except to retake obstacles after refusal or run-out, is a disobedience.
 - g. First disobedience (anywhere on the course), 3 faults.
 - h. Second disobedience (anywhere on the course), 6 additional faults.
3. Elimination:
 - a. Failure of the entry to cross starting line within one minute after an audible signal (bell, horn, whistle, gong, buzzer) to proceed is given.
 - b. Third disobedience (anywhere on the course).
 - c. Fall of horse and/or exhibitor.
 - d. Failure to complete course, off course.
 - e. Deliberately addressing an obstacle.
4. In case of broken equipment, the exhibitor may either continue without penalty or stop and correct difficulty, in which case he will be penalized 3 faults. In case of loss of shoe, exhibitor may either continue without penalty or be eliminated.

5. GENERAL:

- a. When a horse makes two faults at one obstacle, only the major fault will be counted, except refusals, which will count in addition.
- b. When an obstacle is composed of several elements in the same vertical plane, a fault at the top element is the only one penalized.
- c. When an obstacle requires two or more fences (in and out), faults committed at each fence are considered separately. In case of a refusal or run-out at one element, entry must re-jump the previous as well as following elements.
- d. An eliminated exhibitor may make one attempt to jump an additional single obstacle but may not continue thereafter.

774. PRELIMINARY JUMPING

- A. Open to horses of any age that have not earned 10 or more total points in open, preliminary, non-pro, and youth jumping.
- B. A horse's preliminary year begins when it competes in a jumping class offering National points. The preliminary horse may cross enter open, youth or non-pro jumping.
- C. When the preliminary horse has earned a total of 10 or more points in open, preliminary, non-pro, and youth jumping, the horse is no longer eligible to compete in Preliminary Jumping after January 1st of the year following accumulation of 10 or more points.
- D. The height of fences is 3'0" to 3'9" (91.44 to 114.3 cm).
- E. For all rules except fence height and eligibility, see JUMPING.

775. WORKING HUNTER

- A. A hunter course shall be any course which management deems a fair test of a hunter, but judges are responsible for correctness of each course after it has been set and shall call the show committee's attention to any errors that would tend to result in unfair or inappropriate courses.
- B. COURSES OR ARENA ARRANGEMENT:
 1. Minimum of six obstacles; horses are to make a minimum of eight jumps, and a minimum of one change of direction is required.
 2. Types of obstacles which may be used:
 - a. Fences shall simulate obstacles found in the hunting field - such as post and rail, stone wall, chicken coop, aiken, hedge, etc.
 1. Jumps such as triple bar, square oxers and hog backs are prohibited.
 2. Jumps or obstacles that include PVC, metal poles and/or metal boxes are prohibited.
 - b. The top element of all fences must be securely placed so that a slight rub will not cause a knockdown;
 - c. Obstacles should be located 48, 60 or 72 feet (14.63, 18.29 or 21.95 m) apart if room permits (exception: combinations);
 - d. Minimum fence height for Working Hunter is three feet (91.44 cm), except during inclement weather in which show management and/or judge may dictate lower heights. Maximum height is three feet three inches (99.06 cm) with a maximum spread of three feet (91.44 cm).
 - e. Minimum height for Youth Working Hunter, Non-Pro Working Hunter and Equitation Over Fences is two feet six inches (76.20 cm). Maximum is two feet nine inches (83.82 cm) with a maximum spread of three feet (91.44 cm).
 - f. The use of wings on obstacles in hunter classes is recommended.
 - g. Ground lines to be established.
 - C. Scoring:
 1. To be judged on manners, way of going and style as jumping. Horses shall be credited with even hunting pace that covers the course with free-flowing strides. Preference will be given to horses with correct jumping style that meet fences

squarely, jumping at the center of fence. Judges shall penalize unsafe jumping and bad form over fence, whether touched or untouched, including twisting. Incorrect leads around the ends of the course or cross cantering shall be penalized, as well as excessive use of crop. In and outs (one or two strides) shall be taken in the correct number of strides or be penalized. Any error that endangers the horse and/or its rider, particularly refusals or knockdowns, shall be heavily penalized.

2. Scoring shall be on the basis of 0-100, with an approximate breakdown as follows:
 - a. 90-100: an excellent performer and good mover that jumps the entire course with cadence, balance and style.
 - b. 80-89: a good performer that jumps all fences reasonably well; an excellent performer that commits one or two minor faults.
 - c. 70-79: the average, fair mover that makes no serious faults, but lacks the style, cadence and good balance of the scoper horses; the good performer that makes a few minor faults.
 - d. 60-69: poor mover that makes minor mistakes; fair or average movers that make one or more poor fences but no major faults or disobediences.
 - e. 50-59: a horse that commits one major fault, such as a hind knockdown, refusal or dropping a leg.
 - f. 30-49: a horse that commits two or more major faults, including front knockdowns and refusals or jumps in a manner that otherwise endangers horse and /or rider.
 - g. 10-29: a horse that avoids elimination but jumps in such an unsafe and dangerous manner as to preclude a higher score.
- D. Soundness: All horses must be serviceably sound. Any horse showing lameness, broken wind, or impairment of vision shall be refused an award. Upon completion of course, horse will be trotted in a circle for soundness by judge's inspection.
- E. Faults:
 1. General
 - a. Judges shall penalize unsafe jumping and bad form over fences, whether touched or untouched.
 - b. Hind knock-downs, not the fault of bad jumping shall not necessarily eliminate a horse from an award, but shall be scored against it in a comparative manner.
 - c. When a horse makes two faults at one obstacle, only the major fault will be counted, except refusals, which will count in addition.
 - d. Circling once upon entering the ring is permitted.
 - e. Horses shall not be requested to re-jump the course.
 - f. Manners shall be emphasized in youth and non-pro classes.
 - g. When an obstacle is composed of several elements, any disturbance of these elements will be penalized; however, only a reduction in height of the top element shall be considered a knockdown.
 - h. In cases of broken equipment, the rider may either continue without penalty, or stop and correct the difficulty and be penalized the same as any loss of forward impulsion.
 - i. When an obstacle requires two or more fences (in and out), faults committed at each obstacle are considered separately. In case of a refusal or run-out at one element, entry may rejump the previous elements.
 2. Minor Faults - Minor faults are scored according to judges' opinion, and depending on severity, may or may not fall under the major fault category.
 - a. Light touches or rubs against a jump.
 - b. Missing a lead change.
 - c. Switching leads.
 - d. Kicking out.
 - e. Adding a stride between jumps.
 - f. Leaving a stride out between jumps.

- g. Spooking or shying.
 - h. Pinning ears or wringing tail.
 - i. Jumping out of turn.
 - j. Not straight or in center of fence.
 - k. Poor presentation of horse or exhibitor.
3. Major faults
- a. Knock down of rail.
 - b. Refusals.
 - c. Trotting while on course when it is not specified.
 - d. Bucking.
 - e. Stopping for loss of shoe or broken equipment.
 - f. Circling while on course.
 - g. Pulling up.
 - h. Dangerous jumping.
4. Elimination
- a. 3 refusals.
 - b. Off course.
 - c. Jumping a fence before it is reset.
 - d. Bolting from the ring.
 - e. Fall of horse or exhibitor. A horse is considered to have fallen when shoulder and haunch of the same side touch the ground or the obstacle and the ground.
 - f. Deliberately addressing an obstacle.

776. GREEN HUNTER

- A. This class is open to:
1. Horses of any age in their first year of showing over a course of fences in ApHC-approved or -sponsored events or in any recognized show. A "recognized" show shall be deemed to be any show approved by the ApHC or by the United States Equestrian Federation (USEF); or
 2. Horses that have shown during the previous year(s) but have accumulated less than 25 total points as of January 1 of the current year in Green Hunter, Working Hunter (youth and non-pro) and, equitation over fences (youth and non-pro) at ApHC-approved or sponsored shows.
- B. If the horse has shown in any ApHC-approved or -sponsored show or at any recognized show prior to January 1 of the current year in Working Hunter (open), Jumping (youth, non-pro or open) or Preliminary Jumping, it is ineligible to compete in Green Hunter.
- C. If a horse has been shown in any over fence class where the fence height exceeded 2'9" (83.82 cm) prior to January 1 of the current year in any approved, sponsored, or recognized show, that horse is expressly denied the right to compete in Green Hunter.
- D. Once a horse has won a National or World Championship in Green Hunter, it is no longer eligible to compete in Green Hunter at the end of that calendar year.
- E. During the year of Green Hunter competition, the horse may cross enter into Working Hunter (youth, non-pro or open), equitation over fences (youth or non-pro), Jumping (youth, non-pro or open) or Preliminary Jumping. However, once the horse has shown in Working Hunter (open), Jumping (youth, non-pro or open) or Preliminary Jumping, that horse is ineligible to compete in Green Hunter as of December 31 of that year.
- F. The minimum fence height for Green Hunter is 2'9" (83.82 cm). The maximum fence height is 3'0" (91.44 cm).
- G. For all other rules except fence height and eligibility, see WORKING HUNTER.
- H. Green hunter may not be combined with pre-green hunter.

777. PRE-GREEN HUNTER

- A. Open to horses of any age in their first year of showing over a course of fences in ApHC-approved or -sponsored events or in any recognized show. A "recognized" show shall be deemed to be any show approved by the ApHC or by the United States Equestrian Federation (USEF).
- B. If the horse has shown in any ApHC-approved or -sponsored show or at any recognized show in any over fence class including but not limited to Jumping (youth, non-pro or open), Preliminary Jumping, Working Hunter (youth, non-pro or open), Green Hunter, Pre-Green Hunter, (in any previous year) or equitation over fences (youth or non-pro), it is ineligible to compete in Pre-Green Hunter.
- C. However, during the year of pre-green competition, the horse may cross enter into Working Hunter (youth or non-pro), equitation over fences (youth or non-pro) or Hunter Hack (youth, non-pro or open) as long as the fence height doesn't exceed 2'9" (83.82 cm).
- D. Horses may not cross enter into Green Hunter, Working Hunter (open), Jumping (youth, non-pro or open) or Preliminary Jumping during the year of pre-green competition. Once the horse has shown in any of these classes, it is ineligible to continue competing in Pre-Green Hunter. Once a horse shows in any class at a fence height that exceeds 2'9" (83.82 cm), the horse is ineligible to continue competing in Pre-Green Hunter.
- E. Pre-Green Hunter begins when the horse competes in any over fence class at an ApHC-approved or sponsored show, or at any show approved by the USEF and ends on December 31 of that year.
- F. The minimum fence height for Pre-Green Hunter is 2'6" (76.20 cm). The maximum fence height is 2'9" (83.82 cm).
- G. For all other rules except fence height and eligibility, see WORKING HUNTER.
- H. Pre-green hunter may not be combined with green hunter.

778. HUNTER HACK

- A. Open to horses of any age.
- B. The hunter hack horse should move in the same style as a working hunter. The class will be judged on style over fences, event hunting pace, flat work, manners, and way of going.
- C. Horses are first required to jump two fences.
1. The first fence may be 2'0", 2'3" or 2'6" (60.96 cm, 68.58 cm, 76.20 cm), but in no event more than 3 inches (7.62 cm) lower than the second fence. The second fence may be 2'3", 2'6" or 2'9" (68.58 cm, 76.20 cm or 83.82 cm). The fence height at any ApHC-sponsored event must be 2'6" (76.20 cm) for the first fence and 2'9" (83.82 cm) for the second fence.
 2. Fences may be in a line and should be set at distance of 48', 60' or 72' (14.63 m, 18.28 m, 21.95 m) or in increments of 12' (3.66 m). A ground line is required for each jump. Fences are not required to be placed in a line.
 3. All obstacles are to be constructed with safety in mind so as to eliminate any accidents. Obstacles that include PVC, metal poles and/or metal boxes are prohibited.
 4. The lead change between fences shall be optional.
 5. At the discretion of the judge, exhibitors may be asked to hand gallop, pull up, back and stand quietly on a loose rein following the last fence.
- D. Horses being considered for an award must then be shown at a walk, trot and canter both ways of the ring with light contact.
- E. When necessary to split large classes by running more than one go-round, finalists must both be re-jumped and re-worked on the flat.
- F. Placing for the class shall be determined by allowing a minimum of 70% for individual fence work and a maximum of 30% for work on the flat.
- G. Faults over fences will be scored as in Working Hunter. Horses eliminated in the over-fence portion of the class per rule 775.E.4 shall be disqualified.

H. Faults to be scored accordingly, but not necessarily cause disqualification during rail work include:

1. Being on wrong lead and/or being on wrong diagonal at the trot
2. Excessive speed at any gait
3. Excessive slowness at any gait
4. Breaking gait
5. Failure to take gait when called
6. Head carried too low or too high
7. Nosing out or flexing behind the vertical
8. Opening mouth excessively
9. Stumbling

779. SADDLE SEAT PLEASURE

A. PERSONAL APPOINTMENTS: Saddle suits or Kentucky jodhpurs and saddle-suit-type jackets are required. Ties are required. Chokers are prohibited. Gloves are preferred.

1. Informal (prior to 6 p.m.): Conservative colors are preferred. Solid colors include a black, blue, grey, green, beige or brown jacket with matching jodhpurs. Herringbone, pinstripes and other combinations of colors that appear to be solid are also acceptable. Derby or soft hat is required. All appointment colors shall be acceptable. However, preference is given to traditional conservative colors.
2. Formal (after 6 p.m.): Even more conservative attire is preferred for evening classes. Conservative solid colors, including dark grey, dark brown, dark blue or black tuxedo-type saddle suit with collars and lapels of the same color, top hat, Kentucky jodhpurs to match and gloves, or dark colored riding habit (saddle suit) and accessories are preferred. It is preferred that formal attire be worn after 6 p.m. If formal riding habits are worn before 6 p.m., the exhibitor shall be disqualified.
3. As per Rule 770.D.2, protective headgear passing or surpassing current applicable ASTM standards with harness secured and properly fitted is acceptable.

B. TACK APPOINTMENTS (required): Bridle: Senior entries shall be shown in full bridles. Either Weymouth or Pelham bits may be used in full bridle (double-reined bridle) with browband and cavesson - colored, silver or plain leather. Junior entries may be shown in a snaffle bit as defined in Rule 770.A.3. Saddle: Show, Cutback or Park type English saddles are to be used. Web, cord, leather or linen girths are permitted. All tack to be neat and clean.

C. OPTIONAL APPOINTMENTS: Spurs of the unroweled English type and crops are optional.

D. PROHIBITED APPOINTMENTS: Any deviation from required bits, bit converter straps, boots of any description, running or standing martingales, tie-downs or draw reins, dropped nosebands are not allowed. Artificial appliances, forward seat saddles with extreme knee rolls, western saddles, or side saddles are prohibited.

E. GAITS. Horses to be shown at a walk, trot and canter both ways of the ring. To stand quietly and back readily. It is the judge's option to require an exhibitor to back his horse or to extend any gait. Horses must be brought to a flat-footed walk before changing gaits. The trot should be brisk, smart, cadenced and balanced without loss of form. Smoothness is more essential than extreme speed. An extended trot may be called for at the judge's option. The canter should be smooth, collected and straight on both leads with the ability to push on if so required. Light contact with horse's mouth must be maintained. Horses to perform with natural animated, cadenced motion under moderate collection; extremely high artificial action will be severely penalized. Horses not to be stretched (parked). Horses should be obedient, alert, responsive and move freely; they need not be eliminated for slight errors. Horses to be judged on performance with emphasis on presence (style), quality (finesse), suitability of purpose and brilliance.

Rules 780-789 are not assigned.

790. SHOWMANSHIP AND HORSEMANSHIP/EQUITATION CLASSES

- A. In all showmanship classes and in all horsemanship/equitation classes, (except leadline and walk-trot), the judge must first work each exhibitor individually.
- B. Use of markers helps to standardize patterns and guide exhibitors, but they also increase the degree of difficulty somewhat, so their placement should be carefully planned and indicated in the posted pattern, and their placement in the arena well supervised.
- C. The pattern must be posted at least one hour prior to the class commencing.
- D. Failure to complete the pattern will not be a disqualification, but shall be scored accordingly. If a show prepares patterns, the judge(s) must approve use of such patterns.
- E. In horsemanship/equitation classes exhibitors must work individually using an appropriate test in which they are asked to demonstrate all three gaits. After each exhibitor has been worked individually, the judge may:
 1. Recall all the exhibitors or just the finalists for rail work.
 - a. If the judge chooses to recall exhibitors for rail work, the exhibitors must be worked at least one way of the ring demonstrating all three gaits, or
 2. Place the class.
- F. A junior horse ridden two-handed in an acceptable snaffle bit or hackamore bosal may be shown in bareback horsemanship, western horsemanship, hunt seat equitation, leadline, or walk-trot.
- G. In horsemanship/equitation classes, for reason of safety, exhibitors will not be required to mount and dismount.
- H. In hunt seat equitation classes, the trot and canter patterns must cover a minimum of 60 feet/18.3 meters. In western horsemanship classes, the patterns must be set so that the lope portions of the patterns cover a minimum of 60 feet/18.3 meters.

791. SHOWMANSHIP AT HALTER: WESTERN

- A. The Showmanship at Halter class may be held as one (18 & under) or two (13 & under, 14-18) or three (12 & under, 13-15, 16-18) age groups. Showmanship Classes may be combined or 18 & under classes may be split at the direction of the judge or show management with the unanimous consent of all exhibitors involved in the class (or classes) in question. Novice showmanship may be held as 18 & under or 13 & under and 14-18.
- B. The handler of the animal is judged on his or her ability to present the horse. The horse is merely a prop used to show the ability of the handler.
- C. The conduct of the classes shall be at the judge's discretion and direction. The judge may require any maneuver he/she feels necessary to determine the ability of the exhibitor.
- D. Personal appearance of exhibitor: Neat, clean, well groomed, attentive and courteous.
- E. The horse should be clean, well-groomed and in excellent physical condition. The exhibitor must walk, trot, stop and back the horse as directed by the judge. Keep the horse posed and know where the judge is at all times and be aware of the judge's expectations.
- F. Exhibitor must lead from the left side of your horse with your right hand on the lead strap about eight to twelve inches (20.32 cm to 30.48 cm) from the halter. Smaller exhibitors may need to use a longer hold on the lead strap. Hold the excess lead strap in your left hand, either in a figure-8 or in a round coil. The method of holding the excess lead shank is optional, so long as it is being handled safely by the exhibitor.
- G. The showman must always have an unobstructed view of the judge, must always be presenting the horse and must always know what his/her horse is doing.
- H. If the judge is standing at the rear quarters of the horse, the showman must be on the same side of the horse as the judge.
- I. If the judge is standing at the front quarters of the horse, the showman is on the opposite side of the horse as the judge.

- J. In either case the showman must keep the judge within his/her field of vision at all times, and should never stand directly in front of the horse.
- K. The exhibitors will only be required to show their horses (by the quarter method) for the distance of one horse on either side of where the judge is judging.
- L. Each exhibitor will be required to travel his horse individually, leading the horse from the left, regardless of where the judge stands in the ring for traveling the horses to and away from him or her, the following principles shall apply:
 1. The exhibitor shall always lead the horse from the horse's left (near) side.
 2. All turns shall be to the right with the exhibitor walking to the right around the horse.
- M. When lining up, stand your horse squarely on all four feet.
- N. Exhibitors must keep proper position in line and allow reasonable space (at least five feet (1.52 m)) between horses. Exhibitors must be prepared to follow any request made by the judge and ring steward.
- O. The following will be considered faults against the exhibitor:
 1. Failure to recognize and correct faults of the horse's position.
 2. Visiting or conversing with other exhibitors in the arena during judging of Showmanship at Halter.
 3. Kicking or placing the horse's leg into position (actual contact with horse's leg).
 4. Failure of the horse to lead properly.
 5. Failure to back horse when necessary.
 6. Loud voice commands to the horse.
 7. Over showing through unnecessary actions.
 8. Blocking the judge's view of the horse.
 9. Turning horse the wrong direction.
 10. Causing the judge to move to avoid being bumped or stepped on by the horse.
 11. Improperly fitting equipment.
- P. Chaps and spurs should not be worn.
- Q. Equipment: Halter - leather, rope or nylon, clean and adjusted to fit. The lead strap or lead rope should be six or seven feet (1.83 m or 2.13 m) long. Hackamores and bridles shall not be used when showing at halter. No whips, bats, or quirts will be permitted in Showmanship at Halter. A judge will not penalize an exhibitor for the use of a chain lead over the horse's nose or under the horse's jaw as a restraint. The use of this equipment will not be cause for disqualification.

R. WALK-TROT SHOWMANSHIP

1. General showmanship rules apply.
2. The judge must first work each exhibitor individually.
3. See YOUTH WALK-TROT DIVISION, rule 807 for rules regarding youth eligibility for youth walk-trot classes.

792. SHOWMANSHIP AT HALTER: ENGLISH

- A. The Showmanship at Halter class may be held as one (18 & under) or two (13 & under, 14-18) or three (12 & under, 13-15, 16-18) age groups. Showmanship Classes may be combined or 18 & under classes may be split at the direction of the judge or show management with the unanimous consent of all exhibitors involved in the class (or classes) in question.
- B. The handler of the animal is judged on his or her ability to present the horse. The horse is merely a prop used to show the ability of the handler.
- C. The conduct of the classes shall be at the judge's discretion and direction.
- D. Personal appearance of exhibitor: Neat, clean, well-groomed, attentive and courteous.
- E. The horse should be clean, well-groomed and in excellent physical condition. The exhibitor must be able to walk, trot, stop and back the horse as directed by the judge. Keep your horse posed and know where the judge is at all times and what he wants.

- F. The showman must always have an unobstructed view of the judge, must always be presenting the horse and must always know what his/her horse is doing. The horse should be presented from the front with an attempt to keep the judge within plain sight at all times. A variation of one step to either side would be acceptable.
- G. The exhibitors will only be required to show their horses for the distance of one horse on either side of where the judge is judging.
- H. Each exhibitor will be required to travel his/her horse individually, regardless of where the judge stands in the ring for traveling the horses to and away from him or her, the following principles shall apply:
 1. The exhibitor shall always lead the horse from the horse's left side.
 2. All turns shall be to the right with the exhibitor walking to the right around the horse.
- I. When lining up, stand your horse squarely on all four feet.
- J. Exhibitors must keep proper position in line and allow reasonable space (at least five feet (1.52 m)) between horses. Exhibitors must be prepared to follow any request made by the judge and ring steward.
- K. The following will be considered faults against the exhibitor:
 1. Failure to recognize and correct faults of the horse's position.
 2. Visiting or conversing with other exhibitors in the arena during judging of the Showmanship class.
 3. Kicking or placing the horse's leg into position (actual contact with horse's leg).
 4. Failure of the horse to lead properly.
 5. Failure to back horse when necessary.
 6. Loud voice commands to the horse.
 7. Over-showing through unnecessary actions.
 8. Blocking the judge's view of the horse.
 9. Turning horse the wrong direction.
 10. Causing the judge to move to avoid being bumped or stepped on by the horse.
 11. Improperly fitting equipment
- L. Equipment: English headstall equipped with any acceptable single-rein English bit (see ENGLISH PERFORMANCE specifications) and that complies with appropriate equipment rules for the age of the horse shown. The reins will be held together approximately 6–10 inches (15.24cm: 25.4cm) below the horse's chin with the right hand, with the remainder of the reins held in the exhibitor's left hand. No whips, bats or quirts will be permitted in English Showmanship at Halter. Notwithstanding the above, English bridle is mandatory on horses two years old and older and plain leather halter is required on weanling and yearling horses.
- M. Personal attire: The exhibitor shall be attired in hunt seat attire which will consist of a hunt seat jacket (conservative colors), hunt seat britches or jodhpurs, hunt seat boots, hard hat, keeping in mind that personal appearance is important (neat, clean and well groomed). Saddleseat attire is not permitted in this class due to the difference in the "cut" of the clothes which can be distracting. No spurs will be permitted in an English Showmanship class. **Gloves are optional.**

793. LEADLINE EQUITATION/HORSEMANSHIP

- A. The class will enter the ring at a flat-footed walk, as designated. The class will be worked at a walk only both directions of the ring. In the line-up the judge may ask the exhibitors to back up their horses to help him or her judge the extent of the exhibitor's horsemanship.
- B. The exhibitor will be judged on his or her basic position in the saddle: Hand position, seat position, and back position. The horse must be led and controlled by an adult (over 18 years of age). A lead shank at least six feet (1.83 m) long must be attached to the shank of the bit or to a halter that is under or over the bridle so that while the exhibitor is on the rail the horse is controlled by the adult. If the judge asks the exhibitor to back the horse in the line-up, the adult should not aid the exhibitor. The adult should only keep the horse under control. The exhibitor may ride Western or English in this class. Person leading horse is to be dressed in accordance with the exhibitor.

- C. A junior horse ridden two-handed in an acceptable snaffle bit or hackamore/bosal may be exhibited in Leadline.
- D. This class is limited to exhibitors 6 years old and under who do not participate in any approved class at that show except Showmanship and Halter.
- E. For Leadline classes only, the youth exhibitor or their family need not be the owner of the horse. However, the owner of the horse must be an ApHC member.
- F. In leadline chaps are optional as a western requirement. See WESTERN PERFORMANCE ATTIRE.

794. WALK-TROT EQUITATION/HORSEMANSHIP

- A. The conditions of this class are the same as outlined under Western Horsemanship and Hunt Seat English Equitation (with the exception that contestants will not be asked to lope but may be asked to extend the jog or trot).
- B. Patterns may be used in walk-trot hunt seat equitation and walk-trot western horsemanship.
 - 1. If patterns are used in walk-trot equitation classes, rail work is optional as per Rule 790.E.
 - 2. If patterns are NOT used, then rail work is required and the exhibitors must be worked both directions of the ring.
- C. The walk-trot class may be offered as a Western or English class, however, the two may not be combined.
- D. The class will enter the arena as designated. In the line-up the judge may ask exhibitors to back up their horses to help him judge the extent of the exhibitor's horsemanship.
- E. The exhibitor will be judged on his or her basic position in the saddle: hand position, leg position and back position. The exhibitor will also be judged on his/her ability to govern, control and properly exhibit the mount he/she is riding.
- F. If the horse breaks into a lope for more than three consecutive strides, it shall be disqualified.
- G. In equitation classes, for reasons of safety, exhibitors will not be required to mount and dismount.
- H. A junior horse ridden two-handed in an acceptable snaffle bit or hackamore/bosal may be exhibited in walk-trot classes.
- I. See YOUTH WALK-TROT DIVISION, rule 807 for rules regarding youth eligibility for youth walk-trot classes.
- J. See NON-PRO WALK-TROT DIVISION, rule 901.E for rules regarding non-pro eligibility for non-pro walk-trot classes.

795. BAREBACK HORSEMANSHIP

- A. The exhibitor is judged in this class on his or her ability to ride and control a horse properly without the use of a stock saddle. The exhibitor shall be judged on his or her basic position: position of hand or hands, leg position, seat position and back position. To further explain, a exhibitor should sit in a balanced relaxed manner, up close to the horse's withers, keeping the back straight and shoulders even. The exhibitor should keep his or her arms in close to the body. The rein hand or hands should be held loosely and should be positioned directly above and in front of where the saddle horn would be if the exhibitor were using a saddle. The position of the exhibitor's free hand is optional but should indicate a relaxed, not sloppy, balanced attitude of the body and should be kept free of the horse except that exhibitor may hold a romal to keep it from swinging and to adjust the position of the reins provided it is held at least 16" (40.64 cm) from the reining hand. The legs maintain contact with the horse, giving the necessary leg grip. The foot is turned out slightly and the heels should be level or slightly lowered close to the horse just behind the horse's elbows. The exhibitor should be in balance with his or her horse at all times and should be able to sit the trot bareback. No posting at the trot will be permitted. An imaginary straight line drawn from the exhibitor's shoulders or hip should drop at the back

of the heel and a straight line from the knee should drop in front of the toe. The exhibitor in this class must be able to display, through his or her riding ability in the ring, his or her knowledge of how to handle a horse properly. The exhibitor is penalized if he or she uses two hands on the reins (except when riding a junior horse in an acceptable snaffle bit or hackamore/bosal), changes hands on the reins, or touches any part of the horse with his or her free hand. While the horse is in motion the exhibitor's hands shall be clear of the horse.

- B. Individual work must be comprised of any of the following:
 1. Back.
 2. Walk, jog, trot, lope, in a straight line, curve or circle, or any combination of these gaits and patterns such as figure eights, etc.
 3. Stop.
 4. Turn on the haunches or forehand.
 5. Side pass.
 6. Simple lead change.
 7. Flying lead change.
 8. Counter canter.
 9. Extended gaits.
 10. In equitation classes, for reasons of safety, exhibitors will not be required to mount and dismount.

796. WESTERN HORSEMANSHIP

- A. Exhibitors to be judged on hands, seat and legs and on their ability to ride and control a horse properly. Results, as shown by the performance of the horse are not to be considered more important than the methods used by the exhibitor in obtaining them. Good hands are paramount. Exhibitors to be always on correct lead.
- B. Arms are to be in a straight line with the body, with the one holding the reins bent at the elbow. A junior horse ridden two-handed in an acceptable snaffle bit or hackamore/bosal may be exhibited. When riding a senior horse, only one hand is to be used for reining and hands shall not be changed. Reins to be held above the horn and as near to it as possible. The position of the exhibitor's free hand is optional, but it should be kept free of the horse and equipment and held in a relaxed manner with the exhibitor's body straight at all times. Exhibitor may hold romal to keep it from swinging and to adjust the position of the reins, provided it is held at least 16" (40.64 cm) from the reining hand. Bracing against horn will be penalized. The exhibitor should sit in the saddle in a balanced, relaxed manner, with his/her back straight and shoulders even, and arms close to the body. The stirrups should be just short enough to allow the heels to be lower than the toes. Knees should be slightly bent and weight be directly over the balls of the feet. Body always should appear comfortable, relaxed and flexible. Feet should be placed in the stirrups with weight on the ball of the foot and turned out just slightly. Consideration, however, should be given to the width of the stirrups, which vary on western saddles. The legs must maintain contact with the horse, to give aids to the horse. Position in motion: Exhibitor should sit to the jog-trot and extended trot and not post. At the lope, he/she should be close to the saddle. All movements of the horse should be governed by the use of imperceptible aids, and the shifting of exhibitor's weight is not desirable.
- C. An exhibitor is penalized if he or she loses a stirrup, uses two hands on the reins except when riding a junior horse in an acceptable snaffle bit or hackamore/bosal, changes hands on the reins, or touches any part of the saddle with his or her free hand.
- D. Individual work must be comprised of any of the following:
 1. Back.
 2. Walk, jog, trot, lope, in a straight line, curve or circle, or any combination of these gaits and patterns such as figure eights, etc.
 3. Stop.
 4. Turn on the haunches or forehand.
 5. Side pass.

6. Simple lead change.
7. Flying lead change.
8. Counter canter.
9. Ride without stirrups.
10. Extended gaits.

11. In equitation classes, for reasons of safety, exhibitors will not be required to mount and dismount.

797. HUNT SEAT EQUITATION

- A. Exhibitors to be judged on hands, seat and legs and on their ability to ride and control a horse properly.
- B. Hands should be above and in front of horse's withers, knuckles thirty degrees inside the vertical, hands slightly apart and making a straight line from horse's mouth to exhibitor's elbow. Method of holding reins is optional and bight of reins may fall on either side; however, all reins must be picked up at the same time. The eyes should be up and shoulders back. Toes should be at an angle best suited to exhibitor's conformation; ankles flexed in, heels down, calf of leg in contact with horse and slightly behind girth. Stirrup must be on the ball of the foot. The following is for flat class only: Position in motion. At the walk, sitting trot and canter, body should be a couple of degrees in front of the vertical; posting trot, and galloping, inclined forward.

Riding Position:

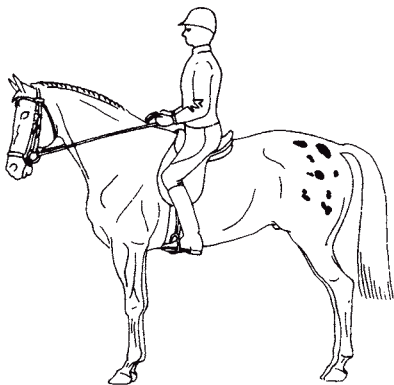

- C. Exhibitors and judges to bear in mind all entries are being judged on ability.
- D. Individual work must be comprised of any of the following:
 1. Back.
 2. Hand gallop.
 3. Figure eight at the trot, demonstrating change of diagonal.
 4. Figure eight at the canter on correct lead, demonstrating either a simple change of lead or flying change of lead.
 5. Ride without irons.
 6. Drop and pick up irons.
 7. Turn on the forehand.
(A turn on the forehand to the right is accomplished by moving haunches to the left. A forehand turn to the left is accomplished by moving haunches to the right.)
 8. Serpentine at either trot or canter.
 9. Canter on counter lead.
 10. Turn on haunches.
 11. Stop.
12. In equitation classes, for reasons of safety, exhibitors will not be required to mount and dismount.

798. SADDLE SEAT EQUITATION

- A. Exhibitors to be judged on hands, seat and legs and on their ability to ride and control a horse properly. Hands should be held in an easy position, neither perpendicular nor horizontal to the saddle, and should show sympathy, adaptability and control.
- B. The height the hands are held above the horse's withers is a matter of how and where the horse carries its head. The method of holding the reins is optional except that both hands shall be used and all reins must be picked up at one time. Bight of rein should be on the off side.
- C. To obtain proper position, exhibitor should place himself comfortably in the saddle and find his or her center of gravity by sitting with a slight bend at the knees, but without use of irons. While in this position adjust leathers to fit. Irons should be placed under ball of foot (not toe nor "home"), with even pressure on entire width of sole and center of iron. Foot position should be natural (neither extremely in nor out). Spurs are optional.
- D. POSITION IN MOTION:
 1. Walk: Slight motion in saddle.
 2. Trot: Slight elevation in saddle posting; hips under body, not mechanical up and down, nor swing forward and backward.
 3. Canter: Close seat, going with horse. Exhibitors and judges should bear in mind that at all times entries are being judged on ability. Judges shall eliminate those contestants who do not conform.
- E. Individual work must be comprised of any of the following
 1. Back.
 2. Serpentine, circle, figure eight at trot, demonstrating change of diagonal.
 3. Serpentine, figure eight or circle at the canter on correct lead, demonstrating simple change of lead.
 4. Simple change of leads.
 5. Ride without stirrups.
 6. Stop.
 7. In equitation classes, for reasons of safety, exhibitors will not be required to mount and dismount.
- F. PERSONAL APPOINTMENTS: Exhibitors and judges should bear in mind that at all times entries are being judged on ability. However, neatness is the first requisite regarding an exhibitor's attire and the following requirements are based on tradition and general present day customs. Judges must eliminate those competitors who do not conform.
 1. Saddle suits or Kentucky jodhpurs and saddle suit type jackets are required. Ties are required. Chokers are prohibited. Gloves are preferred.
 - a. Informal (prior to 6 p.m.): Conservative colors are required. Solid colors include black, blue, grey, dark burgundy, dark green, beige or brown jacket with matching jodhpurs, derby hat and jodhpur boots. Herringbone, pinstripes and other combinations of colors that appear to be solid are also acceptable.
 - b. Formal (after 6 p.m.): Conservative colors are required for saddle seat equitation and even more conservative attire is preferred but not required for evening classes. Solid colors include dark grey, dark brown, dark blue or black tuxedo-type jacket with collars and lapels of the same color, top hat, jodhpurs to match and gloves or dark-colored riding habit, accessories and jodhpur boots. If formal riding habits are worn before 6 p.m., the exhibitor shall be disqualified.
 2. As per rule 770.D.2, protective headgear passing or surpassing current applicable ASTM standards with harness secured and properly fitted is acceptable.

- G. TACK APPOINTMENTS (required): Bridle: Entries shall be shown in full bridles. Either Weymouth or Pelham bits may be used in full bridle (double-reined bridle) with browband and cavesson - colored, silver or plain leather. Saddle: Show, Cutback or Park type English saddles are to be used. Web, cord, leather or linen girths are permitted. All tack to be neat and clean.
- H. OPTIONAL EQUIPMENT: Spurs of the unroweled English type and crops are optional.
- I. PROHIBITED EQUIPMENT: Any deviation from required bits, bit converter straps, boots of any description, running or standing martingales, tie-downs or draw reins, dropped nosebands are not allowed. Artificial appliances, forward seat saddles with extreme knee rolls, western saddles, or side saddles are prohibited.

799. HUNT SEAT EQUITATION OVER FENCES

- A. Classes must be held over a minimum of four obstacles and a maximum of eight obstacles. Horses are to make a minimum of eight jumps, and a minimum of one change of direction is required. General hunt seat equitation rules apply.
- B. The performance begins when the horse enters the ring or is given the signal to proceed after entering the ring. Except for refusals, jumping faults of the horse are not to be considered unless it is a result of the exhibitor's ability.
- C. The following will result in elimination:
1. Fall of horse and/or exhibitor.
 2. Three cumulative refusals.
 3. Off course.
- D. If elimination occurs during a ride-off, the exhibitor is placed last of all those chosen for the ride-off.
- E. The following constitute major faults and can be cause for elimination.
1. Refusal.
 2. Loss of stirrup.
 3. Trotting while on course when not part of a test.
 4. Loss of reins.
- F. Each exhibitor may circle once before approaching the first obstacle. He then proceeds around course, keeping an even pace throughout. If a refusal occurs on a double or triple, exhibitor must re-jump all obstacles in the combination. Any or all exhibitors can be called back to perform at a walk, trot, and canter, or to execute any appropriate tests included in class requirements.
- G. Minimum height for obstacles is two feet six inches (76.2 cm). Maximum height is two feet nine inches (83.82 cm). Maximum spread is three feet (91 cm).

YOUTH PROGRAM

The purpose of the Appaloosa Horse Club youth program is:

- To develop policy and help guide regional club youth programs.
- To carry on a variety of special promotions to give the youth program a national reputation.
- To provide a variety of promotional supplies, services and educational materials that will help each regional club develop its programs.
- To emphasize good horsemanship through proper methods of training both horse and exhibitor.
- To provide recognition for young people who currently own or show Appaloosas.
- To stimulate interest in Appaloosas by encouraging participation in some aspect of the youth program.
- To promote a program with the ideals of citizenship, sportsmanship, showmanship, leadership, and to develop pride in owning an Appaloosa.
- To provide a variety of educational aids through which an understanding of the breed will be disseminated throughout the United States.

800. APPALOOSA YOUTH ASSOCIATION

- A. The Appaloosa Youth Association (AYA), is an organization made up of and governed by youth interested in Appaloosa horses. The AYA is an organization through which youth in the Appaloosa industry may have direct input into the ApHC youth program. The AYA sponsors a variety of activities in an effort to achieve the above-stated ApHC youth program purposes and objectives.
- B. Membership in the Appaloosa Youth Association entitles youth to be eligible to compete for National youth points in youth classes. This membership also allows youth to enter open classes at any ApHC-approved or sponsored show. AYA membership includes all ApHC membership privileges except the right to vote in ApHC Board of Directors elections. These privileges include access to ApHC services, discounts, and benefits. This membership is included in the family fee or can be purchased separately. Youth memberships are non-refundable and non-transferable and all requirements must be in the office before points will be awarded.
- C. Appaloosa Youth Association activities may include but are not limited to the following: A National Youth Show, team tournament, judging contests, territorial and regional youth clinics, publication of a youth horsemanship manual and other publications including outlines, guides, etc. to aid regional clubs and individual members in the establishment and maintenance of youth programs and youth development. Also, the association will provide materials, including outstanding accomplishments of youths with Appaloosas in the show ring and in other endeavors, for publication by the ApHC in *Appaloosa Journal* and/or the ApHC web site and/or by electronic communication to ApHC members.

D. GENERAL RULES

1. Members shall consist of individuals 18 years of age or younger as of January 1 of the current year. (Age to be retained throughout the calendar year). Married or divorced individuals are ineligible for membership in the Appaloosa Youth Association. A one-time youth membership fee is also available. (See Rule 10.B.2)
2. Annual youth membership fees are required to be paid in order to receive national points. The youth's date of birth and parent's or guardian's signature must be on file in the ApHC office before that youth can receive points.
3. Each current Appaloosa Youth Association membership constitutes one vote in the annual AYA election of directors and/or at the annual AYA membership meeting. On the election ballot, each AYA member will vote for one candidate in each territory and zone. The votes for candidates outside the home territory of each AYA member will only be counted in the case that a tie occurs in the election. In case of a tie, votes cast by AYA members who live outside of the territory in which the tie occurred will be counted to break the tie.
4. AYA Board of Directors
 - a. The AYA shall be governed by a board of directors consisting of one youth from each ApHC zone in each territory. In order to serve as an AYA Director, a youth must be a current AYA member residing in the zone and territory for which he/she would represent, and not less than 14 nor more than 17 years of age as of January 1 of the first year of his/her two-year term. The AYA board of directors shall have the power and authority to direct the affairs of the organization with the approval of the ApHC Board of Directors.
 - b. The term of office for each AYA Director shall be two years, from January 5 to January 4, or from announcement of election results to announcement of election results. Nine directors will be elected in odd

- years and nine directors will be elected in even years. In odd years, directors will be elected from zones A & C in territories II, IV & VI and from zone B in territories I, III & V. These directors will begin serving their term in an even year. In even years, directors will be elected from zone B in territories II, IV & VI and from zones A & C in territories I, III & V. These directors will begin serving their term in an odd year.
- c. Following his/her election, should a director get married or move from his/her zone and territory, he/she must resign and the position will be filled by the runner-up from that territory/zone, if still eligible.
5. ELECTION: The Appaloosa Youth Association election will be held according to the following schedule:
- a. September 10 - Closing date for declaration of candidacy. Declaration form must be received in the ApHC office no later than September 10 in order for the candidate's name to be placed on the ballot.
 - b. November 1 - Youth memberships must be received in the ApHC office in order to receive an election ballot.
 - c. November 15 - Voting begins.
 - d. December 13 - Closing date of election.
 - e. January 5 - Results of the final election will be available. If any of the dates fall on a holiday or a weekend, the following work-day will be considered the final date.
6. Advisory Board:
- a. The Advisory Board may consist of: The President of the AYA, the ApHC Youth Coordinator, the ApHC Chief Executive Officer and Treasurer, and other members appointed by the ApHC Board of Directors and/or the Advisory Board and/or the AYA Board of Directors. The number of youth on the board must equal the number of adults.
 - b. The annual meetings of the AYA membership and AYA Board of Directors shall be held at the site of the National Appaloosa Youth Horse Show each year or at such other site and date as designated by the AYA and ApHC Board of Directors. Only current members of the AYA are eligible to attend, speak and vote at the annual meeting, except that the ApHC Youth Coordinator can attend and speak, but not vote. At the discretion of the Board of Directors, non-members may be permitted to attend as observers only, but must be seated separately.
 - c. All correspondence regarding the AYA should be directed to the Youth Department of the Appaloosa Horse Club, 2720 W Pullman Road, Moscow, Idaho 83843.

801. YOUTH RULES

- A. All youth competing in approved youth classes must be youth members. In order to receive national youth points, the youth must also own the horse as evidenced by records of the ApHC and the Certificate of Registration of such horse at the time the horse is shown in such class. (Except for LEADLINE). Ownership shall be defined to include immediate family (see A.1). Horses under lease to, but not owned by any member of the family do not qualify for National youth points. Any youth placing below a youth who does not meet the above will not be moved up in placings. All entries in youth classes shall count toward the overall class points.
1. In order to receive points in the youth division, the youth must own the horse they are exhibiting. Ownership is defined to include parent, stepparent, legal guardian, child, stepchild, brother, sister, half-brother, half-sister, aunt, uncle, niece, nephew, cousin, grandparent, in-laws of the same relationship as stated above and solely family-owned business entities.

2. The ownership requirements of Rules 801.A.1. and 802.C. shall be waived as to any youth domiciled in a country in which there is an International Partner and whose nomination for participation in the Youth World Championship Appaloosa Show through the ApHC International Exchange Program ("visiting youth") **has been approved by the ApHC International Committee** to the extent that a visiting youth may show on an eligible horse without meeting the ownership requirements of Rule 801.A.1. and 802.C., **provided, however, that such participation shall be limited to no more than three (3) classes at one (1) ApHC-approved show and three (3) classes at the Youth World Championship Appaloosa Show during a calendar year, and that such visiting youth are also subject to the following parameters:**
 - a. Youth must be a current ApHC youth member in good standing and be nominated by an International Partner, and there shall be a limit of two nominations each year of visiting youth from each country in which there is an International Partner to participate in the Youth World Championship Appaloosa Show.
 - b. All appropriate entry forms and application deadlines apply.
 - c. Visiting youth may not compete in consecutive years.
 - d. Any visiting youth entry placing in a halter class shall be co-placed and receive a duplicate award, if any, with the regular youth entry in that class who would have placed in that position but for the said visiting youth entry's participation, otherwise classes shall be placed as provided by applicable ApHC Rules.**
 - e. No points shall be awarded to any visiting youth who does not meet the ownership requirements of Rules 801.A.1 or 802.C.**
 - f. No visiting youth may qualify for an overall high point award.**
 - g. Other requirements and/or conditions may be established by the ApHC International Committee and published and/or distributed to visiting youth at **least 10 days before the Youth World Championship Appaloosa Show.**
 - h. As the ApHC International Exchange Program is sponsored, in part, by USLGE funding, the ApHC may not be able to offer this program in any year in which adequate funding is not available.
- B. General rules will apply to the youth division unless otherwise specified in the youth division rules.
- C. Care should be taken so as to avoid jeopardizing the amateur standing of youth contestants through awards made at shows. The offering of money prizes is strictly forbidden in exhibitor judged classes. A youth does not lose amateur status by showing a horse in an open class for someone other than a member of their family since it is the horse that wins the money rather than the youth.
1. Although it is acceptable for a youth to show a horse that is not owned by the youth or a member of their family in the open division, this action could violate Rule 900.G concerning non-pro eligibility.
- D. No stallions, regardless of age, will be permitted in any youth class.
- E. Youth exhibitors may exhibit only one horse in each youth class except that youth exhibitors may exhibit two horses in the following classes only: trail, reining, western riding, jumping, working hunter, cutting, hunter in hand, judged heading, judged heeling, breakaway roping, judged tie-down roping, steer daubing, figure 8 stake race, keyhole race, walk-trot trail, walk-trot Nez Perce stake race, walk-trot camas prairie stump race, walk-trot keyhole and walk-trot figure 8 stake race. **Youth exhibitors may ride a maximum of two horses in Nez Perce stake race and camas prairie stump race when these are timed-only classes.** Points will be maintained for each individual exhibitor-and-horse combination for purposes of calculating year-end high point awards.
- F. A horse may be entered in any or all age divisions, but not more than once in each class. The exhibitor does not have to use the same horse in each event. A horse may be used more than once in a class only if it is used in a separate age division.
- G. Youth exhibitors shall be permitted to participate in the appropriate youth class age division as well as open divisions if they so desire. Married or divorced contestants, regardless of age, are ineligible for competition in youth classes.

H. Exhibitor's birth date shall be duly recorded and entered on the youth membership card. Such youth membership card must be available for inspection at any time during the show.

802. ELIGIBILITY FOR WORLD CHAMPIONSHIP YOUTH SHOW

- A. All persons competing in any World Championship Appaloosa Youth Show must be current members of the Appaloosa Youth Association, and if horse's owner is an adult, said owner must be a member of the ApHC. Persons competing shall be defined to include owners of horses entered or being exhibited by an entered youth, trainers, youth exhibitors and all other participants.
- B. Unrelated Youth cannot show the same horse at the World Championship Youth Show.
- C. In order to compete in youth classes, the youth or member of their family (as outlined in Rule 801.A.I) must own the horse as evidenced by ApHC records prior to the first day of the show. Therefore, all transfers must be completed by the ApHC prior to the first day of the show.

NATIONAL YOUTH AWARDS

803. YOUTH ANNUAL AWARDS

- A. Following are the youth events approved for national points.

Western Showmanship at Halter
English Showmanship at Halter
Western Horsemanship
Hunt Seat Equitation
Hunt Seat Equitation Over Fences
Saddle Seat Equitation
Bareback Horsemanship
Leadline
Trail
Western Pleasure
Western Riding
Hunter Under Saddle
Saddle Seat Pleasure
Hunter Hack
Working Hunter
Heritage
Reining
Breakaway Roping
Judged Tie-Down Roping
Judged Heading
Judged Heeling
Cutting
Steer Daubing
Camas Prairie Stump Race
Nez Perce Stake Race
Keyhole Race
Figure 8 Stake Race
Jumping
Walk-Trot Keyhole Race
Walk-Trot Nez Perce Stake Race
Walk-Trot Camas Prairie Stump Race
Walk-Trot Figure 8 Stake Race
Walk-Trot Western Horsemanship
Walk-Trot Hunt Seat Equitation
Walk-Trot Western Pleasure

Walk-Trot Hunter Under Saddle
Walk-Trot Trail
Walk-Trot Showmanship at Halter
Halter Mares
Halter Geldings
Hunter in Hand, Mares
Hunter in Hand, Geldings
Most Colorful at Halter
Novice Showmanship
Novice Western Horsemanship
Novice Hunt Seat Equitation
Novice Western Pleasure
Novice Hunter Under Saddle
Optional non pointed classes:
Team Penning

- B. Halter must be offered as all-age mares and all-age geldings.

C. Annual High-Point Youth Award:

The youth earning the most national youth points in each youth event approved for national points during one calendar year will be named the year's high-point youth for that event (except those classes listed in 803.C.3). Points are to be computed on the National Point System. Points computed on the National Point system need not be compiled on one horse (except in those classes listed in 803.C.3).

1. Any youth who is high point for the year will receive a year end award, provided the youth has earned at least five points in that event.
2. Ties for year-end high point awards will not be broken.
3. The youth accumulating the most points on the same horse in trail, reining, western riding, jumping, working hunter, cutting, hunter in hand, judged heading, judged heeling, breakaway roping, judged tie-down roping, steer daubing, figure 8 stake race, keyhole race, walk-trot trail, walk-trot Nez Perce stake race, walk-trot camas prairie stump race, walk-trot keyhole and walk-trot figure 8 stake race shall be the high-point champion for the year. Exhibitors may show up to two horses in these classes; however, for purposes of year-end high-point awards only, points will be maintained for each individual exhibitor-and-horse combination.

D. Annual Youth Versatility Award:

A year-end Versatility Award will be given to the youth who earns the most points with one horse in youth activity events in each of the four age divisions; walk-trot, 12 and under, 13 to 15, and 16 to 18 years of age. Points will be compiled on a one horse-one youth basis in youth activity events. Points are to be awarded on the same basis used in the National Points System. Points must have been earned in both Showmanship and Performance with a minimum of five points earned in the lowest division. Points earned in novice and leadline classes do not count toward these awards.

804. YOUTH LIFETIME AWARDS

The following are point-accumulative awards earned over the lifetime of the individual as a youth competitor.

Elective Events: For purposes of calculating youth lifetime awards, elective youth activity events include points earned in novice, leadline, and walk-trot classes. In addition, any additional points earned in excess of the minimum point requirements in any class or category will count as elective points.

A. The categories of events are as follows:

Category I - Showmanship

1. Western Showmanship at Halter
English Showmanship at Halter
Walk-Trot Showmanship at Halter

Category II - Performance

1. Western Horsemanship
Hunt Seat Equitation
Saddle Seat Equitation
Bareback Horsemanship
Hunt Seat Equitation Over Fences
Walk-Trot Western Horsemanship
Walk-Trot Hunt Seat Equitation
2. Camas Prairie Stump Race
Keyhole Race
Figure 8 Stake Race
Nez Perce Stake Race
Jumping
Walk-Trot Keyhole Race
Walk-Trot Nez Perce Stake Race
Walk-Trot Camas Prairie Stump Race
Walk-Trot Figure 8 Stake Race
3. Trail
Western Riding
Western Pleasure
Saddle Seat Pleasure
Hunter Hack
Working Hunter
Hunter Under Saddle
Heritage
Walk-Trot Western Pleasure
Walk-Trot Hunter Under Saddle
Walk-Trot Trail
4. Reining
Timed Tie-Down Roping (points earned prior to 2001)
Breakaway Roping
Cutting
Timed Heading and Heeling (points earned prior to 2001)
Steer Daubing
Judged Tie-Down Roping (points earned in 2001 and forward)
Judged Heading (points earned in 2001 and forward)
Judged Heeling (points earned in 2001 and forward)

Category III - Halter

1. Halter Mares
Halter Geldings
Hunter in Hand, Mares
Hunter in Hand, Geldings
Most Colorful at Halter

B. Youth Achievement Roll:

The purpose of the Youth Achievement Roll is to recognize outstanding youth in performance or halter events. A youth will be advanced to the Youth Achievement Roll after having earned at least 30 points with a minimum of 10 points having been earned in each of at least two categories of performance or halter. Halter points earned prior to 1996 count toward elective youth activity events. Halter points earned in 1996 and forward count toward point requirements in the halter category.

C. Appaloosa Youth Achievement Award:

Fifty (50) points are to be earned for this award. Points must be accumulated under five or more different judges. Of the 50 points, a minimum of 10 must be earned in Showmanship at Halter, a minimum of 20 in Performance or halter events, with a minimum of 10 points having been earned in each of at least two categories (excluding showmanship). The remaining 20 points may be earned in elective youth activity events. Halter points earned prior to 1996 count toward elective youth activity events. Halter points earned in 1996 and forward count toward point requirements in the halter category.

D. Youth Achievement Champion:

175 points are to be earned for this award. These points must be earned under a minimum of five judges. Of the 175 points, a minimum of 35 points must be earned in Showmanship at Halter, a minimum of 70 points must be earned in Performance classes, with a minimum of 18 points earned in three of the four performance sub-categories (other than Showmanship or Halter categories). The remaining 70 points may be won in elective youth activity events. In addition to elective youth activities identified above, any points earned in halter will count toward elective events for this award.

E. Appaloosa Youth Superior Achievement Champion:

350 points are to be earned for this award. These points must be earned in a minimum of five shows under a minimum of five judges. Of the 350 points, a minimum of 105 points must be earned in Showmanship at Halter, a minimum of 140 points must be earned in Performance classes, with a minimum of 35 points earned in three of the four performance subcategories (other than Showmanship or Halter categories). The remaining 105 points may be won in elective youth activity events. In addition to elective youth activities identified above, any points earned in halter will count toward elective events for this award.

805. NATIONAL YOUTH HORSE AWARDS

All youth points count toward the following youth horse awards (excluding showmanship, equitation, novice and leadline classes). Eligible classes are located in Rule 804(A): Category II (2, 3, 4) and category III (1). Only points from 1989 (beginning of the Youth Horse Awards Program) to present will be used for calculation of the following Youth Horse Awards. All youth horse awards will be mailed to the current recorded first listed (in case of joint ownership) owner on record at the ApHC as of December 31.

For purposes of calculating youth horse awards, walk-trot points earned from 2007 forward count toward these awards.

A. Youth Horse Register of Merit (ROM)

Horses are awarded the ROM when they have earned at least 10 points in a youth performance or halter class. A minimum of five points must be earned under three or more judges. Only one ROM is available regardless of youth class age divisions. Points to carry from one age division to another.

B. Youth Champion Horse

A certificate for Youth Champion Horse will be awarded when a horse has earned 50 points, provided at least 15 of these points have been earned in halter and at least 35 points have been earned in at least three different performance classes. At least 10 of the halter points and 10 of the performance points must have been earned under three judges or more.

C. Youth Superior Event Horse

A certificate as Youth Superior Event Horse will be awarded when a horse receives 50 points in a youth halter or performance class.

D. Youth Versatility Champion Horse

A certificate as Youth Versatility Champion Horse will be awarded when a horse has earned five ROMs.

E. Youth Supreme Champion Horse

Youth Supreme Champion Horse will be awarded when a horse has earned at least 100 points, with at least 30 points earned in halter classes and at least 70 points earned in performance classes. No more than 10 points can be from one performance class, and the horse must have at least one ROM in category II- (2), category II- (3) and category II- (4). A minimum of five different judges is required.

806. NOVICE YOUTH PROGRAM

- A. A youth that is eligible for the novice youth program can show in novice youth classes in addition to other youth classes approved for national points.
- B. To be eligible to show in a novice youth class, the youth, as of January 1 of the current year, shall have earned less than a combined total of 20 points in the ApHC and/or any other breed organization –approved or –sponsored shows in the group of youth and novice youth classes that count toward determining novice eligibility in each of the five novice youth classes, excluding walk-trot, leadline, hunter in hand and halter.
 1. Novice points will be accrued to the youth's novice record regardless of whether or not the youth is eligible to earn points as determined by their relationship to the owner of the horse. Once the 20-point total is reached, the youth will no longer be able to show in that novice class at the end of the calendar year. However, these points will not count toward year-end high-point awards or accumulative lifetime awards.
- C. Beginning January 1, 1998, in the event a youth wins a National or World title in any ApHC-sponsored show or in any other equine breed association in a class in which points earned in that class count toward determining the eligibility of the youth in any novice class, that youth will no longer be eligible to compete in that novice class at the end of the calendar year. However, that youth may continue to compete in other novice youth classes if otherwise eligible. Championship wins in walk-trot, leadline, hunter in hand and halter classes will not count toward determining novice eligibility.
- D. Novice youth classes shall not count toward the annual Youth Versatility Award. They will count toward youth accumulative lifetime point awards, but may be used only as elective points.
 1. Novice youth points accumulated while exhibiting a horse that is not owned by a youth or member of their family as defined by youth ownership rules will not count toward year-end high-point awards or accumulative lifetime awards.
- E. See Rule 803 for a listing of novice youth classes. Year-End high point awards will be given in the five novice classes approved for national points.

807. YOUTH WALK-TROT DIVISION

- A. This class is limited to exhibitors 10 years and under who do not participate in any approved classes except Showmanship, Halter, Heritage and classes contained in the walk-trot division which include:
 - a. Walk-Trot Showmanship
 - b. Walk-Trot Game Classes (Camas Prairie Stump Race, Nez Perce Stake Race, Keyhole Race, Figure 8 Stake Race)
 - c. Walk-Trot Equitation Classes (Western Horsemanship, Hunt Seat Equitation)
 - d. Walk-Trot Pleasure Classes (Western Pleasure, Hunter Under Saddle)
 - e. Walk-Trot Trail
- B. Youth exhibitors will not be allowed to show in walk-trot classes after exhibiting in a three gaited class at ApHC-sponsored or -approved events or shows.

Rules 808-899 not assigned.

NON-PRO PROGRAM

900. ENROLLMENT AND PARTICIPATION RULES.

A. ELIGIBILITY: All individuals entering approved non-pro classes must hold a current ApHC non-pro card. In order to be enrolled in the Appaloosa non-pro program, an individual must be 19 years of age or older or must be married and ineligible for Appaloosa Youth Association, and be a member of the ApHC.

B. For horse show purposes, the age of the individual on January 1 shall be maintained throughout the entire year. Persons born on January 1 shall assume the greater age of that date.

C. The fee for enrollment in the Appaloosa non-pro program is \$10. Points will be counted only for individuals enrolled in the program. All requirements must be in the ApHC office before points will be counted.

D. Non-Pro memberships are non-refundable and non-transferable.

E. Enrollment must be applied for annually. The annual renewal fee shall be \$10.

F. Participants will be issued a non-pro card. This card must be presented when entering all non-pro classes or presented at any time requested by the show management.

G. NON-PRO DEFINED.

The individual MUST meet the definition of a non-pro, as follows:

1. Has not ever engaged in any activities which would make him/her a professional. A professional is an individual who:
 - a. Accepts remuneration for riding, driving, showing in halter, training, schooling, conducting clinics or seminars, or instructing in equitation or horse training or judging.
 - b. Performs the above listed activities for which another person in his/her family or a corporation, which a member of his/her family controls, will receive remuneration.
 - c. Performs such activities while accepting remuneration for employment in another capacity for an employer or member of said employer's family who owns, boards or trains the involved horses.
 - d. Rides, drives or shows in halter in horse shows any horse for which he/she or a member of his/her family accepts remuneration for boarding or training.
 - e. Accepts prize money in Equitation or Showmanship classes.
 - f. Accepts remuneration in the form of payment of entry fees, or any expenses for the person or the horse with which the Non-Pro competes, by any person other than the non-pro or the non-pro's spouse, child, stepchild, legal ward, father mother, stepparent, sister, brother, grandparent, grandchild or legal guardian.
 - g. Holds judging credentials with any equine organization or receives remuneration for judging either in the form of a salary, perks or as reimbursement for expenses.
2. Non-pro status shall not be affected by the following:
 - a. Writing of books or articles pertaining to horses.
 - b. Accepting payment for stewarding.
 - c. Having the occupation of veterinarian or farrier, or owning a tack shop or breeding or boarding stable.
 - d. Certification as an instructor in equitherapy by North American Riding for the Handicapped Association (NARHA) or similar organizations. Information on approved organizations, other than NARHA, shall be submitted to ApHC for review and approval with regard to non-pro status. The excepted instructor shall teach only students enrolled with an approved organization or prescribed such rehabilitation by a licensed medical doctor. Non-pros excepted under this provision shall file such certification with the ApHC prior to competing in non-pro events at ApHC-approved and/or –sponsored shows.

H. CHANGE OF STATUS.

A professional continues to be such until he/she has received non-pro status from the ApHC Show Department. Any person who has been a professional and who desires to be reclassified as a non-pro on the grounds that he/she no longer engages in the activities which made him/her a professional, must so notify the ApHC in writing. The applicant must have not engaged in such professional activities for a period of at least three years prior to the date of application in order to obtain non-pro status. The burden of proving non-pro status is on the applicant, who must file a notarized application supported by two or more notarized letters from ApHC current active members outlining the applicant's activities during the non-professional period and testifying that the applicant has not engaged in any activities which would make him/her a professional during said time period. Any exhibitor having received prize money in any Equitation or Showmanship class who wishes to obtain non-pro status must file the same application. A professional reclassified as a non-pro is not eligible to show as a novice.

- I. A non-pro who shows for a person other than a member of his/her family may not show in a class restricted to non-pros at the same show, **with the exceptions that a non-pro may assist showing a horse for a special needs exhibitor as defined by Rule 608.K., and that a non-pro may exhibit a non-owned horse in a non-pro walk-trot class.**
- J. Any horse ridden or handled by a non-pro in non-pro events must be wholly owned by such non-pro exhibitor or non-pro handler and/or such non-pro exhibitor's or non-pro handler's spouse, child, step-child, legal ward, father, mother, stepparent, sister, brother, aunt, uncle, niece, nephew, grandparent, grandchild, legal guardian, in-laws of the same relationship as stated above or solely family owned business entity.
 1. The ownership requirements of Rules 900.J. and 907 are waived as to any non-pro domiciled in the country in which there is an International Affiliate and who has been approved through the ApHC International Exchange Program ("visiting non-pro") to the extent that the visiting non-pro may show on an eligible horse without meeting the ownership requirements of this Rule 900.J. in up to three (3) classes at either the National Appaloosa Show or the World Championship Appaloosa Show and at one (1) ApHC-approved show during a calendar year, and subject also to the following parameters:
 - a. Limit of two nominations from each country for each of the current-year National and World Shows with no waiver of entry fees, only a waiver of ownership requirements.
 - b. All appropriate entry forms and application deadlines apply.
 - c. Visiting non-pro must arrange for the horses that they will exhibit and supply all of their own travel, lodging and food.
 - d. Visiting non-pro must pay full entry fees.
 - e. Visiting non-pro may not compete in consecutive years to allow an equal chance for all that desire to participate.
 - f. There is a limit of 2 nominations per country, per event, per event year.
 - g. Non-pro must be a current ApHC non-pro member in good standing and must be nominated by a recognized International Partner.
 - h. Such other requirements and/or conditions as may be established by the ApHC International Committee and published and/or distributed to visiting non-pros.
- K. The non-pro and/or family member who actually owns the horse with which the non-pro will participate in non-pro events, agrees to provide, upon request from the ApHC, such documentation or other proof as requested by the ApHC to support the representations of sole economic ownership of the horse or horses exhibited by the non-pro in non-pro events. Failure to promptly furnish such documentation upon request may be cause for possible disciplinary action under ApHC disciplinary rules.

L. For purposes of a non-pro's eligibility, the term "owned" as used in this rule means bona fide legal ownership.

M. Any non-pro found guilty of violating any of the non-pro eligibility qualifications (Rule 900.A through L) shall, unless an alternate agreement is reached per Rule 20.D.5 DISCIPLINARY PROCEDURE:

1. For the first violation, be suspended from the ApHC for six months, be fined a minimum of \$250 and lose all points from time of violation of eligibility;
2. For the second violation, be suspended for one year, be fined a minimum of \$750 and lose all points from time of violation of eligibility;
3. For the third violation, be suspended for life and lose all points from time of violation of eligibility.

901. NON-PRO CLASSES

- A. Following is a list of non-pro classes approved for National points. Letters listed behind each class indicate the divisions available for each class. These letters are: NP = Non-Pro; 35 = 35 & Over Non-Pro; MS = Masters Non-Pro; NV = Novice Non-Pro; W/T = Walk/Trot.
- B. For purposes of calculating non-pro lifetime awards:
 1. Classes that are considered working events or equitation classes are so noted following the list of divisions,
 2. The class list is divided into Western, English and Other classes.
 3. Points earned in novice classes don't count toward any awards except those designated for novice non-pros only.
 4. Points earned in non-pro yearling long line are accumulated only for the horse's and non-pro's performance records. Points earned in yearling long line don't count toward any annual or lifetime non-pro or annual or lifetime non-pro horse awards except that points earned in non-pro yearling long line may count toward a non-pro ROM.
 5. Points earned in non-pro walk-trot classes may not be used toward any other awards, i.e. open, non-pro, year-end, or high point awards.

Western Classes

Showmanship at Halter (NP, 35, MS, NV)
Bareback Horsemanship (NP, NV) - Equitation
Western Horsemanship (NP, 35, MS, NV, W/T) - Equitation
Western Pleasure (NP, 35, MS, NV, W/T)
Trail (NP, MS, NV, W/T) - Working Event
Western Riding (NP, MS, NV) - Working Event
Reining (NP, MS, NV) - Working Event
Cutting (NP, NV) - Working Event
Timed Tie-Down Roping (NP, NV) - Working Event
(prior to 2001, 2008 and later)
Timed Heading and Heeling (NP, NV) - Working Event
(prior to 2001, 2008 and later)
Steer Daubing (NP, NV) - Working Event
Judged Tie-Down Roping (NP, NV) - Working Event
(beginning in 2001)
Judged Heading (NP, NV) - Working Event (beginning in 2001)
Judged Heeling (NP, NV) - Working Event (beginning in 2001)
Working Cow Horse (NP, NV) - Working Event
Breakaway Roping (NP, NV) - Working Event

English Classes

Working Hunter (NP, NV) - Working Event
Jumping (NP, NV) - Working Event
Hunter Hack (NP, NV) - Working Event
Hunt Seat Equitation (NP, 35, MS, NV, W/T) - Equitation
Hunt Seat Equitation Over Fences (NP, NV) - Equitation
Hunter Under Saddle (NP, 35, MS, NV, W/T)

Saddle Seat Pleasure (NP, NV)
Saddle Seat Equitation (NP, NV) - Equitation
Pleasure Driving (NP, NV)

Other Classes

Nez Perce Stake Race (NP, NV, W/T) - Working Event
Camas Prairie Stump Race (NP, NV, W/T) - Working Event
Keyhole Race (NP, NV, W/T) - Working Event
Figure 8 Stake Race (NP, NV) - Working Event
Halter Mares (NP)
Halter Geldings (NP)
Halter Stallions (NP)
Hunter in Hand, Stallions (NP)
Hunter in Hand, Mares (NP)
Hunter in Hand, Geldings (NP)
Most Colorful at Halter (NP)
Yearling longeline (points accumulated for performance record only)

Optional Non-Pointed Classes:

Team Penning
Western Riding (35)
Trail (35)

C. 35 & Over Non-Pro:

1. Open to non-pro's 35 years old and over as of January 1 of the current year who meet all non-pro requirements per Rule 900 (A-M).

D. Masters Non-Pro:

1. Open to non-pro's 50 years old and over as of January 1 of the current year who meet all non-pro requirements per Rule 900 (A-M).

E. Non-Pro Walk-Trot:

1. Eligibility. All non-pros are eligible to ride in these classes without regard to number of points earned or age of exhibitor.
2. Ownership of Horse.
 - a. For the walk-trot division classes, ownership requirements of the horse are waived at ApHC-approved regional shows.
 - b. For the walk-trot division classes, ownership requirements of the horse are not waived at ApHC-sponsored shows.
3. Non-pro walk-trot classes will be judged in accordance with ApHC walk-trot show rules.
4. There are no restrictions on how long a non-pro exhibitor may show in walk-trot classes.
5. A non-pro exhibitor cannot show in the walk-trot classes and three-gaited classes at the same show.
6. These classes are limited to non-pros who do not participate in any approved classes at the same show except Showmanship, Halter, Hunter in Hand, Heritage, Yearling Longe Line, Pleasure Driving and non-pro walk-trot classes which include:
 - a. Walk-Trot games classes (Camas Prairie Stump Race, Nez Perce Stake Race, Keyhole Race)
 - b. Walk-Trot Western Horsemanship, Walk-Trot Hunt Seat Equitation
 - c. Walk-Trot Pleasure Classes (Western Pleasure, Hunter Under Saddle)
 - d. Walk-Trot Trail

7. Points earned in the walk-trot program may not be used toward any other awards, i.e. open, non-pro, year-end, or high point awards.

8. Points are accumulated on the individual exhibitor provided they meet non-pro ownership requirements as listed in 900.J.

E. To be eligible to compete in any novice non-pro classes, the non-pro must meet eligibility requirements as contained in Rule 906.

902. NATIONAL POINTS

- A. Points will be counted from approved non-pro classes at all ApHC approved shows. Shows are required to offer at least two Western and two English classes for non-pros 19 and over, in order to be approved to hold non-pro classes.
- B. Points will be counted according to the current national point system.
- C. For all non-pro exhibitor awards (except year-end high-point awards), points will be maintained for the individual exhibitor. The exhibitor may use any number of horses. See 902.E. and 903.D. for rules regarding year-end high-point awards.
- D. For non-pro horse awards, points will be kept on each horse used in the non-pro program.
- E. For year-end high-point awards in trail, western riding, reining, cutting, keyhole race, figure 8 stake race, steer daubing, judged tie-down roping, judged heading, judged heeling, timed tie-down roping, timed heading and healing, working cow horse, breakaway roping, working hunter, hunter in hand and jumping points will be maintained for each individual exhibitor-and-horse combination.

903. NON-PRO EXHIBITOR ANNUAL AWARDS

The Non-Pro Award System is designed to award non-pros who have proven their superiority in the fields of competition in ApHC non-pro events. All non-pros must be current members in good standing with the ApHC and must hold a current non-pro card.

A. Non-Pro Medal:

1. Will be awarded to all winners in ApHC-approved nationally pointed non-pro classes at both the World Championship Appaloosa Show and the National Appaloosa Show, provided that at least three horses are shown in the class. Any non-pro who is high-point at the end of the year through the national point system will receive credit for the proper category of medal, provided that the non-pro has earned at least five points in that event and provided that points have been earned under 3 or more judges. Ties for year-end high point awards will not be broken.
2. Medals to be awarded as follows:
 - a. Bronze - first category or first medal
 - b. Silver- second category
 - c. Gold- third category
 - d. Platinum- for repeat wins in any category in which a medal has been previously awarded.
3. Medal Categories:
 - a. Showmanship and Equitation.
 - b. Halter (Mares, Geldings, Stallions) Pleasure (English, Western, and Pleasure Driving and Yearling Longeline-World Show only)
 - c. Working classes (Games, Cattle, Working Hunter, Jumping, Reining, Hunter Hack, Trail, Western Riding).
4. Non-Pro classes, 35 & Over Non-Pro classes, Masters Non-Pro classes, Novice Non-Pro Showmanship, Novice Non-Pro Western Pleasure, Novice Non-Pro Western Horsemanship, Novice Non-Pro Hunter Under Saddle, Novice Non-Pro Trail and Novice Non-Pro Hunt Seat Equitation are medal classes.

B. Western Rider of the Year/English Rider of the Year

1. To be awarded to the individual in each division accumulating the most points in the specific group of classes (Western or English) as follows: Points must have been earned in at least four different classes; a minimum of 10 points must have been earned in Equitation classes; total points must have been earned in at least three different shows under three different judges, with points to be counted from all classes in the group whether or not each individual class points have been earned in three shows. If the exhibitor with the most points fails to meet these qualifications, the award will not be presented. Masters, 35 & Over, Novice and Walk/Trot classes don't count toward this award.

C. Non-Pro Superior Champion Annual Award

1. To be awarded to the non-pro accumulating the most points during the year in all classes, as follows: Points must have been earned in both Western and English classes; points must have been earned in at least five different classes, including at least one working event; a minimum of 20 points must have been earned in Equitation classes; total points must have been earned in at least three different shows under three different judges, with points to be counted from all classes whether or not each individual class points have been earned in three shows. If exhibitor with the most points fails to meet these qualifications, the award will not be presented. Masters, 35 & Over, Novice and Walk/Trot classes don't count toward this award.

D. Annual High Point (event) Awards

1. The individual accumulating the most points in each class shall be the ApHC year-end high-point champion and will receive an award provided that the non-pro has earned at least five points in that class. Points must have been earned under at least three different judges. If the exhibitor accumulating the most points does not meet the three-judge qualification, the awards will not be presented. In addition to all non-pro, masters non-pro and 35-&-over non-pro classes, year-end high-point awards will be given in novice showmanship, novice western pleasure, novice western horsemanship, novice hunter under saddle, novice trail and novice hunt seat equitation.
 - a. The individual accumulating the most points in each class (except those classes listed in 903.D.1.b.) shall be the ApHC champion for the year.
 - b. The individual accumulating the most points on the same horse in trail, western riding, reining, cutting, keyhole race, figure 8 stake race, steer daubing, judged tie-down roping, judged heading, judged heeling, working cow horse, breakaway roping, working hunter, hunter in hand and jumping shall be the ApHC champion for the year. Exhibitors may show more than one horse in these classes; however, for purposes of year-end high-point awards only, points will be maintained for each individual exhibitor-and-horse combination.

E. Annual Non-Pro Versatility Award:

A year-end award will be given to the non-pro who earns the most points with one horse in each division of non-pro events, excluding novice. Points will be compiled on a one-horse/one-rider basis. Points are awarded on the same scale used for the national point system. Points must have been earned in both showmanship and performance with a minimum of five points earned in the lowest division.

1. Points earned in regular non-pro classes only count toward the non-pro versatility award.
2. Points earned in 35 & over non-pro classes only count toward the non-pro 35 & over versatility award. This award will be given on a trial basis in 2011-2015.
3. Points earned in masters non-pro classes only count toward the masters non-pro versatility award. This award will be given on a trial basis in 2011-2015.

904. NON-PRO EXHIBITOR LIFETIME AWARDS

A. Awards of Merit.

1. All exhibitors enrolled in the non-pro program, in any division, are eligible to receive an award of merit for an individual class when 20 points have been earned in that event. Points must have been earned under at least three different judges. This award is earned separately in Non-Pro, 35 & Over Non-Pro and Masters Non-Pro classes.

B. Non-Pro Supreme Champion Lifetime Award

1. To be awarded to any non-pro who earns a minimum of 250 points. Points must have been earned in both Western and English classes, with no less than 75 points in each group of classes. In addition, and including the 75 point Western and English groups minimums, the individual must have earned at least 25 points in Showmanship at Halter, 100 points in Equitation, and 50 points in working events. The remaining 75 points may be earned in any non-pro events. Novice and Walk/Trot Non-Pro points do not count toward this award. However, 35 & Over Non-Pro and Masters Non-Pro points will count toward point totals.

905. NON-PRO HORSE AWARDS

- A. All non-pro points will count toward the following non-pro horse awards (excluding showmanship, equitation, novice and Walk/Trot classes). Only points from 1990 (the beginning of the Non-Pro Awards Program) to present will be used for calculation of the following Non-Pro horse awards. All non-pro horse awards will be mailed to the current recorded first listed (in cases of joint ownership) owner on record at the ApHC as of December 31.

1. Points earned in non-pro yearling longeline are only eligible to count toward a non-pro ROM.

- B. Only one award is available regardless of Non-Pro, 35 & Over and Masters Non-Pro divisions. Points carry from one division to another.

C. Non-Pro Horse Register of Merit (ROM)

1. Horses are awarded the ROM when they have earned at least 10 points in a non-pro, 35 & over non-pro, and masters non-pro performance or a non-pro halter class. A minimum of five points must be earned under three or more judges. Only one ROM is earned in each class, regardless of the non-pro division. Horses are only eligible to receive 1 halter ROM.

D. Non-Pro Champion Horse

1. A certificate for Non-Pro Champion Horse will be awarded when a horse has earned 50 points in non-pro, 35 & over non-pro and masters non-pro classes, provided at least 15 of these points have been earned in halter and at least 35 points have been earned in at least three different performance classes. At least 10 of the halter points and 10 of the performance points must have been earned under three judges or more.

E. Non-Pro Superior Event Horse

1. A certificate for Non-Superior Event Horse will be awarded when a horse receives 50 points in a non-pro, 35 & over non-pro and masters non-pro halter or performance class.

F. Non-Pro Versatility Champion Horse

1. A certificate as Non-Pro Versatility Champion Horse will be awarded when a horse has earned five ROMs in non-pro, 35 & over non-pro and masters non-pro classes.

G. Non-Pro Supreme Champion Horse

1. Non-Pro Supreme Champion Horse will be awarded when a horse has earned at least 100 points in non-pro, 35 & over non-pro and masters non-pro classes, with at least 30 points earned in halter classes and at least 70 points earned in performance classes. No more than 10 points can be from one performance class, and the horse must have at least one ROM in each of the three categories of performance classes (categories II-2, II-3, II-4). A minimum of five different judges is required.

H. Following are the classes and categories used in calculating non-pro horse awards.

Category I - Showmanship

1. Western Showmanship at Halter

Category II - Performance

1. Western Horsemanship
 - Hunt Seat Equitation
 - Saddle Seat Equitation
 - Bareback Horsemanship
 - Hunt Seat Equitation Over Fences
2. Camas Prairie Stump Race
 - Keyhole Race
 - Figure 8 Stake Race
 - Nez Perce Stake Race
 - Jumping
3. Trail
 - Western Riding
 - Western Pleasure
 - Saddle Seat Pleasure
 - Hunter Hack
 - Working Hunter
 - Hunter Under Saddle
 - Pleasure Driving
4. Reining
 - Timed Tie-Down Roping (prior to 2001, 2008 and later)
 - Cutting
 - Timed Heading & Heeling (prior to 2001, 2008 and later)
 - Steer Daubing
 - Judged Tie-Down Roping (beginning in 2001)
 - Judged Heading (beginning in 2001)
 - Judged Heeling (beginning in 2001)
 - Working Cow Horse
 - Breakaway Roping

Category III - Halter

1. Halter Mares
 - Halter Stallions
 - Halter Geldings
 - Hunter in Hand, Stallions
 - Hunter in Hand, Mares
 - Hunter in Hand, Geldings
 - Most Colorful at Halter

906. NOVICE NON-PRO PROGRAM

A. A Novice Non-pro must have a Non-pro card and meet all Non-pro requirements. To be eligible for Novice Non-pro status in any class, the applicant must have earned less than 20 points in that class in the ApHC and/or any other breed organization as of January 1 of current year in Youth, Novice Youth, Non-pro, 35 & Over Non-pro, Masters Non-pro and Novice Non-pro classes. Points earned in Youth Leadline, Youth Walk-Trot, Non-Pro Walk/Trot, Youth and Non-pro Halter do not count in determining Novice Non-pro eligibility. Former professionals reclassified as Non-pros are not eligible for Novice classes.

1. Beginning January 1, 1996, when a Novice Non-pro wins an ApHC National or World class title or a class title in any other equine breed association, they will no longer be eligible for Novice Non-pro in that class at the end of that calendar year (excluding halter and hunter in hand classes).
- B. Novice classes will be judged in accordance with ApHC rules. For each Novice Non-pro class held at a show, the corresponding Non-pro class must also be offered.
- C. No prize money or payback will be awarded in novice classes. Points earned in the novice program may not be used toward any other awards; i.e., open, non-pro, year-end, or high point awards.
- D. There is a novice class for each corresponding non-pro class (except halter) however, awards will only be given to novice year-end high point class winners in western pleasure, showmanship, trail, hunter under saddle, western horsemanship and hunt seat equitation. All other class winners will receive certificates provided that they have accumulated at least 5 points.
- E. Points are accumulated on the individual exhibitor. Novice non-pros may concurrently enter any other non-pro, 35 & over non-pro or masters non-pro classes.
- F. To be eligible to compete in any novice non-pro class, the non-pro must meet eligibility requirements as contained in Rule 906.

907. ELIGIBILITY FOR NATIONAL AND WORLD SHOWS

- A. All persons competing in non-pro events must be current ApHC members, must be enrolled in the ApHC non-pro program and must meet all eligibility requirements to compete as a non-pro in non-pro events.
- B. In order to compete in non-pro events, the non-pro or member of their family (as outlined in Rule 900.J) must wholly own the horse as evidenced by ApHC records prior to the first day of the show. Therefore, all transfers must be completed by the ApHC prior to the first day of the show.
- C. Beginning in 2007, non-pros must qualify to exhibit at the World Championship Appaloosa Show by earning one national point in any age division (19 & over, 35 & over, masters) of a non-pro class which will entitle the non-pro to exhibit in any age division of that class, with the exception of **classes listed under Optional Non-Pointed Classes, Non-Qualifying Classes, and halter**. In halter, non-pros must earn one national point in any non-pro halter sex division (not per class) in order to be eligible to compete in any halter class in that sex division, excluding weanlings competing in weanling halter classes and weanlings and yearlings competing in hunter in hand classes.
 1. Novice classes are non-qualifying classes.
 2. Points earned September 1 through August 31 of the following year will count toward qualification for that year's World Championship Appaloosa Show.
 3. Each non-pro World Show Champion will automatically qualify to compete in that class at the next World Show.
 4. An exception may be made to the one (1) national point requirement if it is documented on forms requested from and provided by the ApHC and submitted by the non-pro by the World qualifying point cutoff deadline that the non-pro was entered and attempted in good faith to earn points under at least five (5) different judges in any age division (19 & over, 35 & over, masters) for that class during that qualifying year but could not earn the required one (1) point due to lack of other entrants in that specific class. The non-pro must have a non-pro qualification waiver signed by the show secretary of each show which must be submitted along with that non-pro's World Show entry form to ApHC office by the pre-entry deadline.
 5. Stipulations for qualifying to compete in non-pro classes at the World Championship Show are included in the following list:

Key:

NP = Non-Pro, 19 & Over

35 = Non-Pro, 35 & Over

MS = Non-Pro, Masters

Western Classes # Points Required

Showmanship at Halter (NP, 35 and/or MS).....	1
Bareback Horsemanship (NP)	1
Western Horsemanship (NP, 35 and/or MS).....	1
Western Pleasure (NP, 35 and/or MS).....	1
Trail (NP, MS)	1
Western Riding (NP, MS)	1
Reining (NP, MS).....	1
Cutting (NP)	1
Timed Tie-Down Roping (NP)	1
Timed Heading and Heeling (NP).....	1
Steer Daubing (NP)	1
Judged Tie-Down Roping (NP)	1
Judged Heading (NP)	1
Judged Heeling (NP)	1
Working Cow Horse (NP).....	1
Breakaway Roping (NP)	1

English Classes # Points Required

Hunter Hack (NP).....	1
Hunt Seat Equitation (NP, 35 and/or MS).....	1
Hunter Under Saddle (NP, 35 and/or MS).....	1
Saddle Seat Pleasure (NP)	1
Saddle Seat Equitation (NP)	1

Games Classes # Points Required

Nez Perce Stake Race (NP)	1
Camas Prairie Stump Race (NP)	1
Keyhole Race (NP).....	1
Figure 8 Stake Race (NP)	1

Halter Classes.....# Points Required

Halter Mares	1
Halter Geldings	1
Halter Stallions	1

(Qualification is required for yearling, two-year-old, three-year-old and aged classes only—non-pros are not required to qualify weanlings to compete in non-pro weanling halter classes.)

Hunter in Hand, Stallions	1
Hunter in Hand, Mares	1
Hunter in Hand, Geldings	1

(Qualification is required for two-year-old and older horses – non-pros are not required to qualify weanling or yearling horses to compete in non-pro hunter in hand classes.)

Most Colorful at Halter	1
-------------------------------	---

(Non-pros must qualify all entries regardless of the age of the horse)

Optional Non-Pointed Classes:

Team Penning
Yearling Longeline

Non-Qualifying Classes:

Working Hunter (NP)
Jumping (NP)
Hunt Seat Equitation Over Fences (NP)
Pleasure Driving (NP)

Rules 908-999 not assigned.

1000. WORLD'S BEST APPALOOSA

While only the best Appaloosas are invited to participate in the World Show, an even smaller group of horses can compete for the title of World's Best Appaloosa.

- A. In order to compete for this title, a horse must enter and compete in a minimum of three categories to be eligible. The horse's top two World's Best point earning placings in each of five categories will be used to calculate placing. In addition, the horse must earn World's Best points in a minimum of two categories.
- B. Categories for tabulation of World's Best Appaloosa are listed below. ONLY the following classes will be used for tabulation of this award at the World Championship Appaloosa Show.

I. Halter (all age divisions except weanling, get of sire, produce of dam)
Most Colorful at Halter
Hunter in Hand

II. Junior Western Pleasure
Senior Western Pleasure
Junior Hunter Hack
Senior Hunter Hack
Pleasure Driving
Junior Hunter Under Saddle
Senior Hunter Under Saddle
Junior Saddle Seat Pleasure
Senior Saddle Seat Pleasure

III. Junior Reining
Senior Reining
Junior Western Riding
Senior Western Riding
Junior Trail
Senior Trail
Open Jumper
Working Hunter

IV. Camas Prairie Stump Race
Rope Race
Nez Perce Stake Race
Keyhole Race
Figure 8 Stake Race

V. Steer Daubing
Junior Cutting
Senior Cutting
Heading & Heeling
Junior Judged Tie-Down Roping
Senior Judged Tie-Down Roping
Junior Judged Heading

Senior Judged Heading
 Junior Judged Heeling
 Senior Judged Heeling
 Timed Tie-Down Roping
 Junior Working Cow Horse
 Senior Working Cow Horse

C. THE FOLLOWING TABLE WILL BE USED FOR TABULATING WORLD'S BEST POINTS:

# of horses	1st	2nd	3rd	4th	5th	6th	7th	8th	9th	10th
3-5	1									
6-8	2	1								
9-11	3	2	1							
12-14	4	3	2	1						
15-17	5	4	3	2	1					
18-20	6	5	4	3	2	1				
21-23	7	6	5	4	3	2	1			
24-26	8	7	6	5	4	3	2	1		
27-29	9	8	7	6	5	4	3	2	1	
30 & Over	10	9	8	7	6	5	4	3	2	1

D. Ties will be broken in the following manner:

- 1) The horse placing in the greater number of categories in first through tenth place, then
- 2) The horse placing in the greater number of classes listed above in first through tenth place, then
- 3) The horse defeating the greater number of entries in the classes listed above.

Length Conversion Factors

To convert from	to	multiply by
inch (in)	millimeter (mm)	25.4
inch (in)	centimeter (cm)	2.54
inch (in)	meter (m)	0.0254
foot (ft)	meter (m)	0.3048
mile	kilometer (km)	1.609347