

# Saentis Color Show

## Greenhorn Showmanship

Show Date: 05-20-2017

w w w . H o r s e S h o w P a t t e r n s . c o m

w w w . H o r s e S h o w P a t t e r n s . c o m

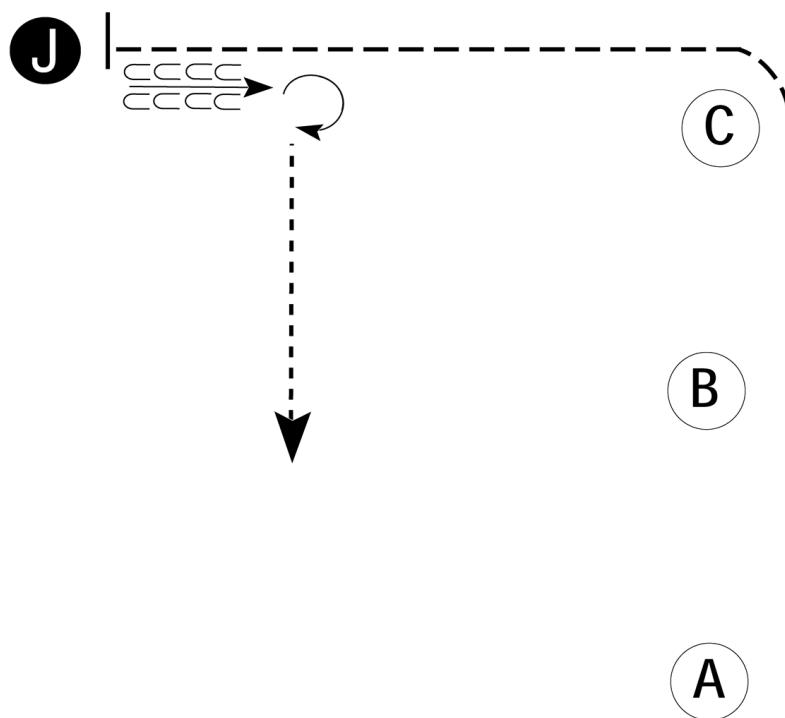

Be ready at A.

1. Walk to B.
2. Trot to and around C to judge.
3. Stop and set up for inspection.
4. When dismissed back approximately one horse length.
5. Perform a 270 degree turn and walk straight away.

Follow the instructions of your ring steward.

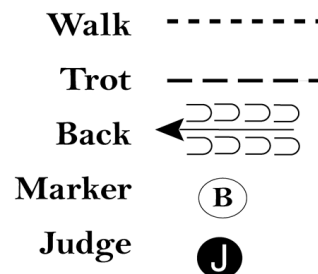

[S/1-39]

Pattern Provided by:

*ApHCS*

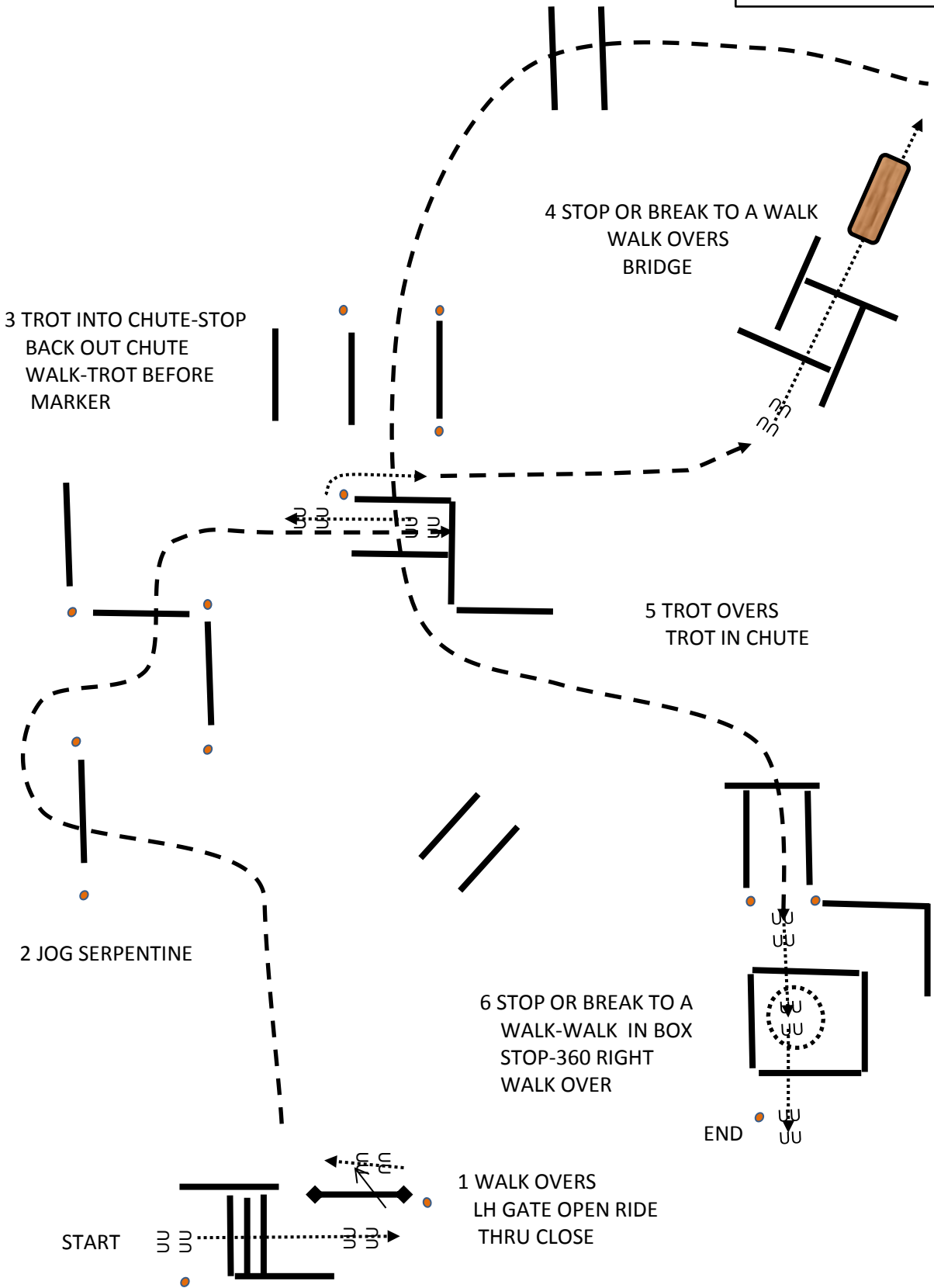

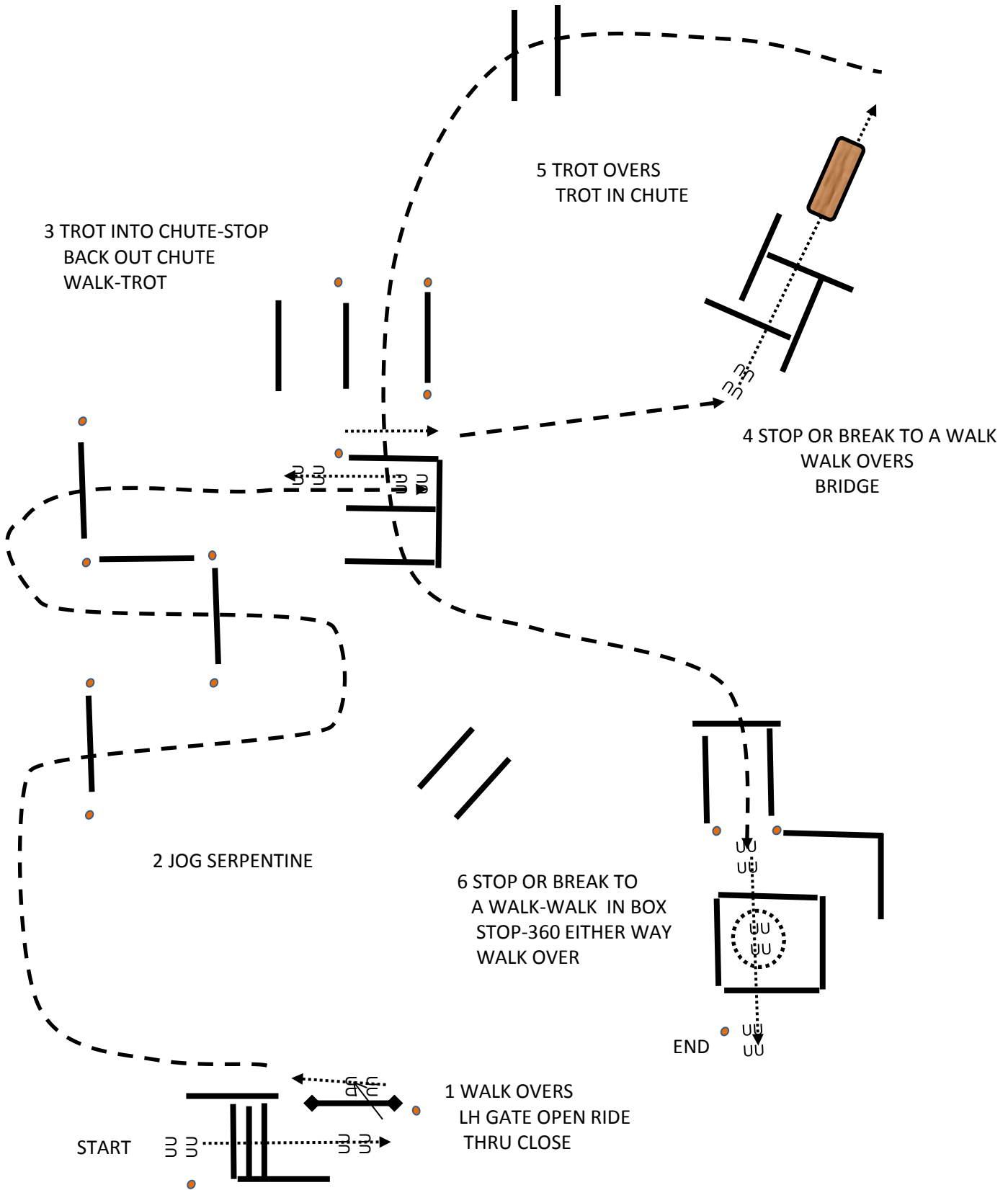

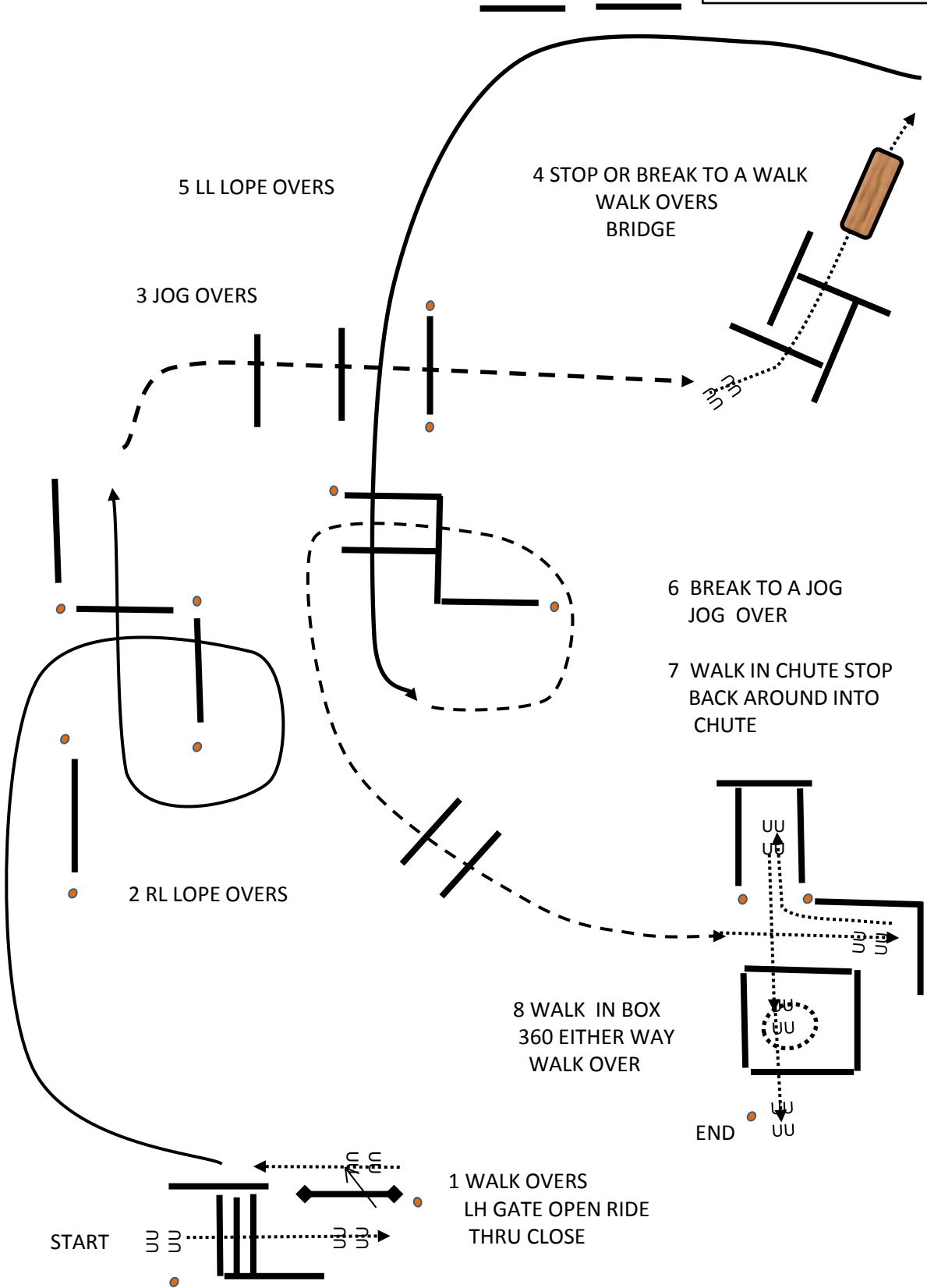

START

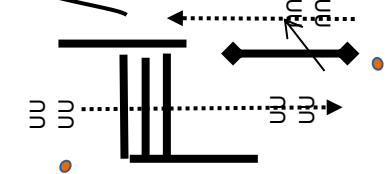

1 WALK OVERS  
LH GATE OPEN RIDE  
THRU CLOSE

2 RL LOPE OVERS

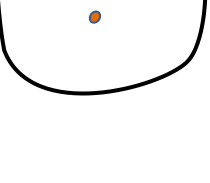

3 JOG OVERS

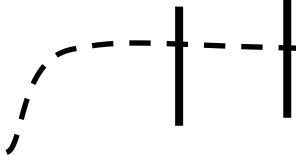

5 LL LOPE OVERS

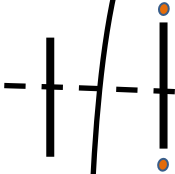

4 STOP OR BREAK TO A WALK  
WALK OVERS  
BRIDGE

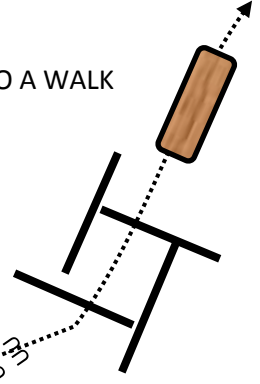

6 BREAK TO A JOG  
JOG OVER

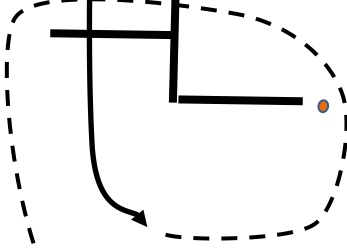

7 WALK IN CHUTE STOP  
BACK AROUND INTO  
CHUTE

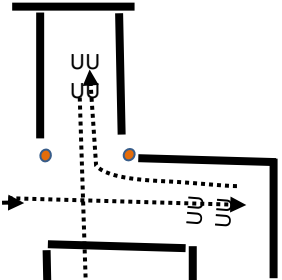

8 WALK IN BOX  
360 EITHER WAY  
WALK OVER

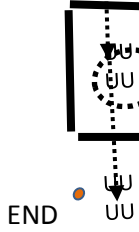

END

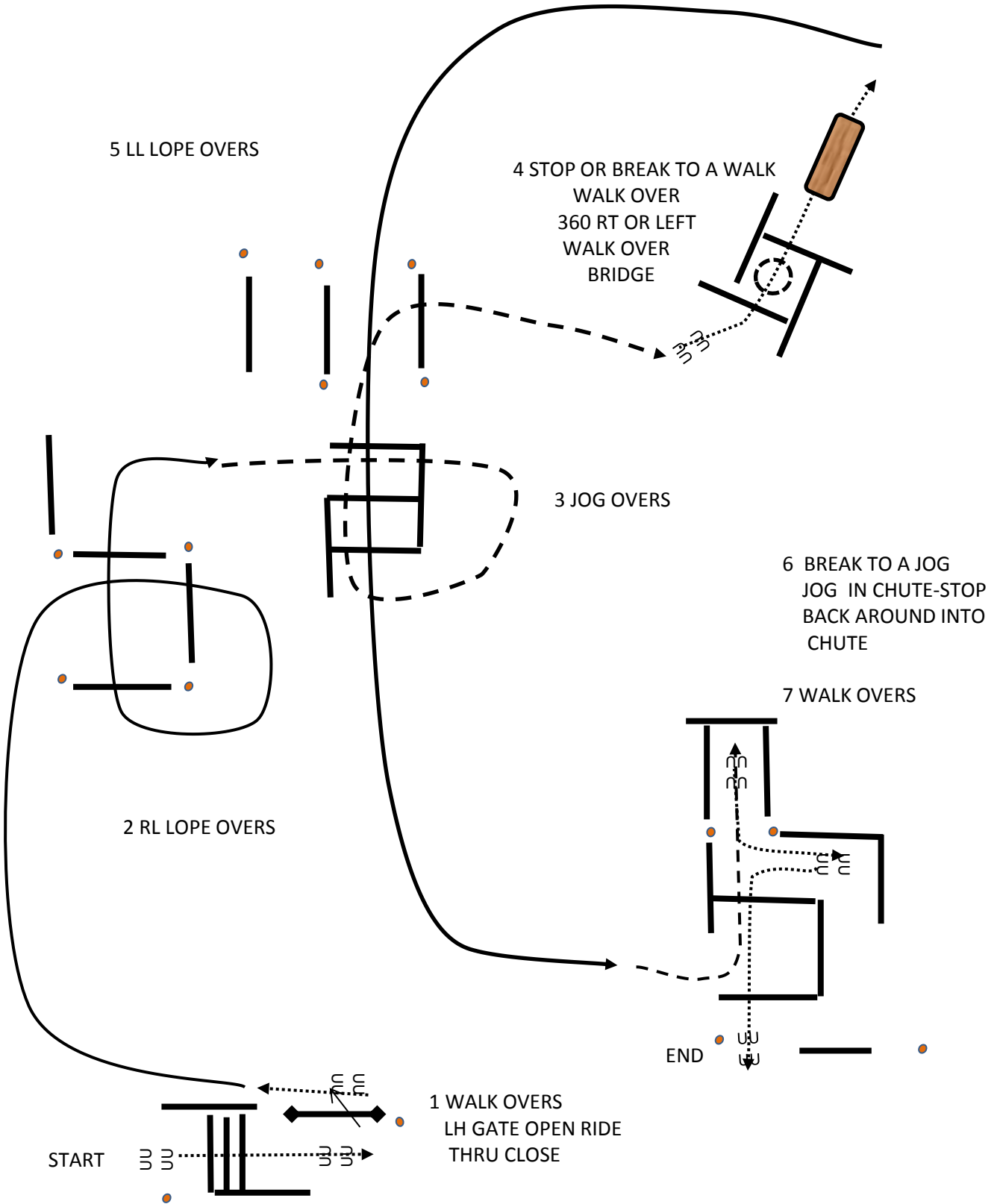

5 LL LOPE OVERS

4 STOP OR BREAK TO A WALK  
WALK OVER  
360 RT OR LEFT  
WALK OVER  
BRIDGE

3 JOG OVERS

6 BREAK TO A JOG  
JOG IN CHUTE-STOP  
BACK AROUND INTO  
CHUTE

7 WALK OVERS

2 RL LOPE OVERS

1 WALK OVERS  
LH GATE OPEN RIDE  
THRU CLOSE

START

END

# Saentis Color Show

## OKV Country Westernhorse

Show Date: 05-20-2017

w w w . H o r s e S h o w P a t t e r n s . c o m

w w w . H o r s e S h o w P a t t e r n s . c o m

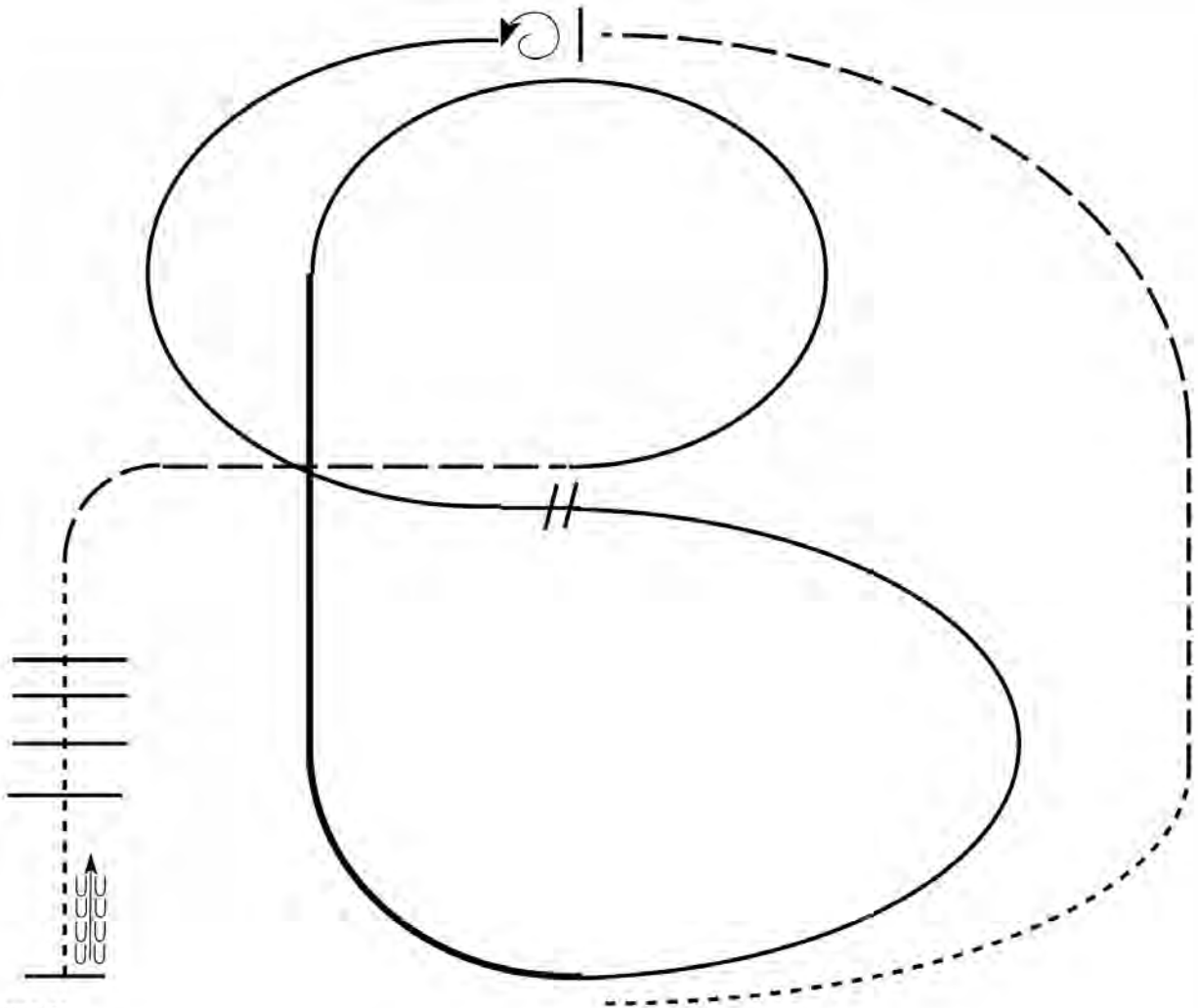

1. Walk
2. Trot
3. Extend the trot, at the top of the arena, stop
4. 360 degree turn to the left
5. Left lead 1/2 circle, lope to the center
6. Change leads (simple or flying)
7. Right lead 1/2 circle
8. Extended lope up the long side of arena (right lead)
9. Collect back to a lope around the top of the arena and back to center
10. Break down to an extended trot
11. Walk over poles.
12. Stop and back

Walk	-----
Jog	- - - - -
Extended Jog	-----
Lope	
Lead Change	///
Back	←
Marker	(B)

[RR/1]

Pattern Provided by:

*ApHCS*

# Saentis Color Show

## OKV Open Westernhorse

Show Date: 05-20-2017

www.HorseShowPatterns.com

www.HorseShowPatterns.com

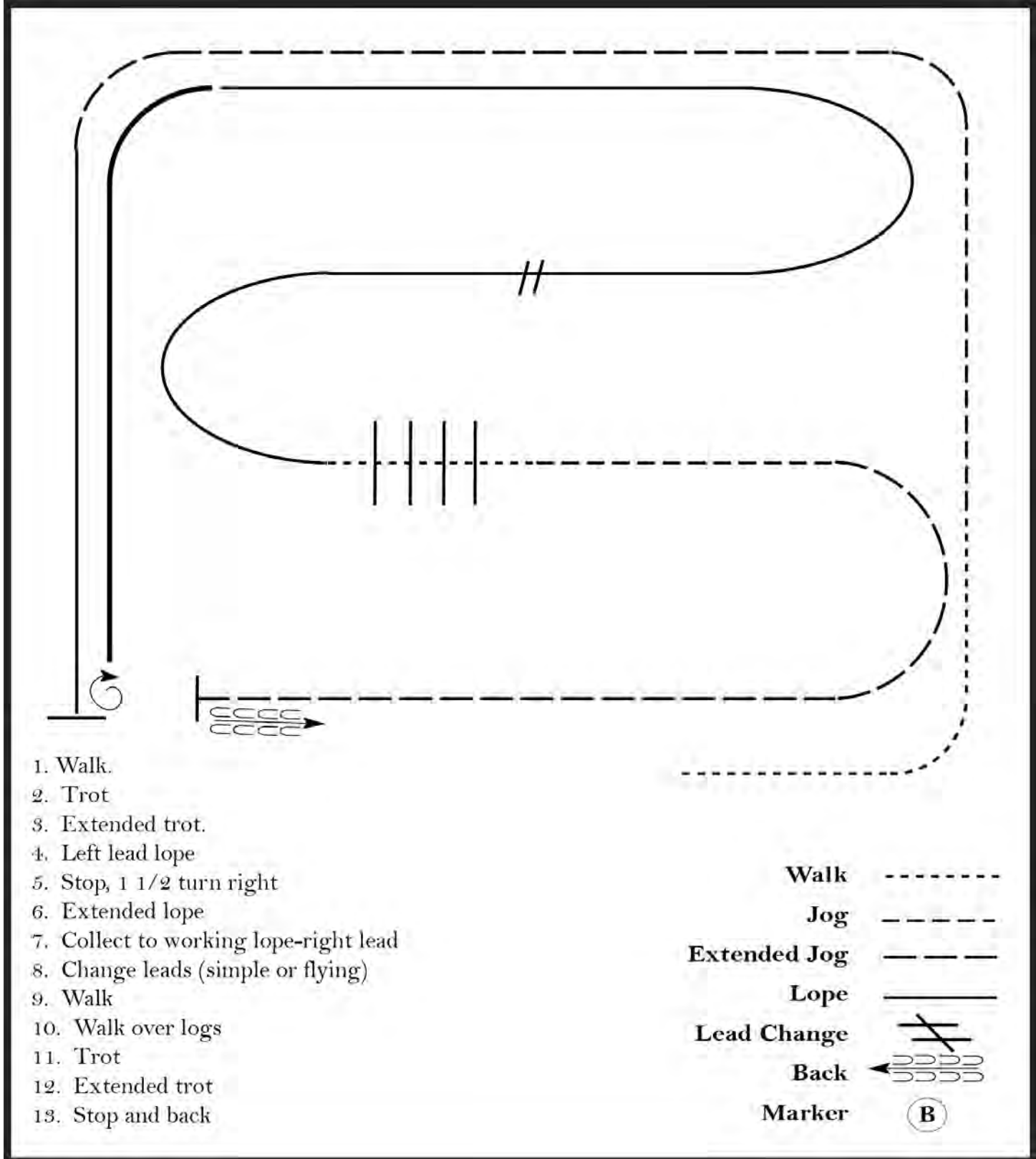

1. Walk
2. Trot
3. Extended trot.
4. Left lead lope
5. Stop, 1 1/2 turn right
6. Extended lope
7. Collect to working lope-right lead
8. Change leads (simple or flying)
9. Walk
10. Walk over logs
11. Trot
12. Extended trot
13. Stop and back

- |              |           |
|--------------|-----------|
| Walk         | -----     |
| Jog          | - - - - - |
| Extended Jog | -----     |
| Lope         | —————     |
| Lead Change  | //        |
| Back         | ←←←←←     |
| Marker       | (B)       |

[RR/2]

Pattern Provided by:

*ApHCS*

# Saentis Color Show

## Greenhorn Horsemanship

Show Date: 05-20-2017

w w w . H o r s e S h o w P a t t e r n s . c o m

w w w . H o r s e S h o w P a t t e r n s . c o m

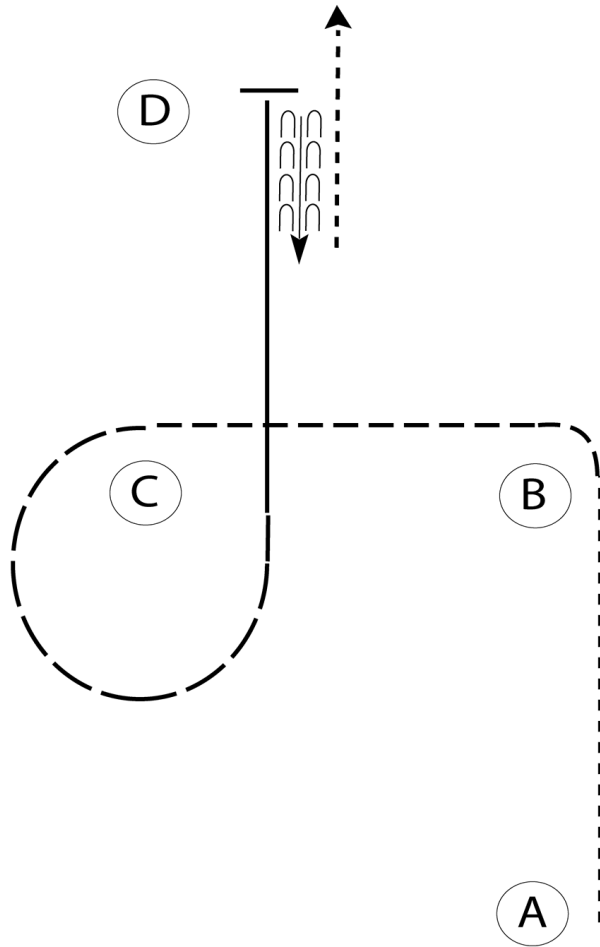

Be ready at A.

1. Walk to B.
2. Jog around B and to C.
3. Extended jog around C.
4. Lope on the left lead from C to D.
5. Stop at D and back approximately one horse length.
6. Walk out.

Follow the directions of your ring steward.

Walk	-----
Jog	- - - - -
Extended Jog	— — — —
Lope	————
Lead Change	↙
Back	←
Marker	⊙ B

[WH/1-78]

Pattern Provided by:

*ApHCS*

# Saentis Color Show

## Open Ranch Riding

Show Date: 05-20-2017

www.HorseShowPatterns.com

www.HorseShowPatterns.com

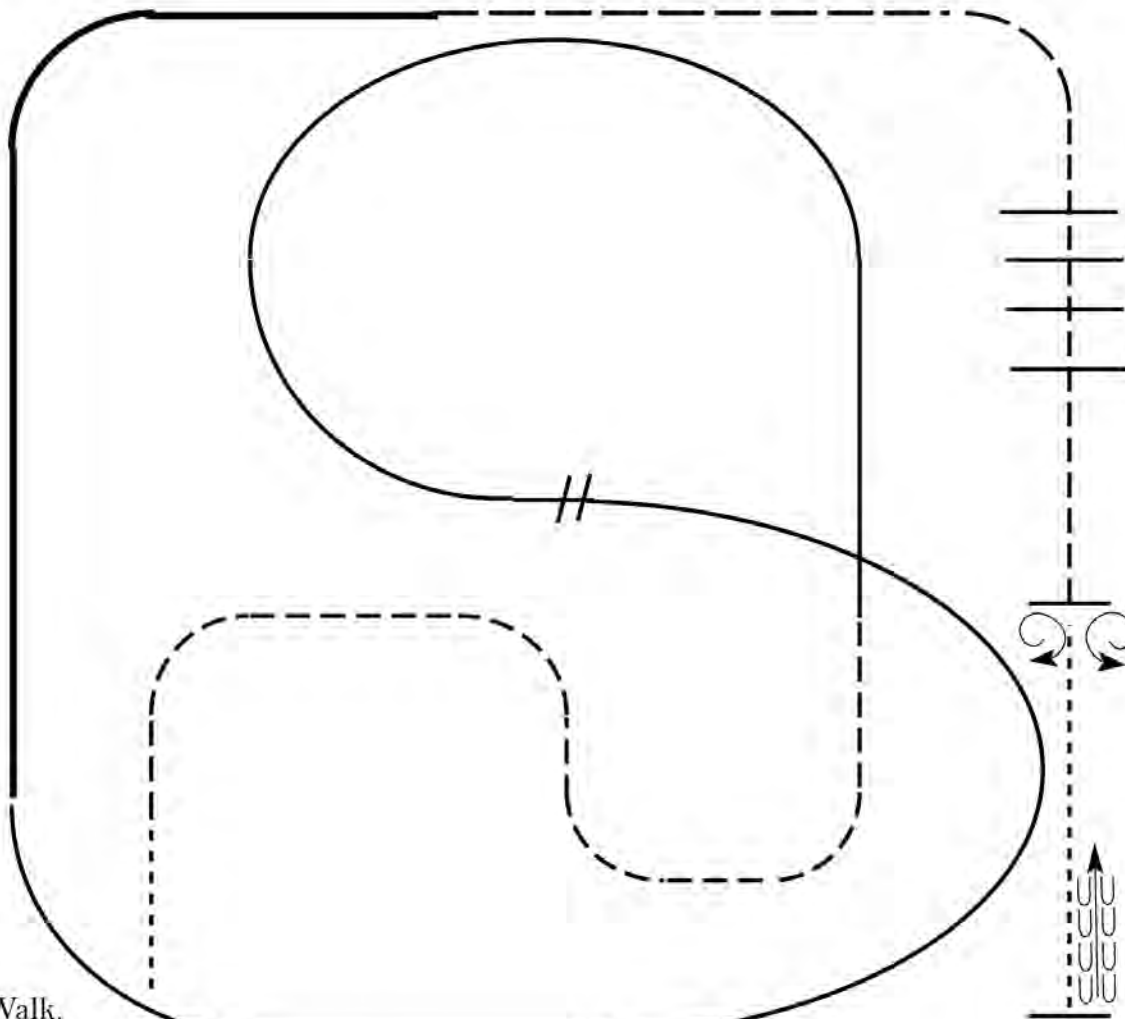

1. Walk.
2. Trot serpentine
3. Lope left lead around end of arena and then diagonally across arena.
4. Change leads (simple or flying) and
5. Lope on the right lead around end of the arena.
6. Extend lope on the straight away around corner to center of arena.
7. Extend trot around corner of arena
8. Collect to a trot
9. Trot over poles
10. Stop do a 360 turn each direction (either direction 1st)
11. Walk, stop and back.

Walk	-----
Jog	- - - - -
Extended Jog	-----
Lope	
Lead Change	//
Back	←←←←←
Marker	(B)

[RR/4]

Pattern Provided by:

*ApHCS*

# Saentis Color Show

## Greenhorn Reining

Show Date: 05-20-2017

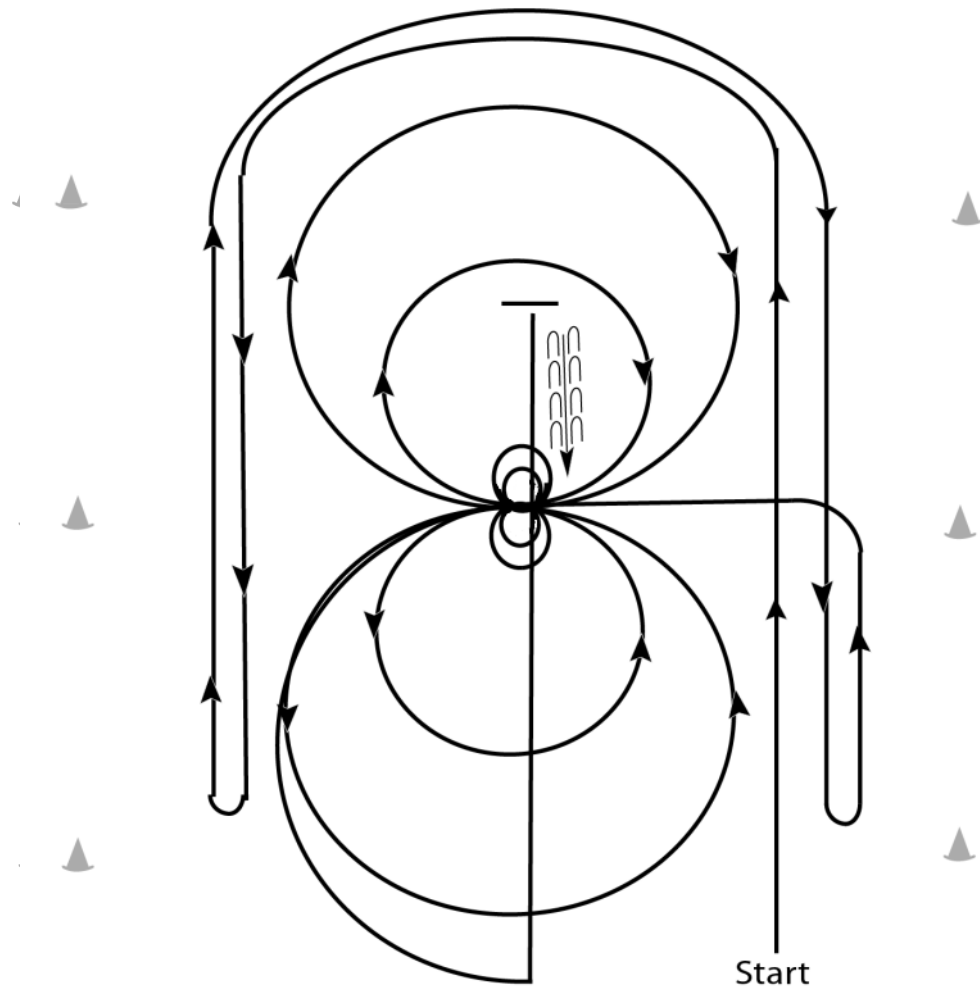

1. Beginning, lope straight up the right side of the arena, circle the top of the arena, run straight down the opposite or left side of the arena past the center mark and do a right rollback - no hesitation.
2. Continue straight up the left side of the arena circle back around the top of the arena run straight down the right side of the arena past the center marker and do a left rollback - no hesitation.
3. Continue up the right side of the arena to the center marker, at the center marker horse should be on the left lead and complete two circles to the left, one large fast and one small slow. Stop at center. Hesitate.
4. Complete **two** spins to the left. Hesitate.
5. Complete two circles to the right, one large fast and one small slow. Stop at center. Hesitate.
6. Complete **two** spins to the right. Hesitate.
7. Begin a large fast circle to the left, do not close this circle. Continue up the center of the arena past the center marker and do a sliding stop.
8. Back up at least ten feet. Hesitate to demonstrate completion of pattern.

[R/NRHAP-13A]

Pattern Provided by:

*ApHCS*

# Saentis Color Show

## Open Reining

Show Date: 05-20-2017

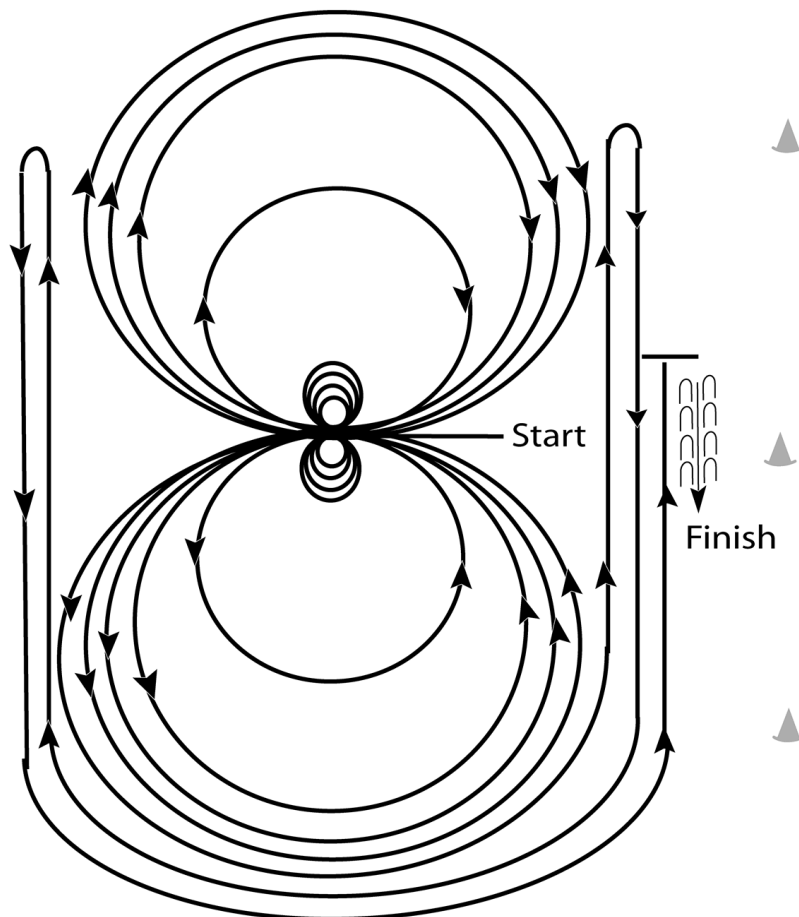

Horses may walk or trot to the center of the arena. Beginning at the center of the arena facing the left wall or fence.

1. Beginning on the left lead, complete three circles to the left: the first two circles large and fast; the third circle small and slow. Stop at the center of the arena.
  2. Complete four spins to the left. Hesitate.
  3. Beginning on the right lead, complete three circles to the right: the first two circles large and fast; the third circle small and slow. Stop at the center of the arena.
  4. Complete four spins to the right. Hesitate.
  5. Beginning on the left lead, run a large fast circle to the left, change leads at the center of the arena, run a large fast circle to the right, and change leads at the center of the arena.
  6. Continue around previous circle to the left but do not close this circle. Run up the right side of the arena past the center marker and do a right rollback at least twenty feet (6.09m) from the wall or fence – no hesitation.
  7. Continue around previous circle but do not close this circle. Run up the left side of the arena past the center marker and do a left rollback at least twenty feet (6.09m) from the wall or fence – no hesitation.
  8. Continue back around previous circle but do not close this circle. Run up the right side of the arena past the center marker and do a sliding stop at least twenty feet (6.09m) from the wall or fence. Back up at least ten feet (3m). Hesitate to demonstrate completion of the pattern.
- Rider may dismount and drop bridle to the designated judge.

[R/NRHAP-5]

Pattern Provided by:

*ApHCS*



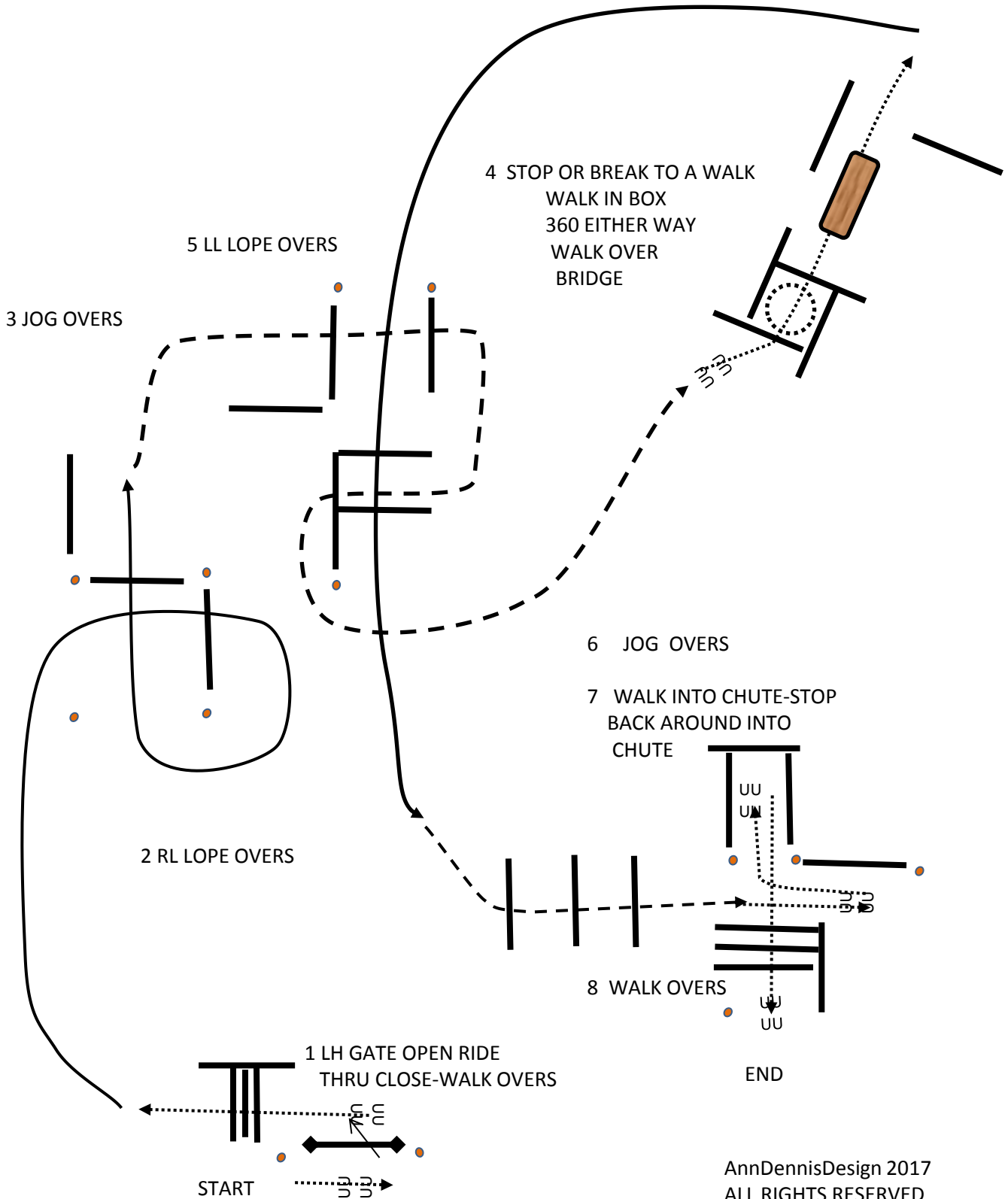

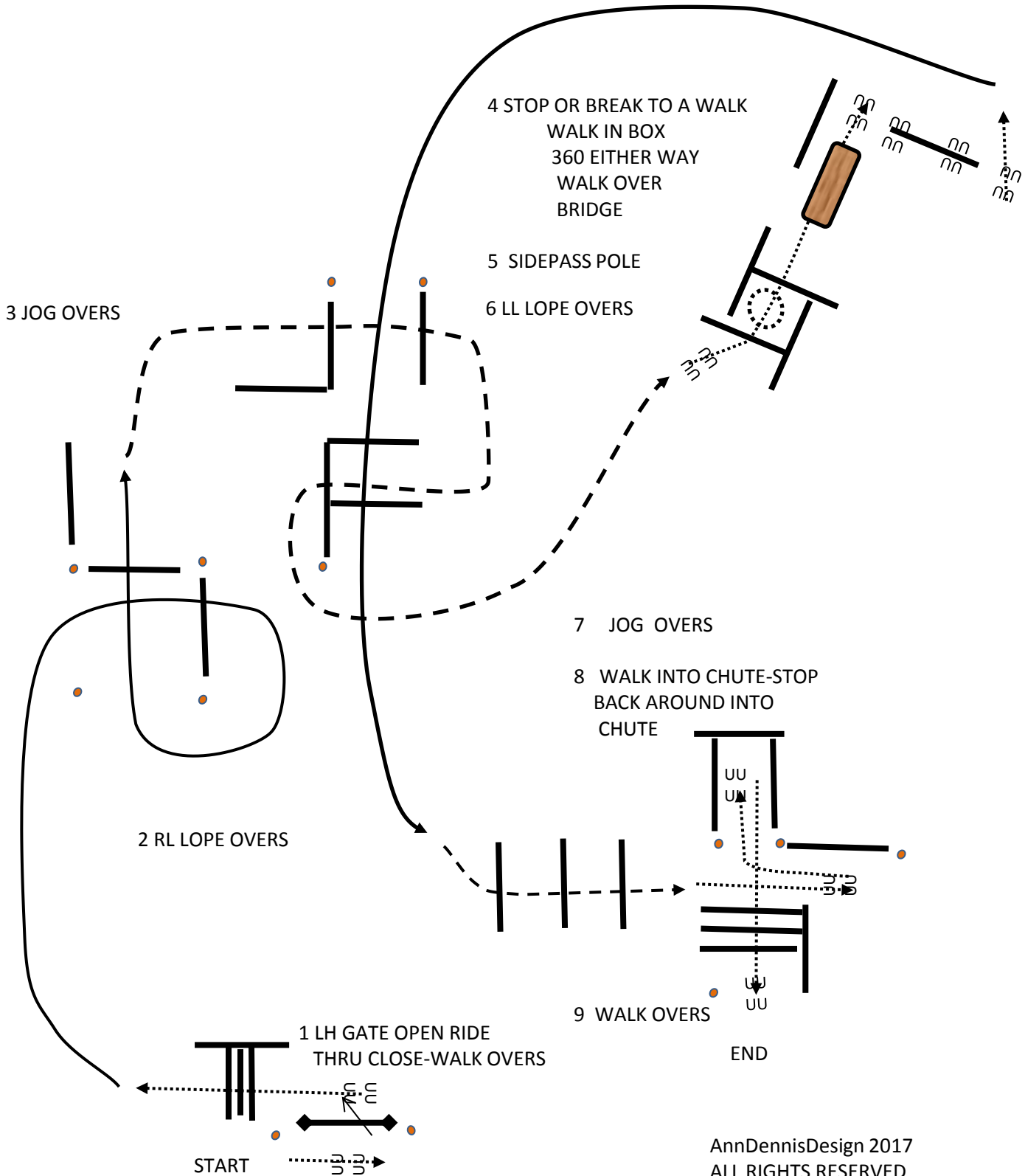

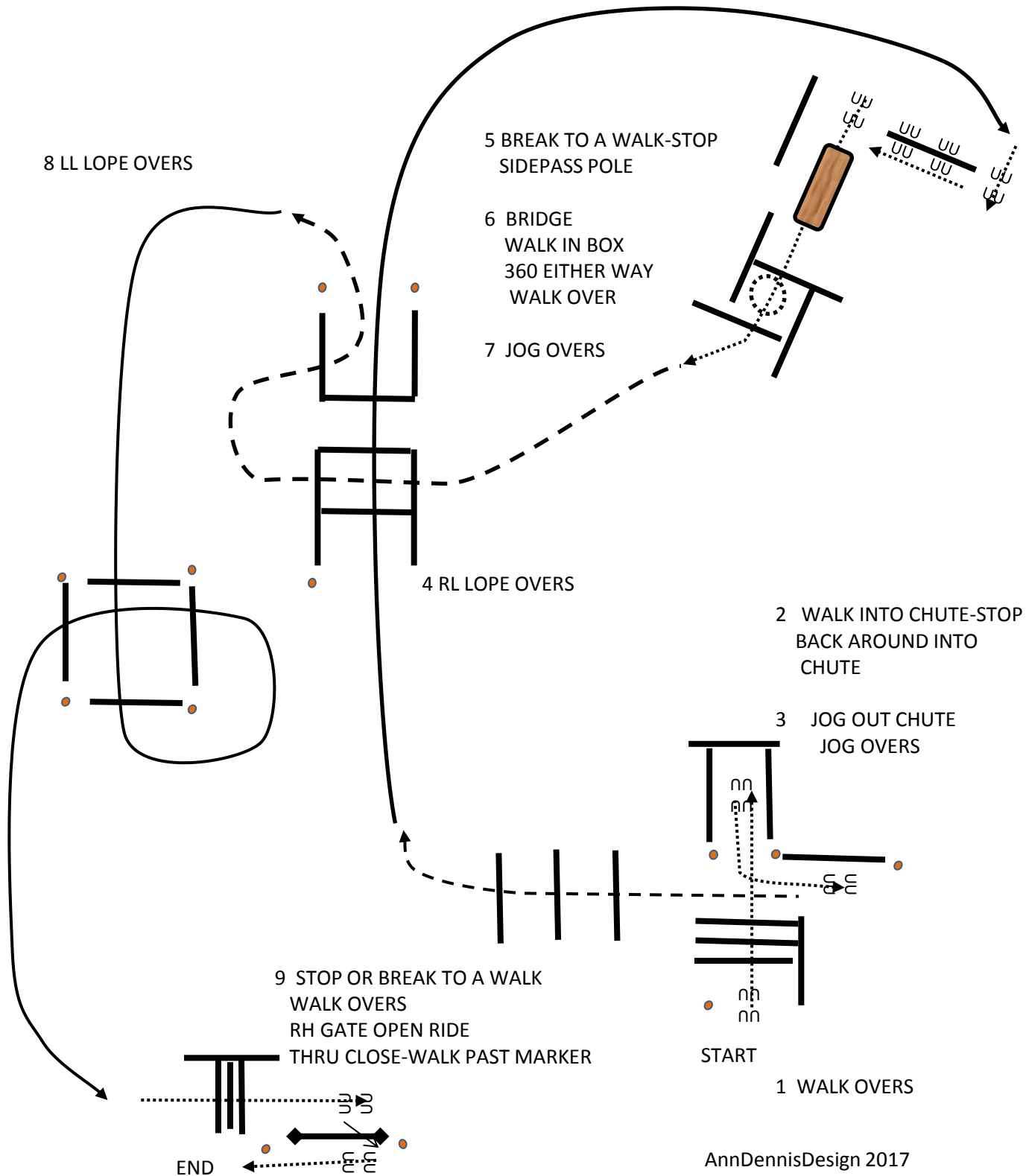

# Saentis Color Show

## Novice Amateur + Youth Hunt Seat Equitation

Show Date: 05-21-2017

www.HorseShowPatterns.com

www.HorseShowPatterns.com

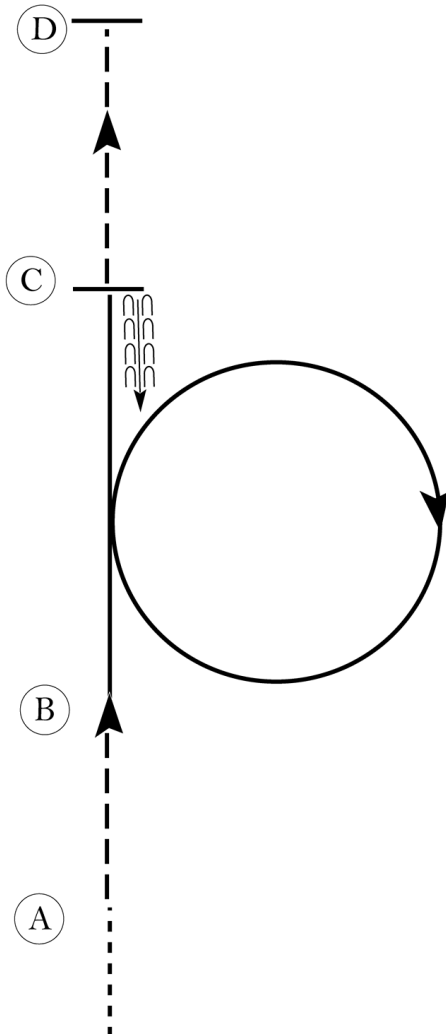

Be ready before A.

1. Walk to A.
2. Sitting trot from A to B.
3. Right lead canter at B. Circle to the right and continue to canter to C.
4. Stop at C and back one horse length.
5. Posting trot on the right diagonal to D.
6. Stop at D.

When dismissed, follow the instructions of your ring steward.

Walk	-----
Trot	- - - - -
Extended Trot	— — — — —
Canter	—————
Leg Yield	
Lead Change	— / —
Back	← ← ← ← ←
Marker	(B)
Sidepass	← — — — — ←
Hand Gallop	— — — — —

[HSE/2-35]

Pattern Provided by:

*ApHCS*

# Saentis Color Show

## ApHC Open Western Riding

Show Date: 05-21-2017

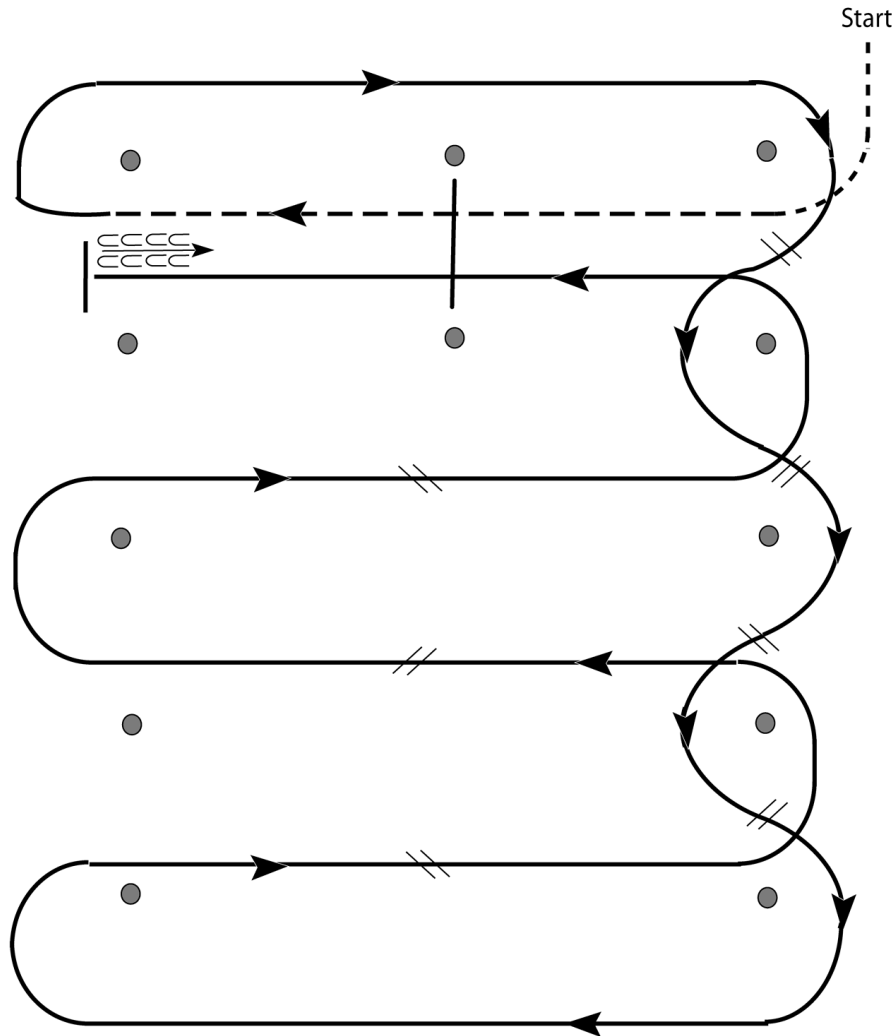

1. Walk, transition to jog, jog over log.
2. Transition to right.
3. First line change.
4. Second line change.
5. Third line change.
6. Fourth line change.
7. First crossing change.
8. Second crossing change.
9. Third crossing change.
10. Lope over log.
11. Lope, stop and back.

[WR/OP-4]

Pattern Provided by:

*ApHCS*

# Saentis Color Show

## Novice Amateur + Youth Horsemanship

Show Date: 05-21-2017

www.HorseShowPatterns.com

www.HorseShowPatterns.com

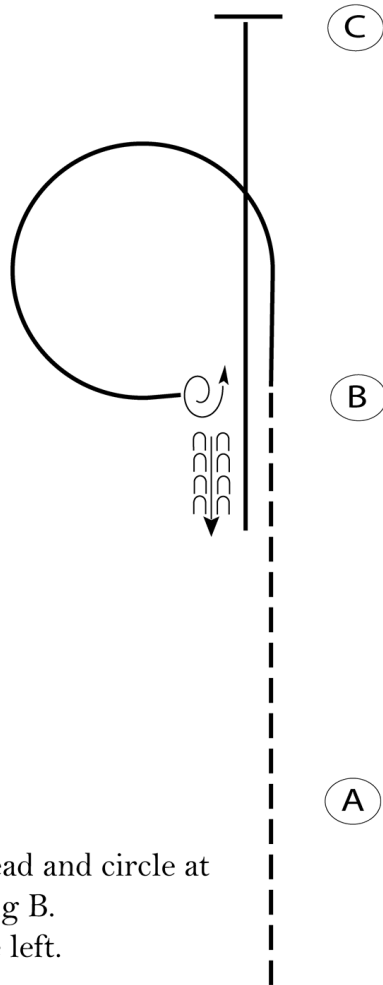

Begin before A at a jog.

1. Jog from A to B.
2. At B, lope on the left lead and circle at B as shown. Stop facing B.
3. Turn 1 1/4 turn to the left.
4. Back one horse length.
5. Lope on the right lead to C. Stop at C.

Follow the instructions of your ring steward.

Walk	-----
Jog	- - - - -
Extended Jog	- - - - -
Lope	—————
Leg Yield	
Lead Change	— / —
Back	← C C C C C C C C C C
Marker	⊙ B
Sidepass	←-----→

[WH/2-17]

Pattern Provided by:

*ApHCS*





# Saentis Color Show

## ApHC Open Reining

Show Date: 05-21-2017

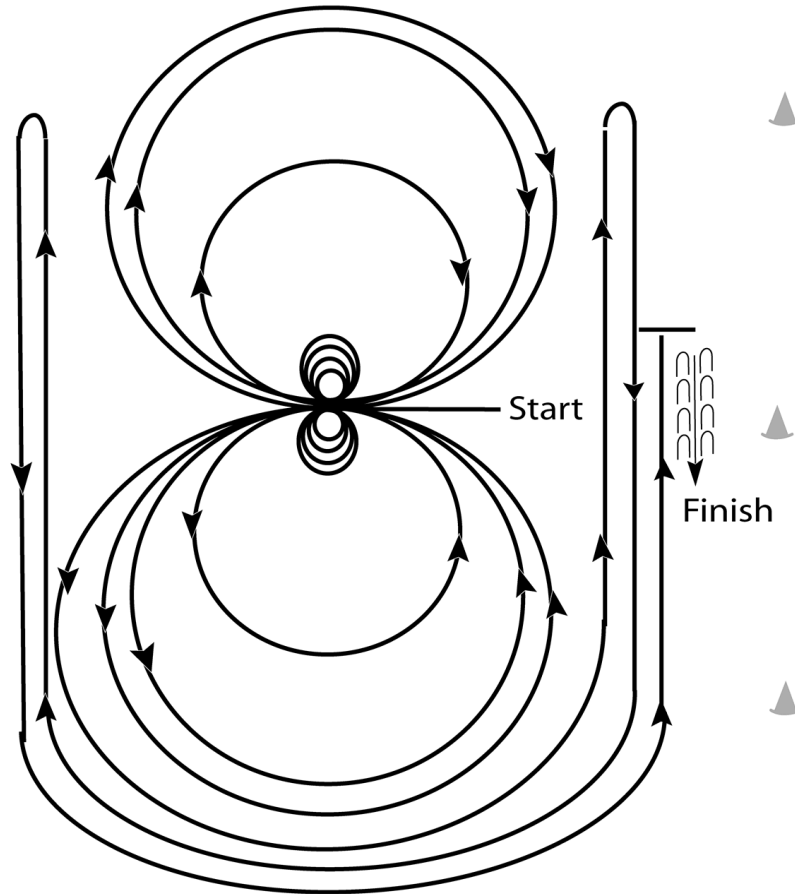

Horses may walk or trot to the center of the arena. Beginning at the center of the arena facing the left wall or fence.

1. Complete four spins to the right.
  2. Complete four spins to the left. Hesitate.
  3. Beginning on the left lead, complete three circles to the left: the first two circles large and fast; the third circle small and slow. Change leads at the center of the arena.
  4. Complete three circles to the right: the first two circles large and fast; the third circle small and slow. Change leads at the center of the arena.
  5. Begin a large, fast circle to the left but do not close this circle. Run up the right side of the arena past the center marker and do a right rollback at least twenty feet (6.09m) from the wall or fence – no hesitation.
  6. Continue back around previous circle but do not close this circle. Run up the left side of the arena past the center marker and do a left rollback at least twenty feet (6.09m) from the wall or fence – no hesitation.
  7. Continue back around previous circle but do not close this circle. Run up the right side of the arena past the center marker and do a sliding stop at least twenty feet (6.09m) from the wall or fence. Back up at least ten feet (3m). Hesitate to demonstrate the completion of the pattern.
- Rider may dismount and drop bridle to the designated judge.

[R/NRHAP-6]

Pattern Provided by:

*ApHCS*