

Patterns

Appaloosa Turnier

Samstag,
13. Juni 2015

Reithalle KRVA
Aarau, Schachen



APPALOSA
switzerland HORSE
CLUB

www.appaloosa.ch

Greenhorn Showmanship at Halter

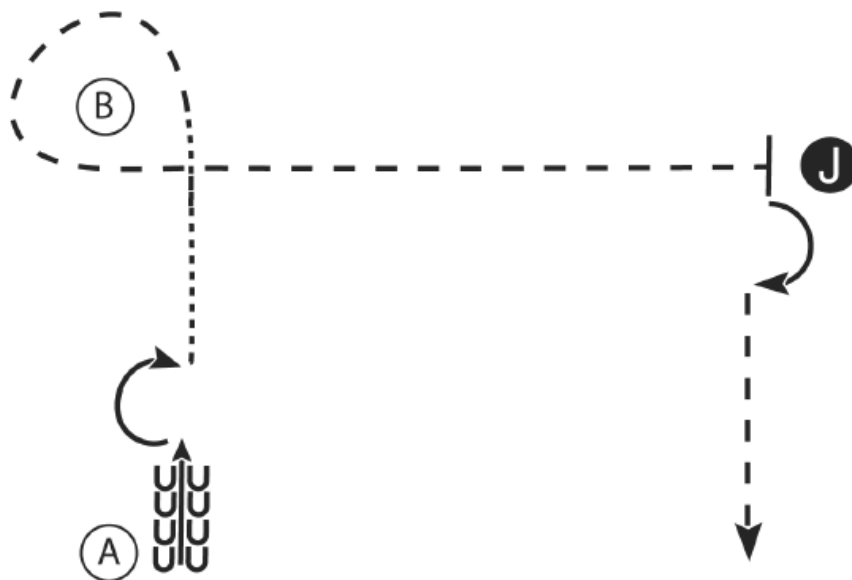

1. At A back 4 steps
2. Perform a 180 degree turn
3. Walk to B
4. At B trot around B and to the judge, set up for inspection
5. When dismissed perform a 90 degree turn and trot straight away from the judge

Walk
Trot	-----
Back	← ↔↔↔↔ ↔↔↔↔
Marker	(B)
Judge	(J)

Open In-Hand Trail

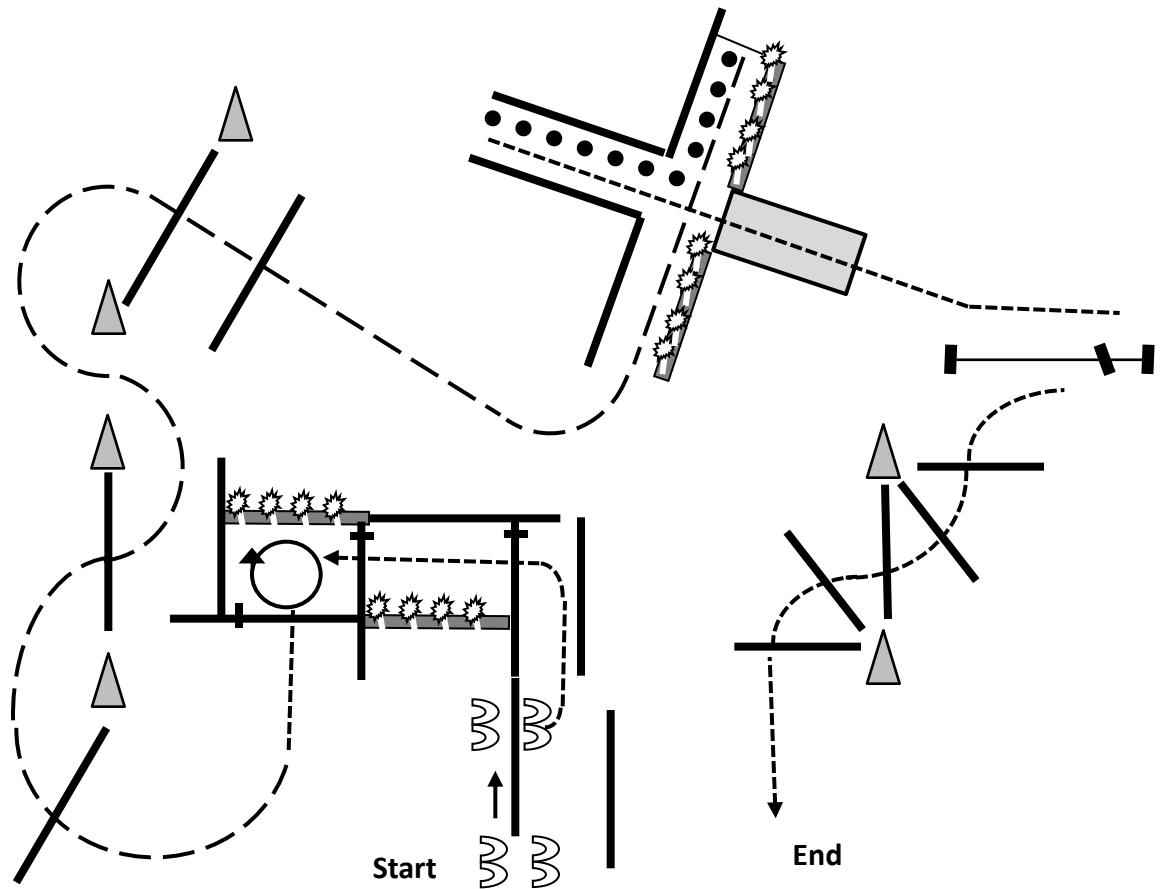

.....	Walk	● ● ●	Back Up	Ⓐ	Marker
- - -	Jog / Trot	⤿	Turn	ⓙ	Judge
— — —	Lope / Canter	⤿	Side-pass	🌸	Flowers
	Stop	△	Cone	🌱	Plants

1. Side-pass left
2. Walk into chute, walk over elevated poles and into box, turn 270° right and walk out
3. Jog over pole and into chute
4. Back up "L"
5. Walk over bridge
6. Walk to gate (rope), open rope, walk over pole and close rope
7. Walk over poles

ApHC Open Green Trail

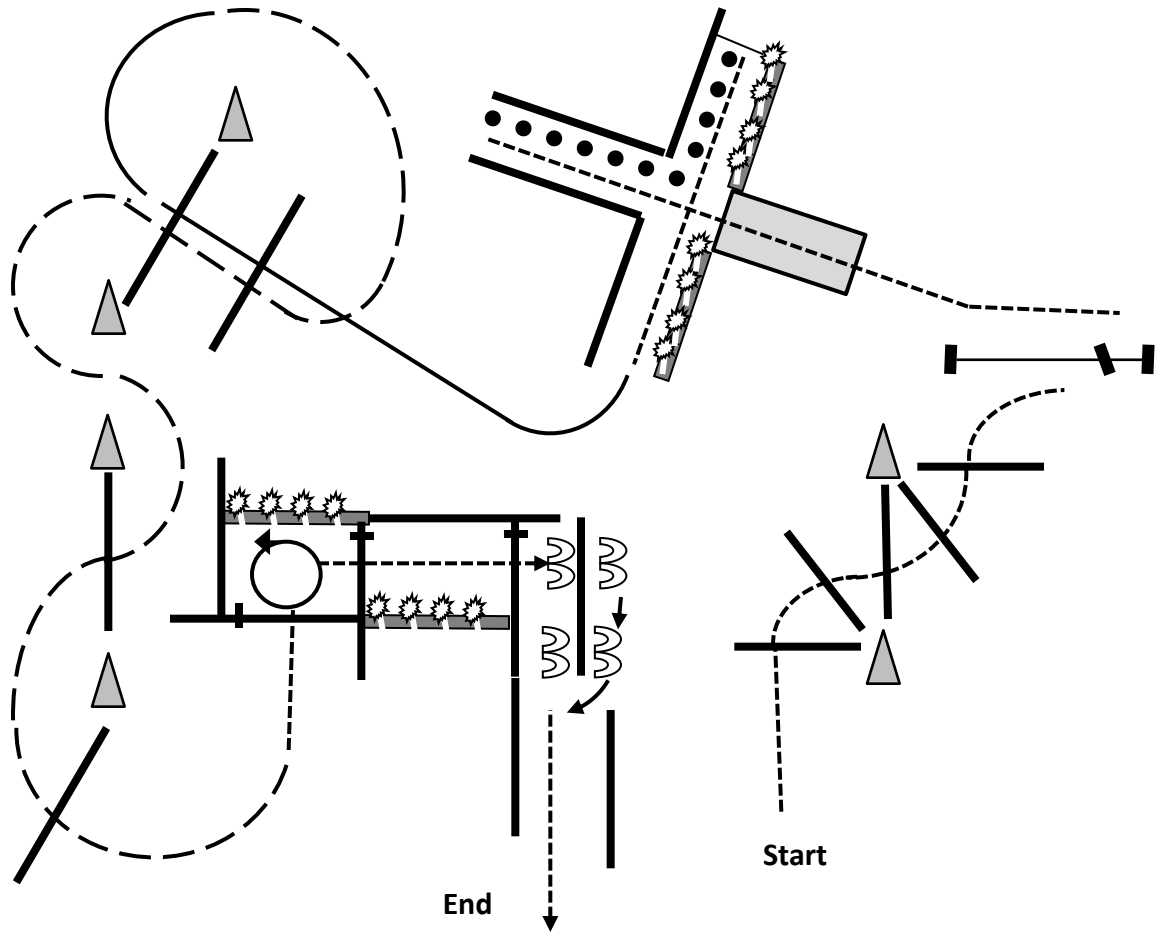

.....	Walk	● ● ●	Back Up	Ⓐ	Marker
- - -	Jog / Trot	↶	Turn	ⓙ	Judge
— — —	Lope / Canter	↶↶↶	Side-pass	🌸	Flowers
	Stop	△	Cone	🌿	Plants

1. Walk over poles
2. Walk to gate (rope), open rope, walk over pole and close rope
3. Walk over bridge and into chute
4. Back up "L" and walk out of chute
5. Lope over (right lead)
6. Jog over
7. Walk into box (elevated pole), turn 270° left and walk over elevated poles
8. Side-pass right, bring front legs thru gap and walk out of chute

Greenhorn Trail, Greenhorse Trail

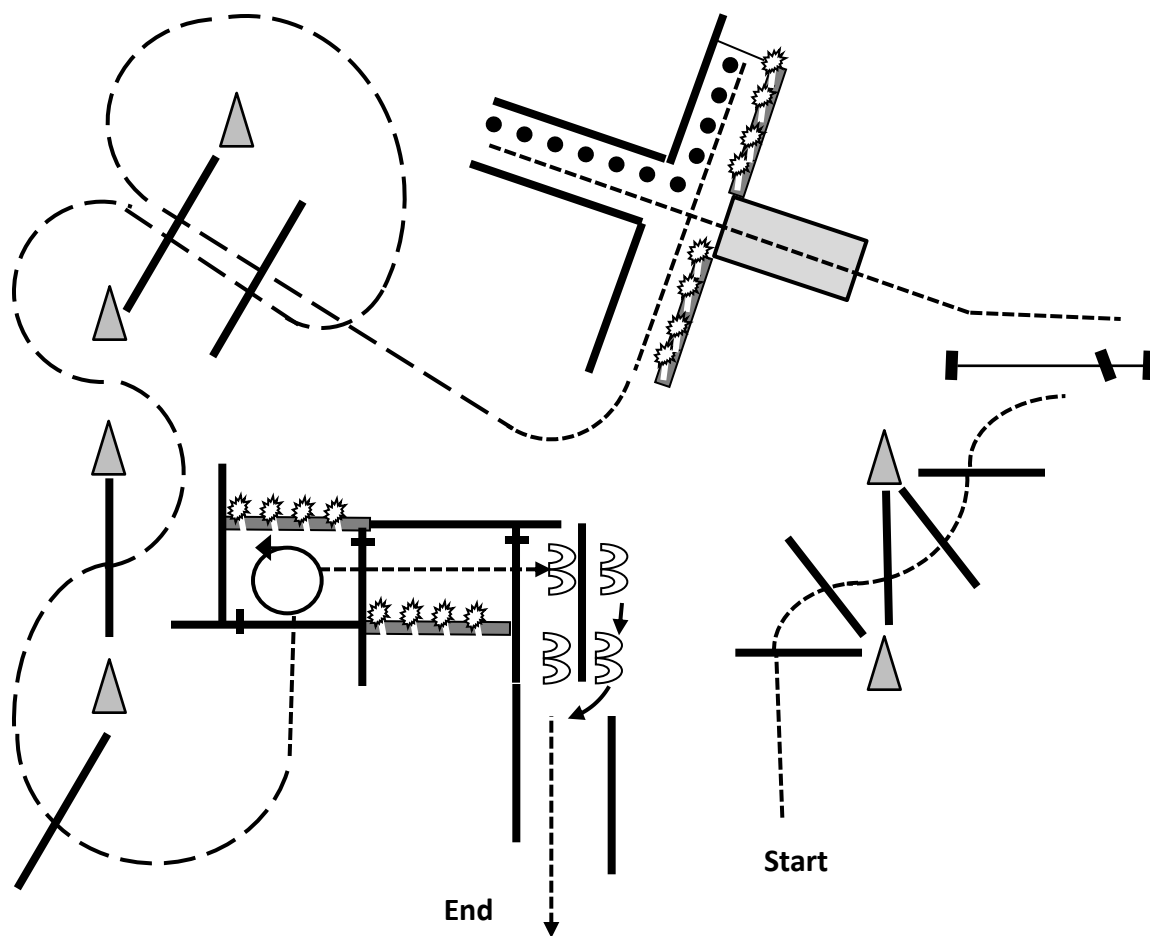

.....	Walk	● ● ●	Back Up	Ⓐ	Marker
- - -	Jog / Trot	⤿	Turn	ⓙ	Judge
—	Lope / Canter	⤿	Side-pass	🌸	Flowers
	Stop	△	Cone	🌿	Plants

1. Walk over poles
2. Walk to gate (rope), open rope, walk over pole and close rope
3. Walk over bridge and into chute
4. Back up "L" and walk out of chute
5. Jog over
6. Walk into box (elevated pole), turn 270° left and walk over elevated poles
7. Side-pass right, bring front legs thru gap and walk out of chute

ApHC Open Trail

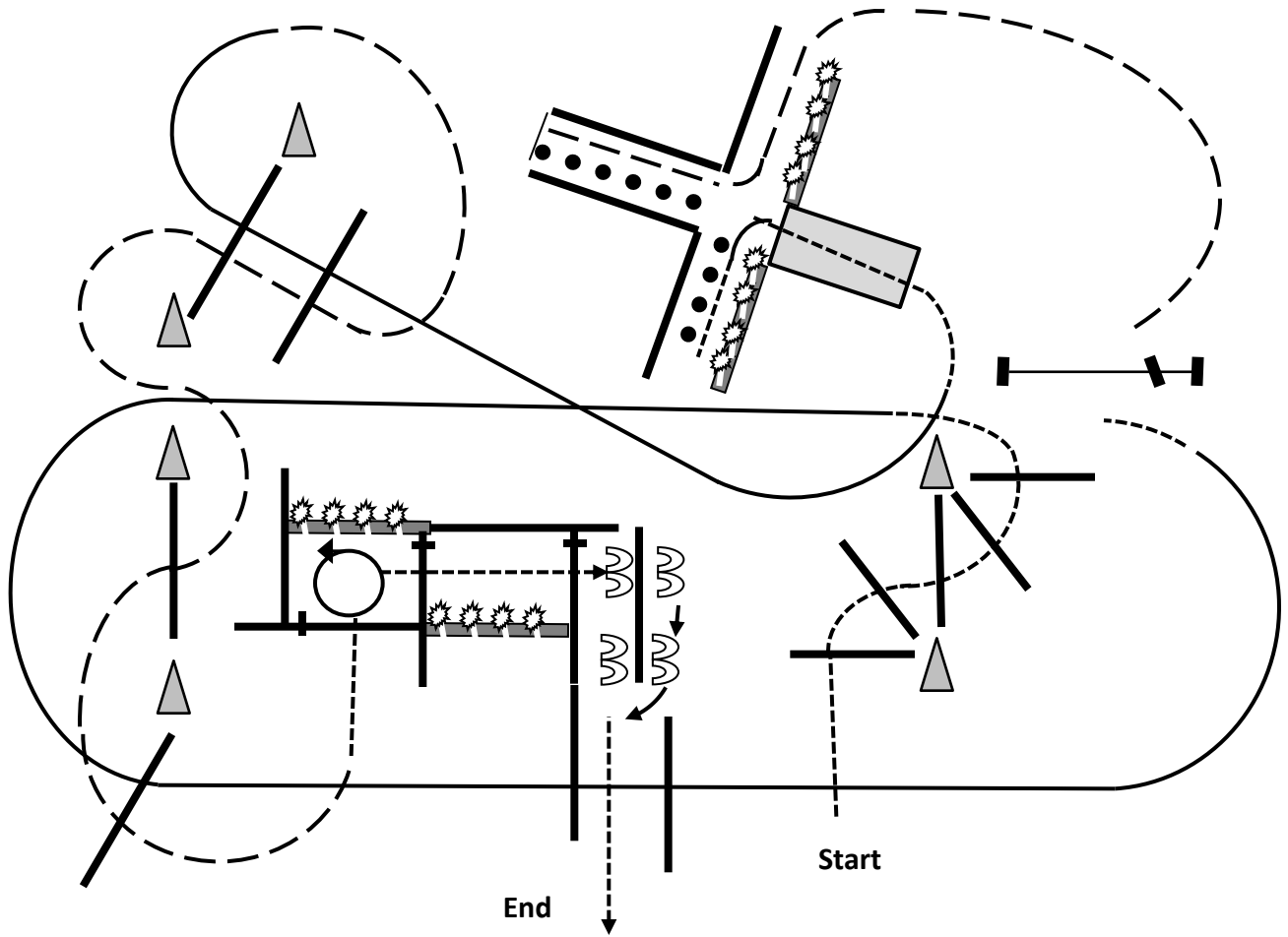

.....	Walk	● ● ●	Back Up	Ⓐ	Marker
- - -	Jog / Trot	↶	Turn	ⓙ	Judge
—	Lope / Canter	↶↷	Side-pass	🌸	Flowers
	Stop	△	Cone	🌿	Plants

1. Walk over poles
2. Lope over (left lead) break to a walk
3. Walk to gate (rope), open rope, back thru and close rope
4. Jog into chute and around 90° corner, then back up "L"
5. Walk over bridge
6. Lope over (right lead)
7. Jog over
8. Walk into box (elevated pole), turn 270° left and walk over elevated poles
9. Side-pass right, bring front legs thru gap and walk out of chute

Open Horse & Dog Trail

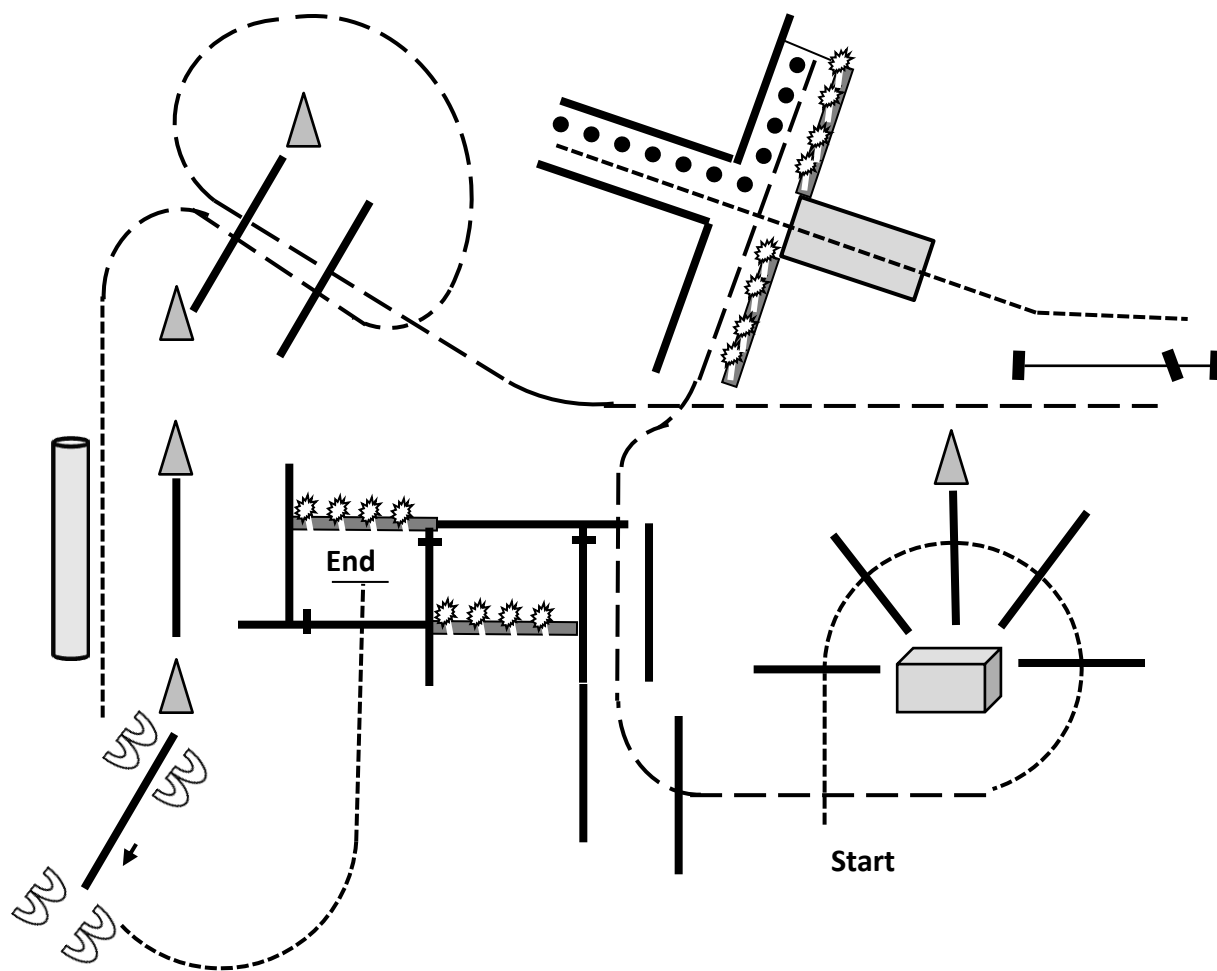

.....	Walk	● ● ●	Back Up	Ⓐ	Marker
- - -	Jog / Trot	⤿	Turn	ⓙ	Judge
—	Lope / Canter	⤿⤿	Side-pass	🌻	Flowers
	Stop	△	Cone	🌻	Plants

1. Remove leash at start; ask dog to lay down on hay ball, then walk over poles; dog should stay on hay ball until horse walked over the last pole
2. Ask dog to follow (either right or left side of the horse); jog over poles and into chute; stop
3. Ask dog to lay down; back up "L"
4. Walk over bridge; ask dog to follow behind horse over bridge
5. Ask dog to sit open gate (=rope) right hand, walk over elevated pole, ask dog to follow thru gate and to sit again, then close rope.
6. Ask dog to follow either side; jog over poles
7. Break to a walk; ask dog to pass the tunnel.
8. Ask dog to lay down; side-pass right all the way out
9. Walk into box; ask your dog to make a full circle around the horse; then get down off the horse; attach leash and walk out of the arena leading horse and dog by foot

Greenhorn Western Horsemanship

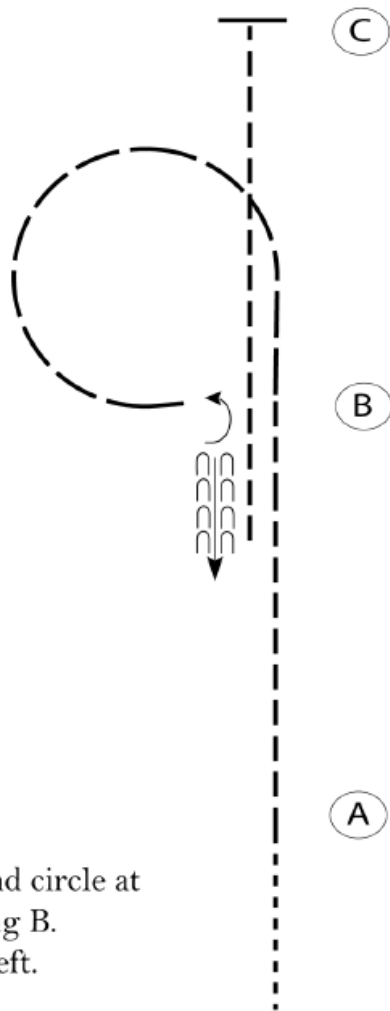

Begin before A at a walk.

1. Jog from A to B.
2. At B, extend the jog and circle at B as shown. Stop facing B.
3. Turn 1/4 turn to the left.
4. Back one horse length.
5. Jog to C. Stop at C.

Follow the instructions of your ring steward.

Walk	-----
Jog	-----
Extended Jog	-----
Lope	—————
Leg Yield	
Lead Change	— / —
Back	← — — — — —
Marker	⊙ (B)
Sidepass	← — — — — — →

PATTERN

5

1. Walk, transition to jog, jog over log.
2. Transition to the lope, on the left lead.
3. First line change.
4. Second line change.
5. Third line change.
6. Fourth line change.
7. First crossing change.
8. Lope over log.
9. Second crossing change.
10. Third crossing change.
11. Fourth crossing change.
12. Lope, stop and back.

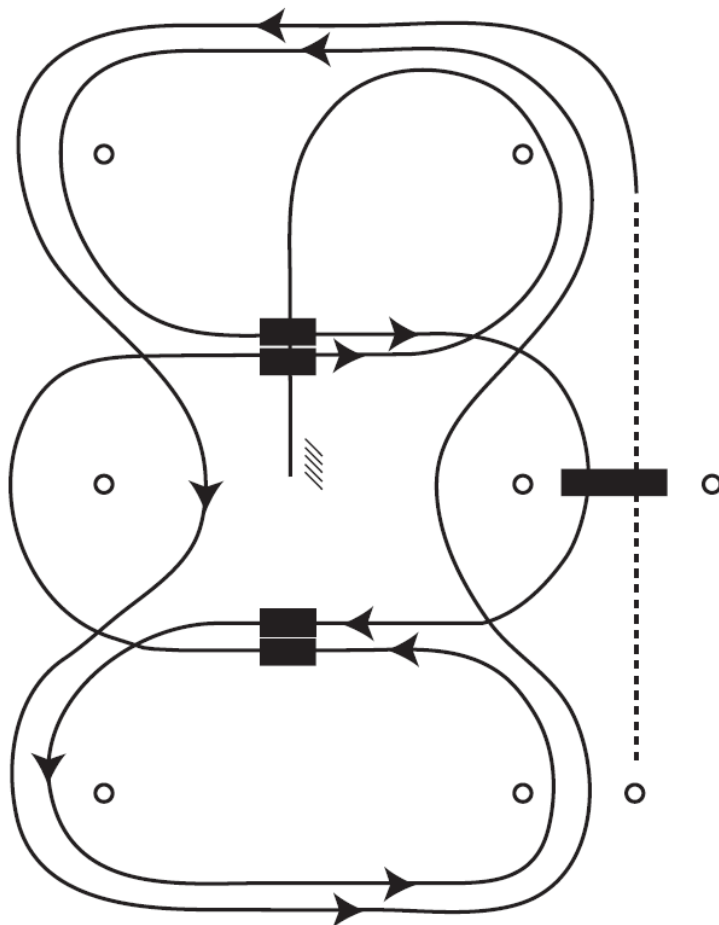

- | | | | |
|------|---------|---|---------------------------|
| WALK | | ○ | MARKER |
| JOG | - - - - | ■ | RECOMMENDED CHANGING AREA |
| LOPE | ———— | ▭ | LOG |
| BACK | /////// | | |

Greenhorn/Greenhorse Ranch Horse Pleasure

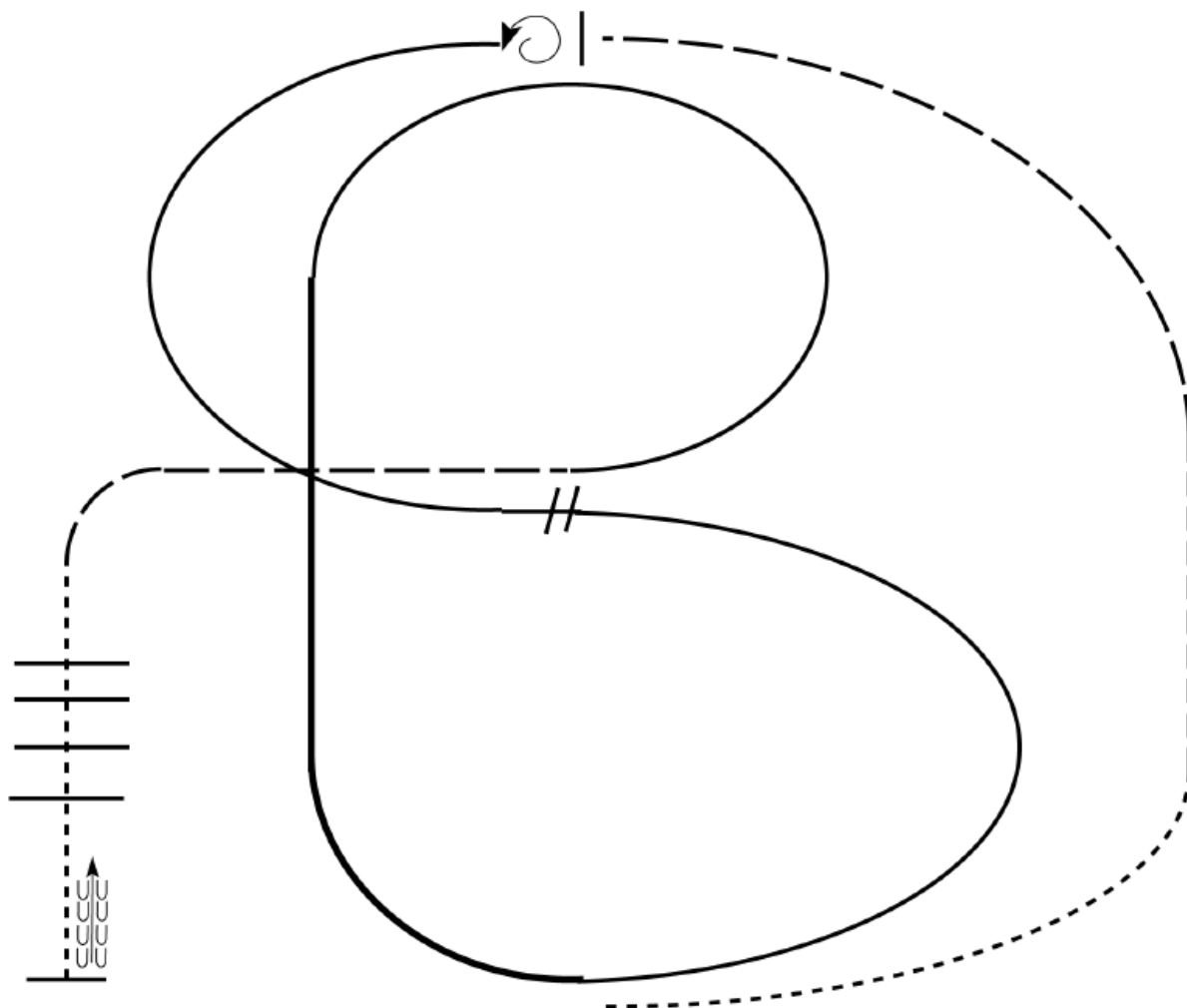

1. Walk
2. Trot
3. Extend the trot, at the top of the arena, stop
4. 360 degree turn to the left
5. Left lead 1/2 circle, lope to the center
6. Change leads (simple or flying)
7. Right lead 1/2 circle
8. Extended lope up the long side of arena (right lead)
9. Collect back to a lope around the top of the arena and back to center
10. Break down to an extended trot
11. Walk over poles.
12. Stop and back

Walk	-----
Jog	- - - - -
Extended Jog	- - - - -
Lope	—————
Lead Change	
Back	
Marker	Ⓚ

ApHC Ranch Horse Pleasure

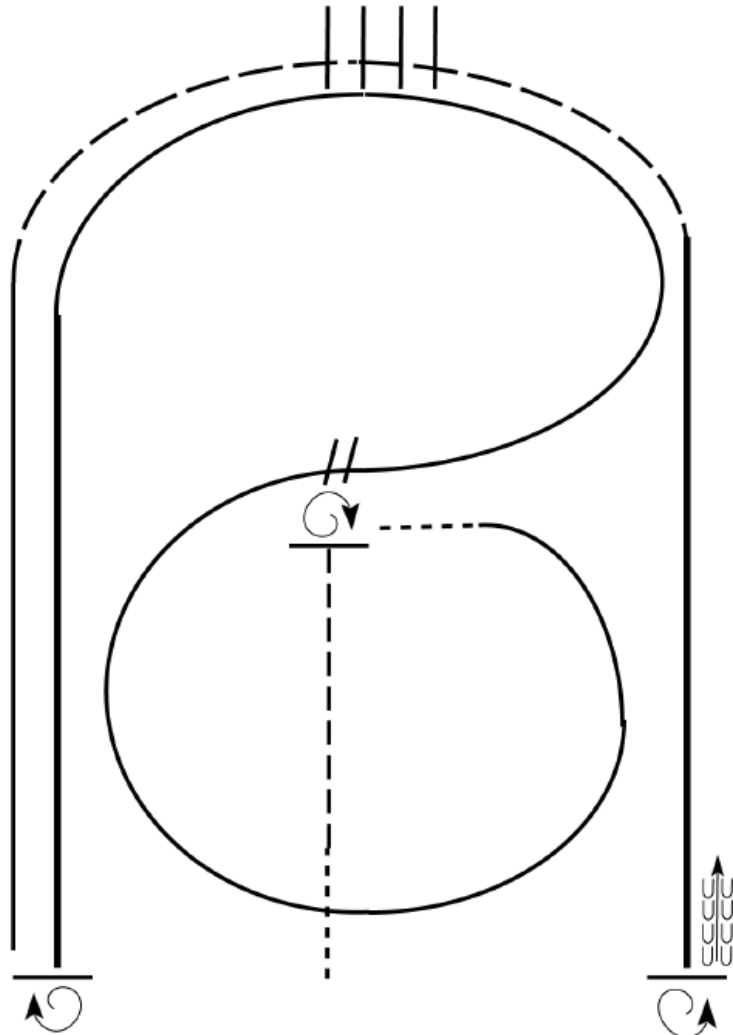

1. Walk
2. Jog
3. Stop, do a 1 1/4 turn to the right
4. Walk. Then, lope small circle on the right lead
5. Change leads, (simple or flying) lope left lead around end of the arena
6. Extend the lope on the left lead
7. Stop, do a 2 1/2 turns right
8. Lope straight on the right lead
9. Extend the jog around end of the arena across poles/logs
10. Extend the lope on right lead
11. Stop, do 2 turns left
12. Back

Walk	-----
Jog	-----
Extended Jog	-----
Lope	-----
Lead Change	
Back	
Marker	(B)

PATTERN

8a

Die Pferde dürfen im Schritt oder Trab zum Mittelpunkt der Arena gehen. Sie müssen vor Beginn des Patterns in der Mitte der Bahn, mit Blickrichtung auf die linke Bande stehen bleiben.

1. Zwei Spins nach links; Verharren;
2. Zwei Spins nach rechts; Verharren;
3. Drei vollständige Zirkel im Rechtsgalopp nach rechts, der erste Zirkel groß und schnell, der zweite Zirkel klein und langsam, der dritte Zirkel groß und schnell; Galoppwechsel (einfach oder fliegend) im Mittelpunkt der Bahn;
4. Drei vollständige Zirkel nach links, der erste Zirkel groß und schnell, der zweite Zirkel klein und langsam, der dritte Zirkel groß und schnell; Galoppwechsel (einfach oder fliegend) im Mittelpunkt der Bahn;
5. Weiter mit einem großen schnellen Zirkel auf der rechten Hand, der nicht geschlossen wird; Galopp an der rechten Seite der Bahn entlang bis hinter den Mittelmarker; Rollback nach links, zumindest sechs Meter von der Bande entfernt; Kein Verharren;
6. Weiter auf dem vorherigen Zirkel, jetzt auf der linken Hand; Der Zirkel wird nicht geschlossen; Galopp an der linken Seite der Bahn entlang bis hinter den Mittelmarker; Rollback nach rechts, zumindest sechs Meter von der Bande entfernt; Kein Verharren;
7. Weiter auf dem vorherigen Zirkel, jetzt wieder auf der rechten Hand; Der Zirkel wird nicht geschlossen; Galopp entlang der rechten Seite der Bahn bis hinter den Mittelmarker, Stop, zumindest sechs Meter von der Bande entfernt; Rückwärtsrichten von zumindest drei Metern Länge; Verharren, um das Ende der Prüfung anzuzeigen.

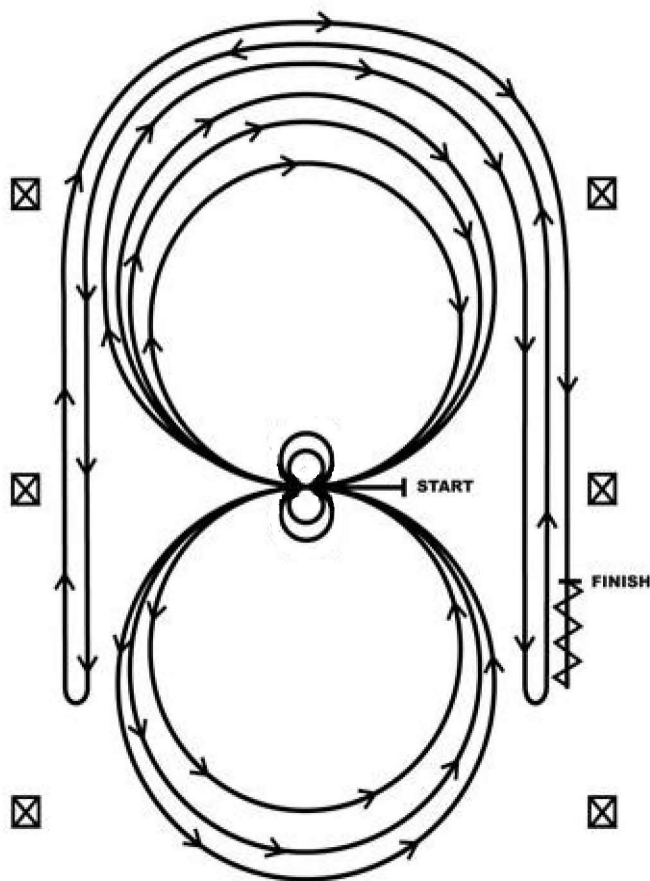

PATTERN

5

Horses may walk or trot to the center of arena. Horses must walk or stop prior to starting pattern. Beginning at the center of the arena facing the left wall or fence.

1. Beginning on the left lead, complete three circles to the left: the first two circles large and fast; the third circle small and slow. Stop at the center of the arena. Hesitate.
2. Complete four spins to the left. Hesitate.
3. Beginning on the right lead, complete three circles to the right: the first two circles large and fast; the third circle small and slow. Stop at the center of the arena. Hesitate.
4. Complete four spins to the right. Hesitate.
5. Beginning on the left lead, run a large fast circle to the left, change leads at the center of the arena, run a large fast circle to the right, and change leads at the center of the arena. (Figure 8)
6. Continue around previous circle to the left but do not close this circle. Run up the right side of the arena past the center marker and do a right rollback at least twenty feet (six meters) from the wall or fence – no hesitation.
7. Continue around previous circle but do not close this circle. Run up the left side of the arena past the center marker and do a left rollback at least twenty feet (six meters) from the wall or fence – no hesitation.
8. Continue back around previous circle but do not close this circle. Run up the right side of the arena past the center marker and do a sliding stop at least twenty feet (six meters) from the wall or fence. Back up at least ten feet (three meters). Hesitate to demonstrate completion of the pattern.

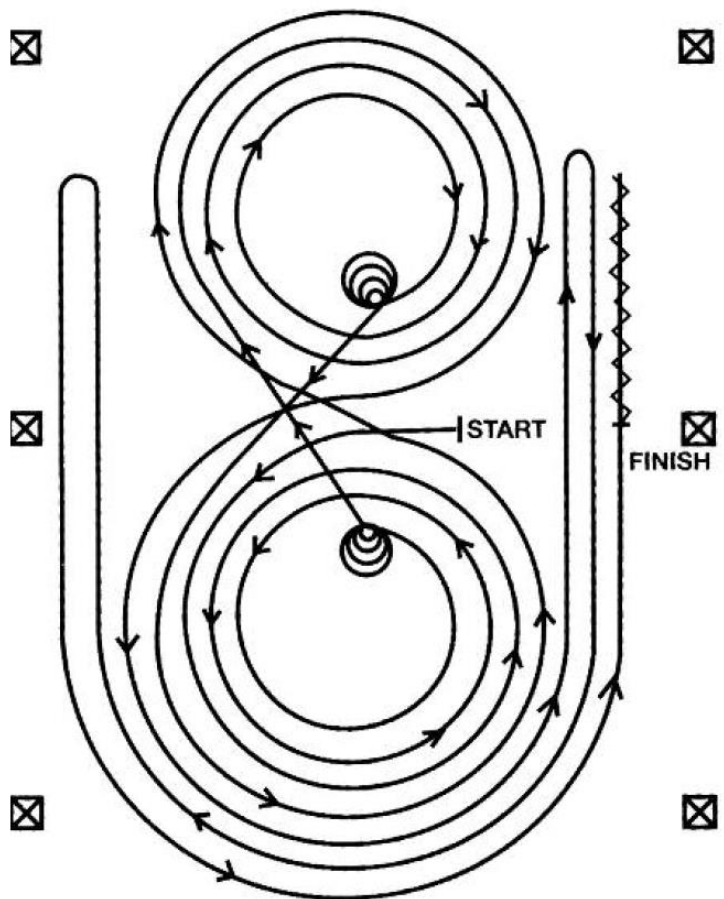

Rider must dismount and drop bridle to the designated judge.